

TARKA108 / KTARKA108

PORTATARGA REGOLABILE / ADJUSTABLE LICENSE PLATE BRACKETS

KAWASAKI ER-6N (09-11)

 LightTech
Lightech s.r.l.

31025 - Santa Lucia di Piave (TV) Italy
Tel. 0438 / 453010 - Fax 0438 / 655919
e.mail: info@lightech.it - web: www.lightech.it

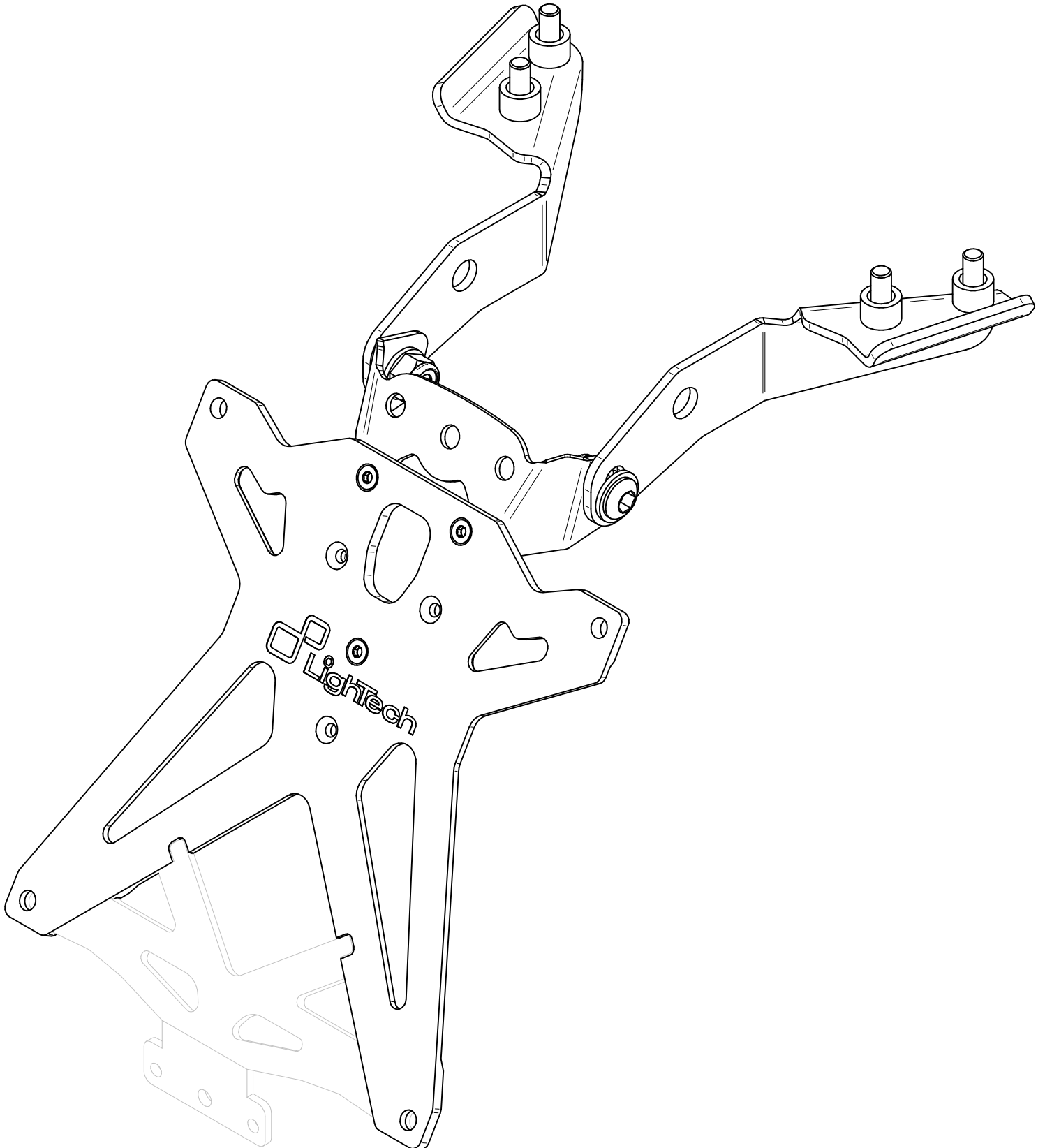



PIATTO/PLATE/PLATE/PLAQUE -- (1pz)



STAFFA/BACKET/BRACKET/SUPPORT -- (1pz)



VITE/SCREW/SCHRAUB/VIS -- M4x15 UNI5933 (3pz)



DADO AUTOBL./SELF-LOCKING NUT/SELBSTSICHERNDE MUTTER/ECROU AUTO-BLOQUANT -- M4 (3pz)

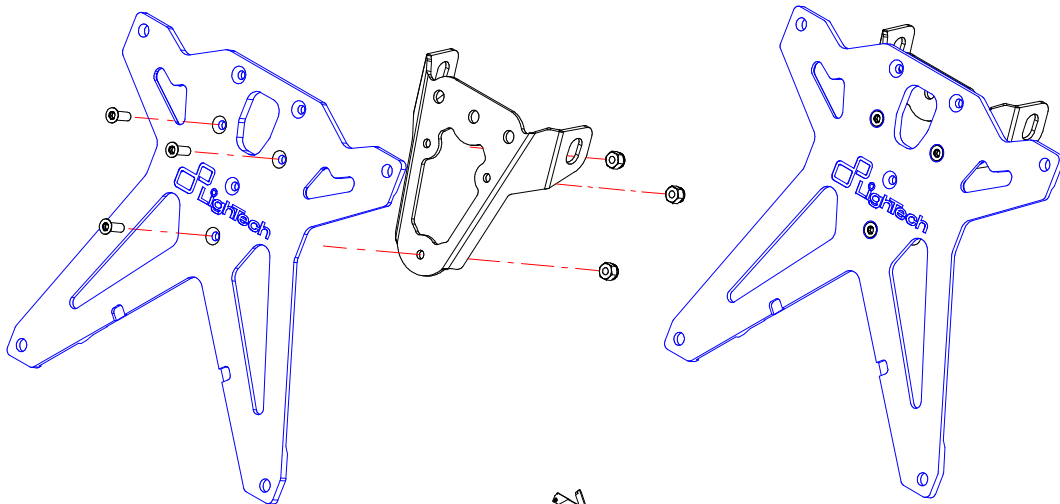

STAFFA/BACKET/BRACKET/SUPPORT -- (1pz)



LUCE TARGA/LICENSE PLATE LIGHT -- (1pz)



DISTANZIALE/SPACER/SPACER/ENTRETOISE -- (2pz)



VITE/SCREW/SCHRAUB/VIS -- M5x15 ISO7380 (2pz)



CATADIOTTRO -- (1pz)



RONDELLA/WASHER/SCHIBE/LAVE -- M5 (1pz)



DADO /NUT/MUTTE -- M5 (1pz)

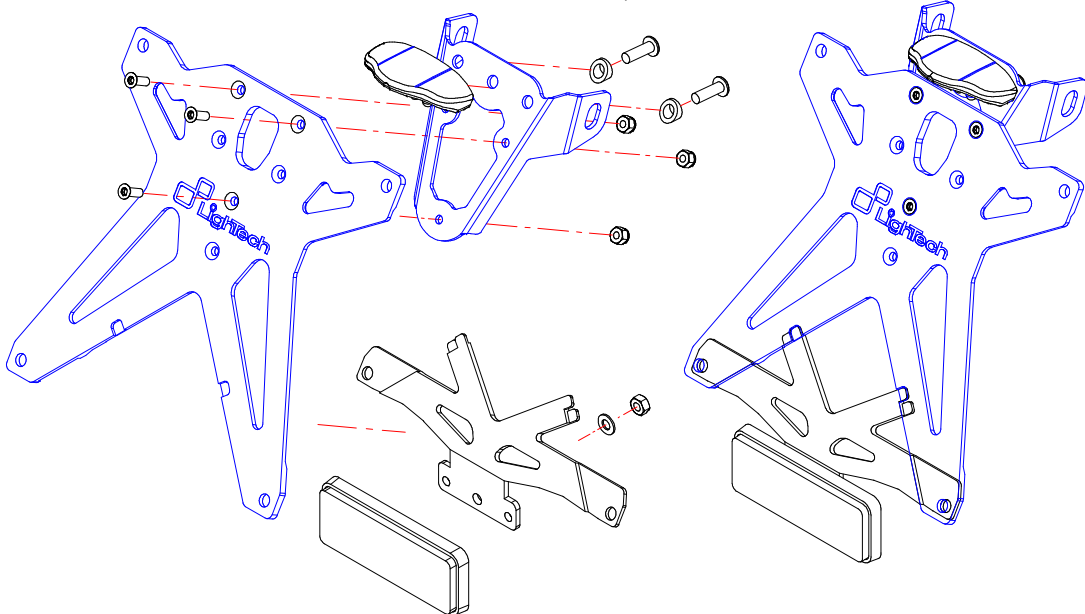

LightTech
Ligtech s.r.l.

31025 - Santa Lucia di Piave (TV) Italy
Tel. 0438 / 453010 - Fax 0438 / 655919
email : info@ligtech.it - web : www.ligtech.it

LightTech
Ligtech s.r.l.

31025 - Santa Lucia di Piave (TV) Italy
Tel. 0438 / 453010 - Fax 0438 / 655919
email : info@ligtech.it - web : www.ligtech.it

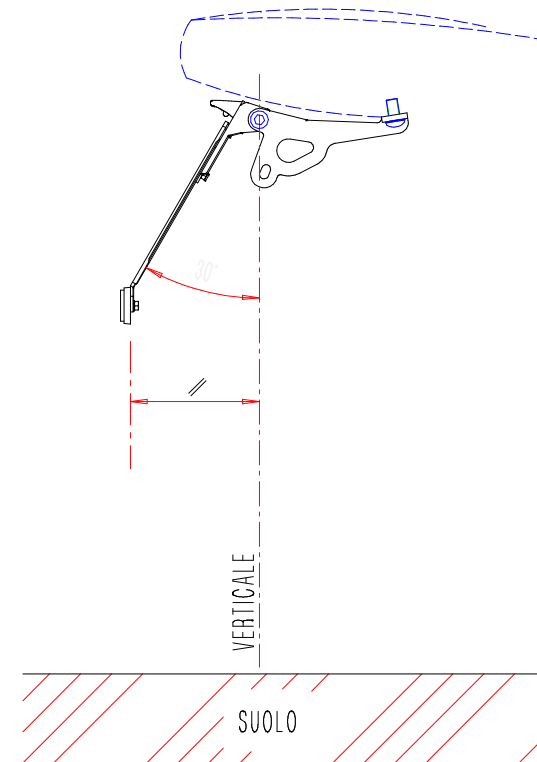

- IL CODICE DELLA STRADA (ART. 259) FISSA LE MODALITA' DI INSTALLAZIONE DELLE TARGHE DI CUI A SEGUITO SI RIPORTANO I PUNTI FONDAMENTALI :
 - SE LA FORMA DEL VEICOLO LO RICHIEDE LA TARGA PUO' ESSERE INCLINATA ALL'INDIETRO DI 30° RISPETTO ALLA VERTICALE.
 - SE LA TARGA A CAUSA DEL SUO IRREGOLARE POSIZIONAMENTO , RISULTA ILLEGGIBILE CONCORRE L'IPOTESI DELL' ART. 102 c.7
- LA LIGTECH srl NON SI ASSUME RESPONSABILITA' PER UTILIZZI NON A NORMA CON IL CODICE STRADALE

ADJUSTING THE ANGLE PLATE UNDER THE CODE IN FORCE IN THE COUNTRY IN USE
LIGTECH LTD WILL NOT ASSUMES ANY RESPONSIBILITY , FOR USE IN ACCORDANCE WITH THE TRAFFIC

REGELN DER STURZ DEN KENNZEICHEN AUF GRUND AN DER KODE IM LAND IN BENUTZUNG GELTEND
LIGTECH SRL NEHME KEINEN VERANTWORTUNGEN AN FUR NUTZUNGEN NICHT IM NORM MIT DEM TRAFFIC KODE.

REGLER L'INCLINATION SUPPORT DE PLAQUE EN BAS AU CODE EN VIGUER DANS LA NATION EN USAGE
LIGTECH SRL NASSUME PAS AUCUNE RESPONSABILITE POUR UTILISATION PAS à NORME AVEC LE CODE DE LA ROUTE