

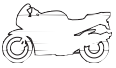

07H00130 51.6 x 51.6 x 19.5
52.0 x 52.0 x 13.7

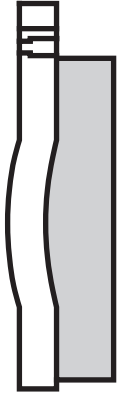
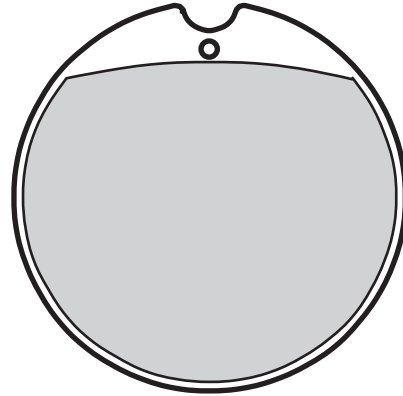
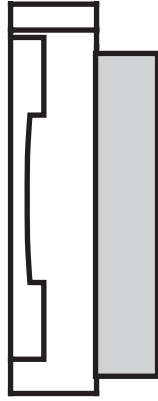
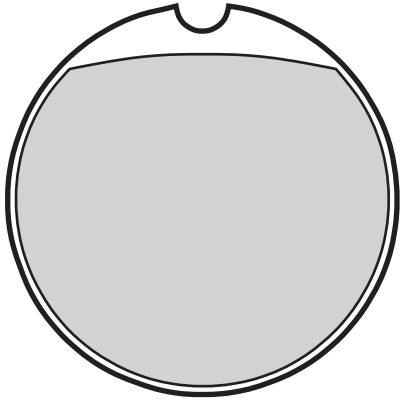

HONDA

250	CB	71	●	-
250	CB G,T	74->76	●	-
250	CJT	76->78	●	-
350	CB F, F1	73->76	●	-



360	CB G, T	73->76	●	-
360	CJT	76->78	●	-
360	CL K1	74	●	-
400	CB F, F1, F2	75->79	●	-
450	CB K5, K6, K7	72->77	●	-
500	CB F	72->75	●	-

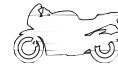

500	CB K1, K2, K3	72->77	●	-
500	CB T, T1	75->78	●	-
550	CB F1, F2	75->79	●	-
550	CB K2, K3	74->78	●	-
750	CB A, K	76->77	●	-
750	CB F1	75->77	●	-



07H00229 49.9 x 49.9 x 20.0
49.9 x 49.9 x 13.5

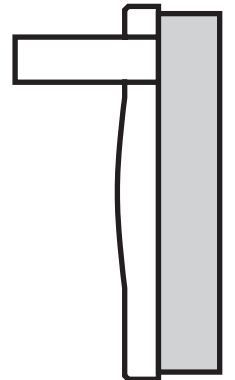
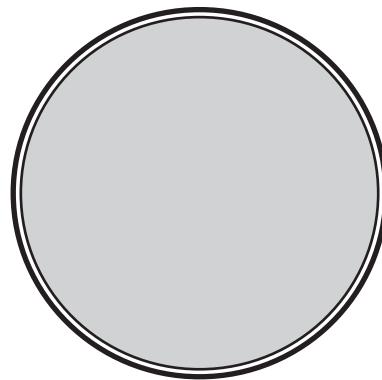

HONDA

450	CB K3, K4	71->72	●	-
750	CB K	70->76	●	-



3





07H00307 67.0 x 49.0 x 9.5

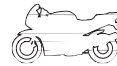
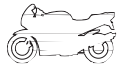
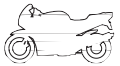
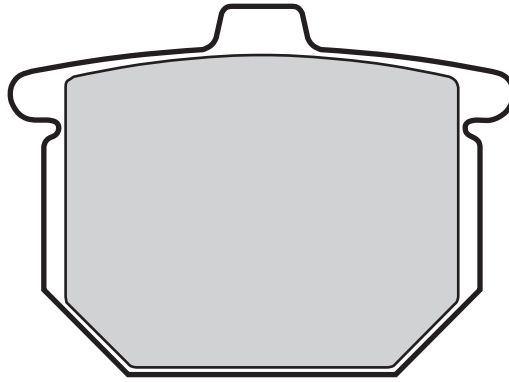

HONDA

125	MT R	78	•	-
400	CB NA, NB	78	•	-
400	CB NZ	79	•	-
400	CB	78->82	•	-
400	CX	81	•	-

400	GL	77->80	•	-
500	CX	78->80	•	-
750	CB F	77->80	•	•
750	CB F2, SS	77->79	•	•
900	CB F	78->80	•	•

1000	CBX	78->80	•	•
1000	GL GOLDWING, GRANTOUR	81	•	•
1000	GL K3	78->79	•	•
1100	GL	79	•	•

3



07H00411 57.8 x 65.3 x 10.5

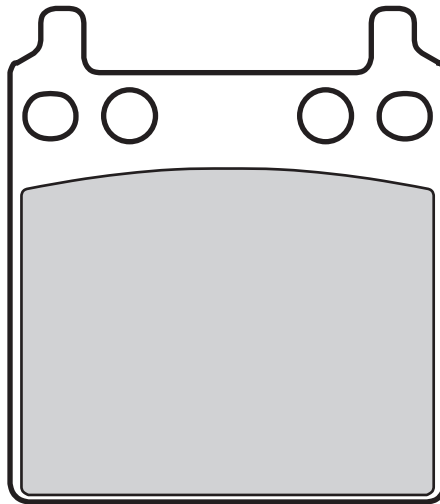

HONDA

750	CB F1	75->77	-	•
1000	GL K1, K2	75->77	-	•





07H00531 45.5 x 45.5 x 20.9
45.5 x 45.5 x 11.7

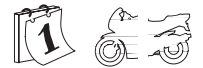
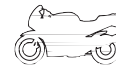
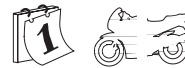
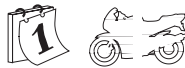
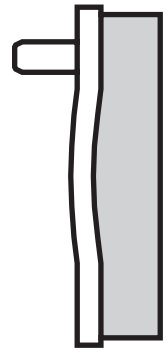
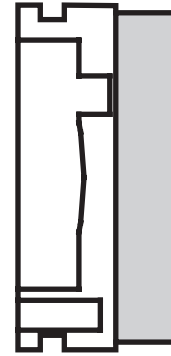
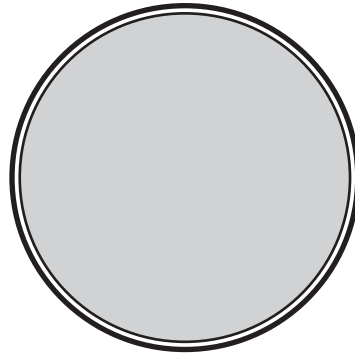

HONDA

125	CB JX	74->76	●	-
125	CB K6	76	●	-
125	CB S, S1, S2, S3	74->78	●	-
200	CB	74	●	-
200	CB T	75->76	●	-



07H00631 39.3 x 39.3 x 21.0
39.3 x 39.3 x 11.0

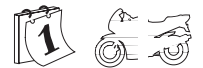
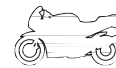
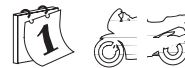
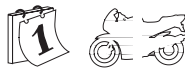
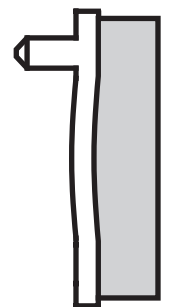
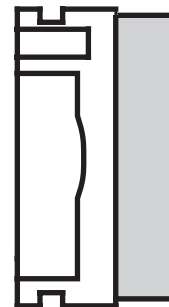
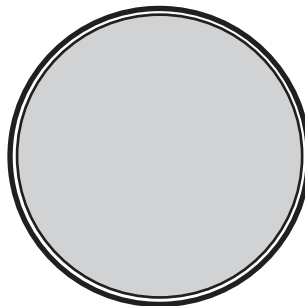

HONDA

50	CB K1, J	75	●	-
50	SS ZB2	75	●	-
90	9CB	79	●	-
110	CB	77	●	-
125	CB	77	●	-

125	CB J	79	●	-
125	MTR	77	●	-

HONDA ITALIA

125	125 4T	75	●	-
-----	--------	----	---	---





07H00712 52.5 x 53.0 x 11.0

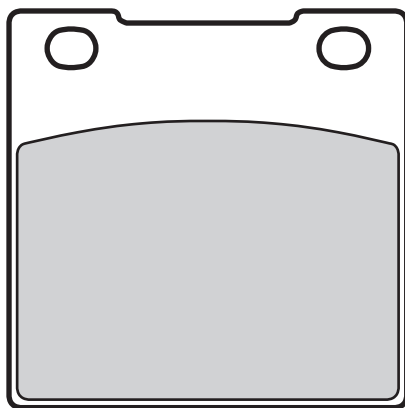

HONDA

250	CB ND	83	•	-
250	CB RS	80->85	•	-
250	CB RSC, RZC	82	•	-
250	CB T, TZ, NA, NB	77	•	-
250	CB PSA, RSA, RDS	80	•	-

250	CB N	78	•	-
250	CM TB	81	•	-
400	CB A, T1, T2	77->81	•	-
400	CB N, T, HAWH	78	•	-
400	CM T	79->84	•	-
400	CM A, T, TZ	79	•	-
400	CM T, CUSTOM	81	•	-

650	CB Z	78->81	•	-
650	CB	80	•	-
750	CB CUSTOM	81	•	-
750	CB C, PZ, K, L	80->81	•	-

3



07H00831 39.3 x 39.3 x 21.0
39.3 x 39.3 x 11.0

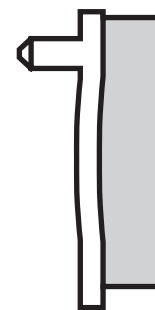
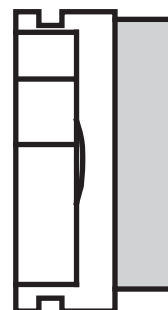
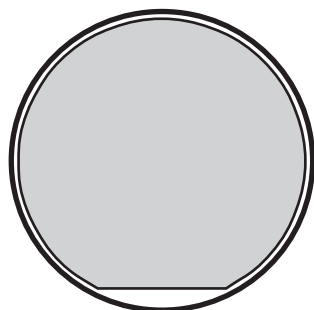

HONDA

100	CB N	79	•	-
125	CB T, T1, T2, TZ	77	•	-
125	CB T	85	•	-
250	FL ODYSSEY	84	•	-





07H00906 41.1 X 45.0 X 8.0

07H009SD 41.1 X 45.0 X 8.0
Sintered

07H009SX 41.1 X 45.0 X 8.0
Sintered

07H009TT 41.1 X 45.0 X 8.0

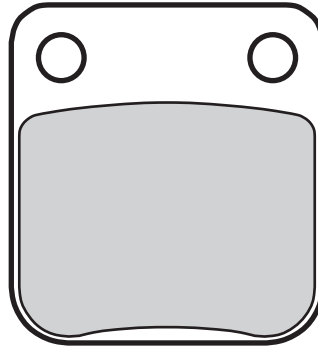

ARCTIC CAT

400 DVX	04->	●	-
---------	------	---	---

DAELIM

50 CORDI	06->	●	-
50 S-FIVE	06->	●	-
125 S2	05->	-	●
250 S2	06->	-	●

HONDA

50 CB (all models)	80->81	●	-
50 CRM	89->92	●	-
50 MB	82	●	-
50 MBX	80	●	-
50 MRX	88	●	-
50 SC 01	91	●	-
50 SP	91	●	-
80 CB	80->81	●	-
80 CR R	86->91	●	-
80 CR R	92->97	●	-
80 MBX FWD	83	●	-
125 CB RS	83	●	-
125 CG	04	●	-
150 CG	04->	●	-
250 ATC R	81	●	-

HUSQVARNA

125 CR	92->94	-	●
125 WR	92->94	-	●
250 CR	92->94	-	●
250 WR	92->94	-	●
350 TE	92->94	-	●



HYOSUNG

400 TE	05->	●	-
450 TE	07->	●	-

KAWASAKI

125 BN ELIMINATOR A1, A2	98->99	●	-
400 KFX	02->	●	-
400 KVF A1, A2, B1 Prairie	97->98	●	-
400 KVF C1, C2 Prairie 4x4	99->	●	-
400 KVF D1, D2 Prairie 2x4	99->	●	-

SUZUKI

125 123 DR SF	85	●	-
125 DR	91->02	●	-
125 GX R	88	●	-
125 RH X	87	●	-
125 SP	85->88	●	-
125 TS X	85	●	-
200 DR	90	●	-
200 SP GHJ	88	●	-
240 RH X	87	●	-
240 TS X	85	●	-
250 DR S, F	85->89	●	-
250 LT-Z Quad Sport	04->	●	-
250 OZARK	03->	●	-
250 RH	85	●	-
250 SP F	85	●	-
250 TS X	85	●	-
400 LT-A Eiger 2WD/4WD	02->	●	-
400 LT-F Eiger 2WD/4WD	02->	●	-
400 LT-Z Quad Sport	02->	●	-
500 LT-A VINSON	02->	●	-

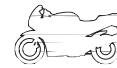

YAMAHA

125 SX R	88	●	-
200 YFS R Blaster	03->	●	-
250 YFM AN Bruin 2x4	05->	●	-
250 YFM Bear Tracker	01	●	-
300 YFM Warrior	89	●	-
350 YFM Bruin 2x4, 4x4	04->	●	-
350 YFM FWB L, LC Big Bear (4WU/EBE)	99	●	-
350 YFM FXG WOLVERINE	95->96	●	-
350 YFM FXG-FXM Wolverine (4KB/EBE)	95->	●	-
350 YFM XG,XH Warrior (3GD/EBE)	95->96	●	-
350 YFM XW, XA-M Warrior	89	●	●
350 YFZ T-W Banshee	87->89	●	-
400 YFM FAM Kodiak	00->	●	-
400 YFM FWN Big Bear 4WD	00->	●	-
400 YFM FWNH Big Bear-Buckmaster 4WD	00->	●	-
400 YFM N Big Bear 2WD	00->	●	-
450 YFM FA_ Kodiak	03->	●	-
450 YFM KODIAK	03	●	-
450 YFM Wolverine	06->	●	-





07HO1010 90.0 x 49.0 x 11.0

07HO10SA 90.0 x 49.0 x 11.0
Sintered

07HO10SP 90.0 x 49.0 x 11.0
Sintered

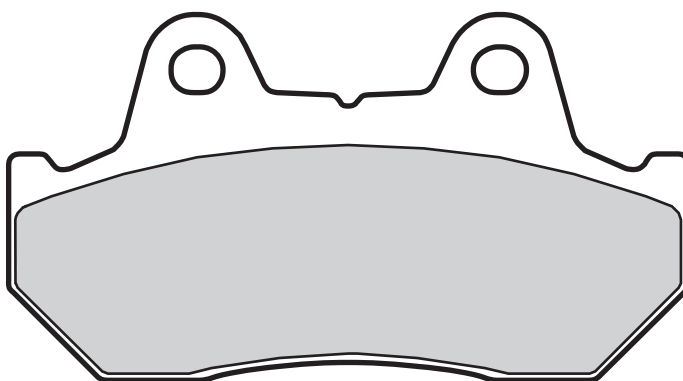

HONDA

125	CB TDC	83	●	-
250	CN HELIX	86->87	●	-
250	CN HELIX	92	●	-
250	GB CLUBMAN	88	●	-
250	NS R	85	-	●
250	NSR R	87	-	●
400	CB	81	●	●
400	CB FOUR	81	●	-
400	CB HAWK	81	●	●
400	CB N	82->85	●	-
400	CB TWIN	82	●	-
400	CBR F, F2	85	●	●
400	CBR R	87	-	●
400	CM C	81	●	-
400	CM T	85	●	-
400	GB TT	88	●	-
400	NS R	85->86	-	●
400	XELVIS	92	●	●
450	CB T	82	●	-
450	CBR SR	91	●	●
450	CM A, C	82	●	-
450	CMX REBEL	86	●	-
500	CB EC	83	-	●
500	CX	81	●	-
500	CX C	81	●	●
500	CX E	85	●	●
500	CX EURO	82	●	-
500	CX SILVER WING TURBO	81->83	●	●
500	CX TURBO	81->83	●	-
500	FT	82->83	●	●



500	GB TT	88	●	-
500	GL	81->82	-	●
500	GL D	81	●	-
500	NS R	85	●	●
500	VF 2	83	-	●
500	VT C	83->86	●	-
500	XBR S	85	●	-
550	CB SC	83	●	-
550	CBX	82	●	●
600	CBR F	87->90	-	●
600	CBX E	85	●	-
600	XL LM	85->87	●	-
600	XL V TRANSALP	87->90	●	-
650	CB	85	●	-
650	CB SC	83	●	-
650	CBX ED, SC, SCD	83	●	-
650	CX C, T, TD, TURBO	83	●	●
650	CX E	83	-	●
650	GL D	83	●	-
700	CB SC	84	●	-
700	VF F, INTRUDER	84->85	-	●
700	VF S, C	84	●	-
700	VFC MAGNA	84	●	-
700	VFC MAGNA	87	●	-
700	VFR F, F2	86->87	-	●
700	VT C, SHADOW	87	●	-
750	CB F, F2, K	85	●	-
750	CB F, K	81->82	●	●
750	CB SC, KZ, C	82->83	●	-
750	CBR HURRICANE	87	-	●
750	CBX, F	84	●	●
750	NV CG, SHADOW	86	●	-



750	VF C	88->93	●	-
750	VF CUSTOM, SPORT	82->83	●	-
750	VF F	83	●	●
750	VF S	85	●	-
750	VFR FJ, F	86->87	-	●
750	VP CH, CUSTOM	87	●	-
750	VT C, SHADOW	86->96	●	-
750	XLV R	83->85	●	-
800	VT C	88	●	-
900	CB C	82	●	●
900	CB F, F2 BOL D'OR	81->84	●	●
1000	CB C	83	●	●
1000	CBR F	87->88	-	●
1000	CBX	81->82	-	●
1000	VF F	84	●	●
1000	VF F2 BOL D'OR, F, F2	85	●	●
1000	VF R	84->86	●	-
1000	VT C	88	●	-
1100	CB F	83->85	●	●
1100	CB R, RB, RC	81	●	●
1100	CB RD	83	●	●
1100	GL	81->83	●	●
1100	VF C, S	83	-	●
1100	VT SHADOW	87->93	●	-
1200	GL A, I	84	●	●
1200	GL DX	86	●	●
1200	GL GOLDWING	84	●	●
1500	GL ASPENCADE, SE	94->97	-	●
1500	GL GOLDWING SE	88->93	-	●
1500	GL GOLDWING SE	88	-	●
1500	GLX	88	-	●





07H01118 85.0 x 42.4 x 7.8
47,5 x 37.0 x 10.0

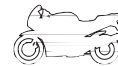
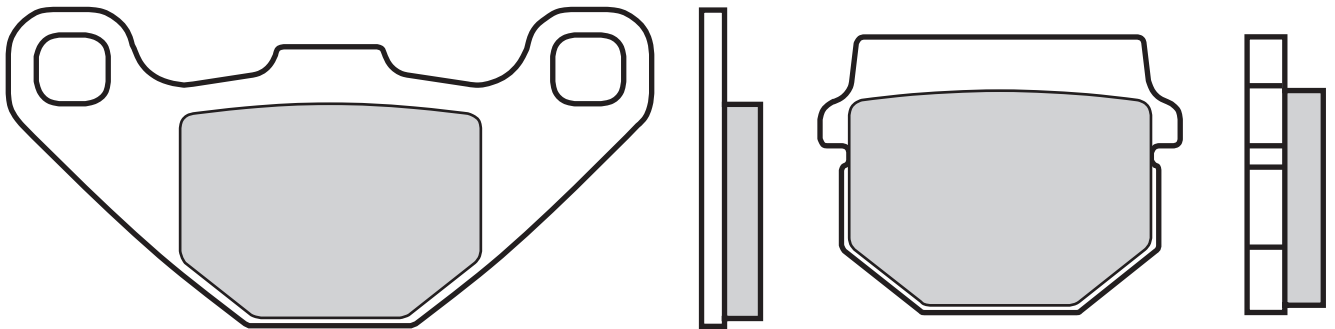

HM

50	CRE	98	-	•
50	CRE BAJA	97	•	•

HONDA

80	MB	80	•	-
80	M CX	82	•	-

KAWASAKI

80	KMX	87	•	-
125	KMX	87->90	•	-

SUZUKI

50	TUNE	92	•	-
50	ZZ	92	•	-
80	RM G	86->89	•	-
80	RM L, M, N	90->95	•	-
125	AN	93	•	-



07H01212 67.0 x 49.0 x 12.0

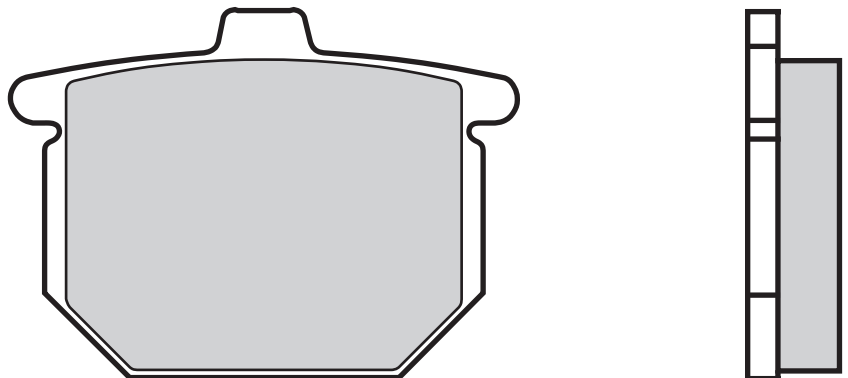

HONDA

750	CB F2, SS	77->79	•	-
1000	GL K1, K2	75->77	•	-





07HO1406 91.7 x 53.2 x 8.0

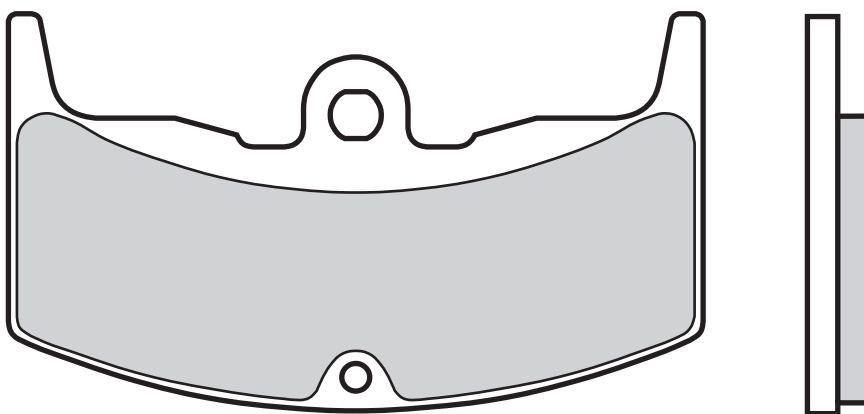

HONDA

250	VT E, FD	83	●	-
250	VT F	83->87	●	-
250	VTR	88->89	●	-
400	CBX F, F2, F2C	82	●	-
400	VF F	85	●	-
400	VF FD	83	●	-

400	VT E	83	●	-
400	VT FD	83	●	-
500	VT E	83	●	-
500	VT ED	82	●	-
550	CBX F, F2, FC, F2C	82	●	-
650	CBX E	83	●	-
900	CB FC, F2C	82	●	-

3



07HO1505 80.9 x 41.7 x 7.3

07HO15SD 80.9 x 41.7 x 7.3
Sintered

07HO15SX 80.9 x 41.7 x 7.3
Sintered

07HO15TT 80.9 x 41.7 x 7.3

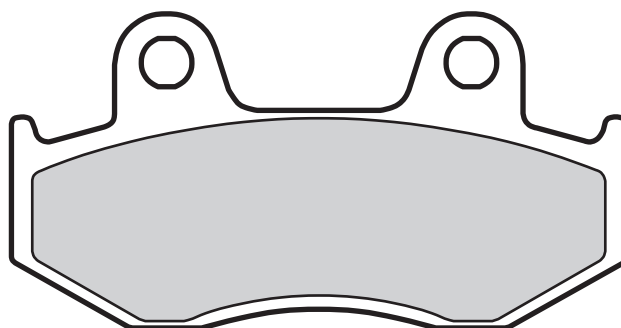

HONDA

80	MBX	86	●	-
80	MTX R	87	●	-
125	CH SPACY	94	●	-
125	CR R	84->86	●	-
125	MTX R	84->85	●	-
125	XL R	86	●	-
200	ATC R	85	●	●
200	MTX R	86	●	-
250	ATC R	85->86	●	●
250	ATC X	85	●	-

250	CB RS	86	●	-
250	CH SPACY	85	●	-
250	CR R	84->86	●	-
250	FTR	86	●	●
250	TRX R	86->89	●	●
250	TRX X Fourtrax	87	●	●
250	XL R	84->87	●	-
250	XLR R	88	●	-
250	XR RE	84->87	●	-
350	ATC X	85	●	-
350	XL R	84->86	●	-
350	XL R ND 03	84	●	-

350	XR R	84->85	●	-
500	CR R	84->86	●	-
500	XL R	83->84	●	-
500	XR R	83->86	●	-
600	XL R	83	●	-
600	XL R, RD, LD	83	●	-
600	XLM LM	87	●	-
600	XR R	83->87	●	-

HONDA ITALIA

125	MTX	90	●	-
-----	-----	----	---	---





07H01609 89.9 x 51.1 x 9.9

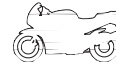
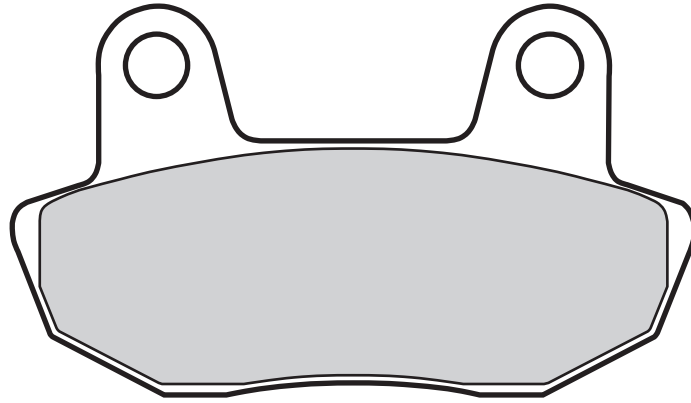

HONDA

450	CB N	84->85	●	-
450	CB SC NIGHTHAWK	82	●	-
650	CB SCC NIGHTHAWK	82	●	-
700	VT C, SHADOW	84->86	●	-
750	VT C	83->85	●	-

3



07H01708 91.7 x 53.2 x 9.5

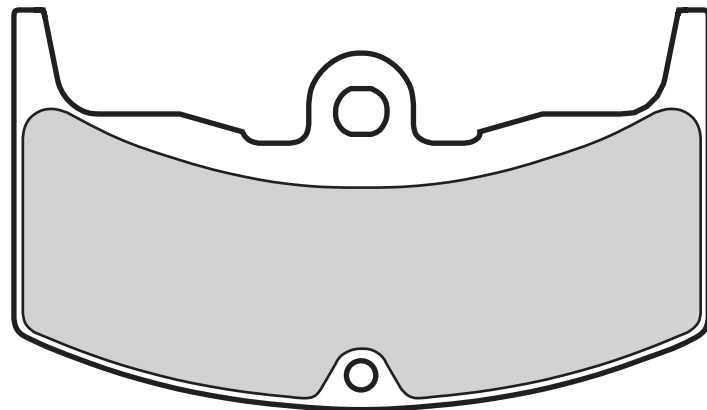

HONDA

400	CBX CUSTOM	88	●	-
400	CBX F	85	●	●
400	CBX F, F2, F2C	82	-	●
400	NV CUSTOM	88	●	-
400	VF F	85	-	●

400	VF FD	83	-	●
400	VT E	83	-	●
400	VT FD	83	-	●
550	CBX F, F2, FC, F2C	82	-	●
900	CB FC, F2C	82	-	●





07HO1807 89.9 x 49.0 x 9.0

07HO18SP 89.9 x 49.0 x 9.0
Sintered

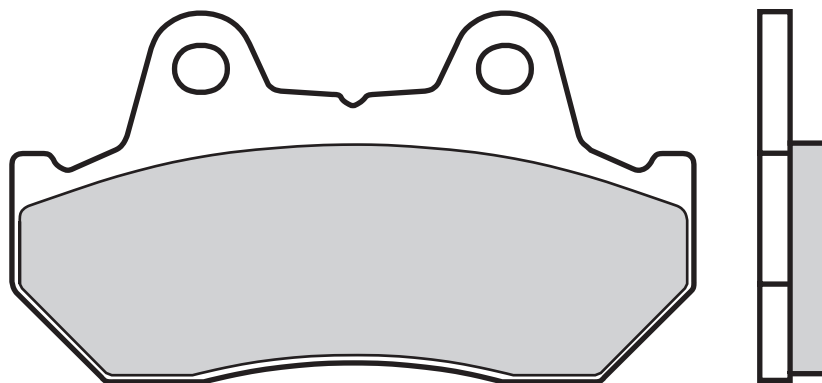

HONDA

125	CB T, SUPERDREAM	82	•	-
125	CBX F	88	•	-
250	CBX RSE	84	•	-
250	CBX S	88	•	-
250	NS R	85	•	-
400	NS R	85->86	•	-

400	VF INTEGRA	86	•	•
450	CB SC NIGHTHAWK	83->86	•	-
500	CB EC	83	•	-
500	CX EURO	82	-	•
500	CX TURBO	81->83	-	•
500	GL	81->82	•	-
500	VF 2	83	•	-
650	CX E	83	•	-

700	VF F, INTRUDER	84->85	•	-
700	VFC MAGNA	85->86	•	-
750	XLV R	86	•	-
1000	CBX	81->82	•	-
1100	VF C, S	83	•	-

3



07HO1912 49.9 x 54.8 x 11.3

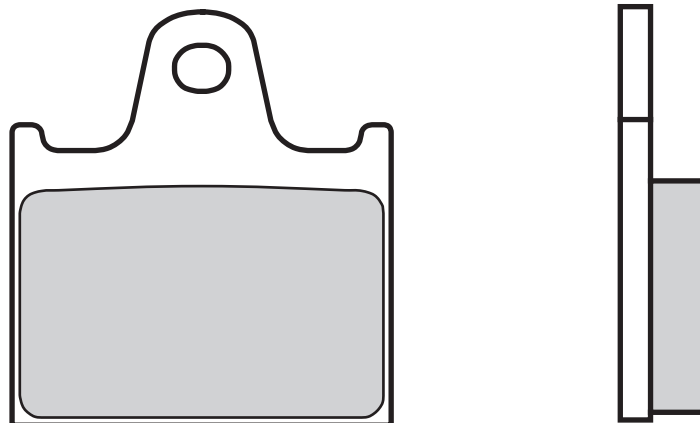

HONDA

1000	VF R	84->86	-	•
------	------	--------	---	---





07HO20SD 45.9 X 45.0 X 6.5/7,5
Sintered

07HO20TT 45.9 X 45.0 X 6.5/7,5

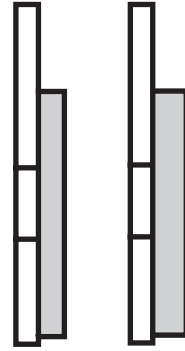
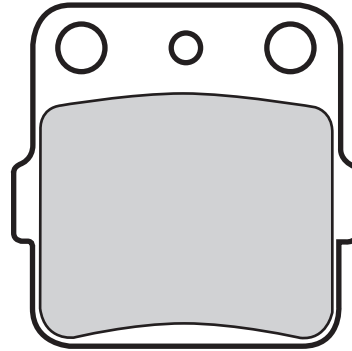

HONDA

200	ATC XD	83	-	•
200	ATC X	83->85	-	•
250	ATC R	82->84	-	•
250	ATC X	85	-	•
350	ATC X	85	-	•
350	ATC X	86	-	•



SUZUKI

230	LT SG	86	-	•
-----	-------	----	---	---

TM

80	JUNIOR	96	-	•
----	--------	----	---	---



3



07HO2107 81.1 X 42.1 X 8.9

07HO21SA 81.1 X 42.1 X 8.9
Sintered

07HO21SC 81.1 X 42.1 X 8.9
Sintered

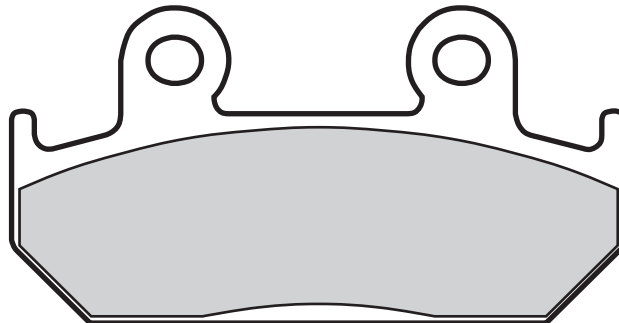

HONDA

250	CBR F	86	•	-
250	CBR HURRICANE	87	•	-
250	NSR R	87	•	-
250	VT F	88	•	-
250	VTR	90->97	•	-
250	VTZ	88	•	-



350	CB S, G	87	•	-
350	NX	92	•	-
400	CB N	86	•	-
400	CBR F	92	•	-
400	CBR R	87	•	-
400	VFR R	86->87	•	•
400	VFR R	87->90	•	-
400	VFR Z	88	•	-



450	CB S	86	•	-
600	CBR F	87->90	•	-
600	CBR F, SUPER SPORT	91->94	•	-
600	NTV REVERE	88	•	-
600	VT SHADOW CUSTOM	89->91	•	-
750	XRV AFRICA TWIN	90->92	•	-





07HO2205 45.9 X 45.0 X 6.5

07HO22SD 45.9 X 45.0 X 6.5
Sintered

07HO22SX 45.9 X 45.0 X 6.5
Sintered

07HO22TT 45.9 X 45.0 X 6.5

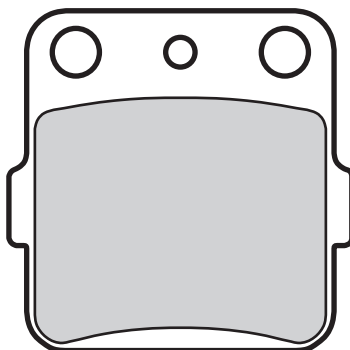

HONDA

75	CRM R	92	•	-
80	CR	03	•	-
80	CR R, RB	96->02	•	-
80	CRM	89	•	-
85	CR R	03	•	-
150	CRF	07->	•	-
200	ATC X	83->85	•	-
200	ATC XD	83	•	-
250	ATC R	82->84	•	-

KAWASAKI

65	KX	00	-	•
80	KX	97->00	-	•



80	KX L, N, R	88->96	-	•
85	KX, II	01	-	•
100	KX	88->96	-	•
100	KX	97	-	•

SUZUKI

65	RM	03	-	•
100	RM	03	-	•
125	RM H	87->88	-	•
230	LT EH, S	86->93	-	•
230	LT SF-SJ	85->88	-	•
250	LT RF-RH	85->87	-	•
250	LT SK, SL	89->90	-	•
250	RM H	87->88	-	•
800	DR Z	88->90	-	•



YAMAHA

125	YZ	89	-	•
250	YZ	89	-	•
300	YFM Warrior	89	-	•
350	YFM FXG WOLVERINE	95->96	-	•
350	YFM XT	87->88	-	•
350	YFZ A-M Banshee	90->	-	•
350	YFZ T-W Banshee	87->89	-	•
360	YZ	89	-	•
600	YFM GRIZZLY	98	•	-
660	YFM RAPTOR	01	•	•

3



07HO2307 88.2 X 46.1 X 8.4

07HO23SA 88.2 X 46.1 X 8.4
Sintered

07HO23SP 88.2 X 46.1 X 8.4
Sintered

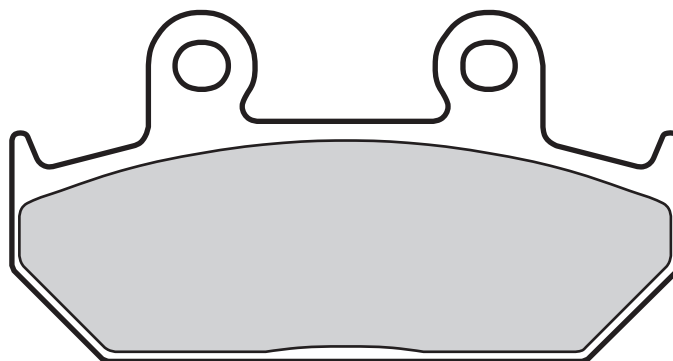

CAGIVA

600	CANYON	95	•	-
-----	--------	----	---	---

HONDA

125	RS (GP)	88->90	•	-
250	CB	88->91	•	-



250	CD	88	•	-
400	STEED	88->91	•	-
600	NV C	88	•	-
600	NX DOMINATOR	93	•	-
600	STEED	88->91	•	-
650	NX DOMINATOR	93->96	•	-
700	VFR F, F2	86->87	•	-



750	CBR HURRICANE	87	•	-
750	VFR FJ, F	86->87	•	-
1000	CBR F	87->88	•	-





07H02408 54,9 x 52.4 x 9.4

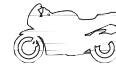
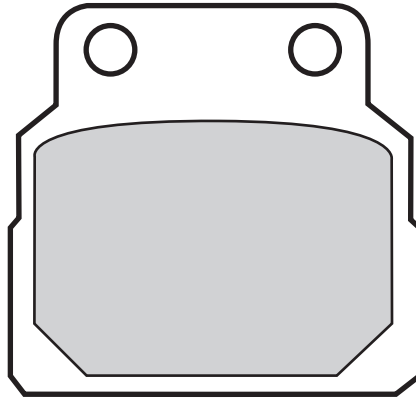

HONDA

450	CB DX	89	•	•
450	CB N	86	•	-



07H02506 94.0 x 31.9 x 7.4

07H025SD 94.0 x 31.9 x 7.4
Sintered

07H025SX 94.0 x 31.9 x 7.4
Sintered

07H025TT 94.0 x 31.9 x 7.4

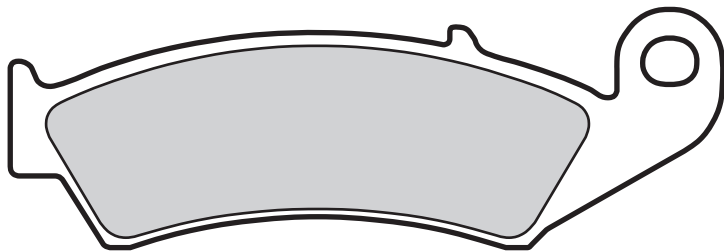

HONDA

	AX 1	88	•	-
125	CR R, RK	87->94	•	-
250	AX-1	90	•	-
250	CR R	87->94	•	-

250	CRM R	90	•	-
250	NX	88->90	•	-
250	TRX R	86->89	•	-
250	TRX X Fourtrax	87	•	-
250	XL DEGREE	91	•	-
250	XLR BAJA	88->90	•	-

250	XR R	88->89	•	-
250	XR R, L	90->93	•	-
350	ATC X	86	•	-
500	CR	87->94	•	-
600	XR R	88->90	•	-
600	XR R	91->92	•	-

3





07HO2608 74.0 x 36.1 x 9.5

07HO26SD 74.0 x 36.1 x 9.5
Sintered

07HO26SX 74.0 x 36.1 x 9.5
Sintered

07HO26TT 74.0 x 36.1 x 9.5

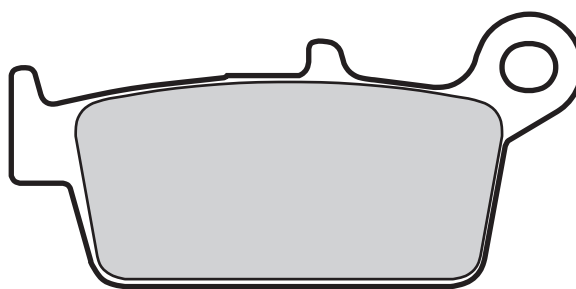

FANTIC MOTOR

5065	MX Regolarità competizione	08->	-	●
85	MX Regolarità competizione	08->	-	●
125	MX Regolarità competizione	08->	-	●

GAS GAS

125	EC	00->	-	●
125	MC	03	-	●
125	SM	02	-	●
200	EC	00->	-	●
200	HOBBY	07->	-	●
250	EC	00->	-	●
250	MC	00->	-	●
250	SM	02	-	●
300	EC	00->	-	●
400	EC	02	-	●
400	FSE SM	02	-	●
400	PAMPERA	06->	-	●
450	EC	03	-	●
450	FSE SM	03->06	-	●
450	FSE EC	03	-	●
450	FSR	07->	-	●
450	SM FSR	07->	-	●
500	FSE EC	06->	-	●
515	FSR	08->	-	●

HM

50	CRE	06->	-	●
125	CRE ENDURO	95->01	-	●
125	CRE SUPERMOTARD	03	-	●
125	CR R SUPERMOTARD	04->	-	●
125	SUPERMOTARD	00	-	●
250	CRE ENDURO	95->01	-	●
250	CRE SUPERMOTARD	03	-	●
250	CRE SUPERMOTARD	04->	-	●
250	SUPERMOTARD	00	-	●
450	CRF SUPERMOTARD	02->	-	●

HONDA

	AX 1	88	-	●
50	CB Replica	99	-	●
50	SKY CLASSIC, VETRO	00	-	●
80	MB	80	-	●
80	MCX S	82	-	●



80	MCX	82	-	●
80	MTX R	87	-	●
125	CA REBEL	95->96	-	●
125	CR R, RK	87->94	-	●
125	CR RK	95->01	-	●
230	SL	97	-	●
250	CR R	87->94	-	●
250	CR R	95->01	-	●
250	XLR BAJA	88->90	-	●
250	XLR R, SPL	94	-	●
250	XR R, L	90->93	-	●
250	XR R, L, S	94	-	●
400	XR	96	-	●
400	XR SUPERMOTARD	00	-	●
440	XR R	00	-	●
500	CR	87->94	-	●
500	CR	95->01	-	●
600	XR R	91->92	-	●
600	XR R	93	-	●
650	BROS	88	-	●
650	NTV HAWK	89->91	-	●
650	XR L	93	-	●
650	XR R	00	-	●

HYOSUNG

400	XRV	05	-	●
-----	-----	----	---	---

KAWASAKI

125	KX	95	-	●
250	KLX	98	-	●
250	KX	95	-	●
300	KLX R	97	-	●
400	KLX R/SR	03	-	●
500	KX	96	-	●
650	KLX R	96->98	-	●

SHERCO

450	ENDURO	04	-	●
-----	--------	----	---	---

SUZUKI

125	RM T	96->05	-	●
250	DR Z	01	-	●
250	RM T	96->05	-	●
250	RMX	99	-	●
400	DR-Z S/E	00->04	-	●



TM

85	85	01	-	●
125	125	01->04	-	●
125	ENDURO	01->04	-	●
125	SMR	05	-	●
125	SMX	06	-	●
250	E	01	-	●
250	E 4-stroke	01->04	-	●
250	250	01->04	-	●
250	250 4-stroke	01	-	●
300	300	01	-	●
300	E	01->04	-	●
400	SMR F	02	-	●
400	SMR F	03	-	●
400	4T	01	-	●
400	E 4 stroke	01	-	●
450	SMR F	04	-	●
450	SMX F	03	-	●
450	4T	02->04	-	●
450	ENDURO 4 stroke	02->04	-	●
530	4T	01->04	-	●
530	E 4 stroke	01->04	-	●
530	SMR F	03	-	●
530	SMR F ES	03	-	●
600	SMX F	03	-	●
660	SMX F	05	-	●

YAMAHA

125	YZ	98->02	-	●
125	WR	98	-	●
250	YZ	98->02	-	●
250	YZ F	01->02	-	●
250	WR	98->02	-	●
250	WR F	01->02	-	●
400	YZ F	99->02	-	●
400	WR F	99->00	-	●
426	YZ F	00->02	-	●
426	WR F	01->02	-	●





07H02711 86.1 x 39.9 x 10.7

07H027SP 86.1 x 39.9 x 10.7

Sintered

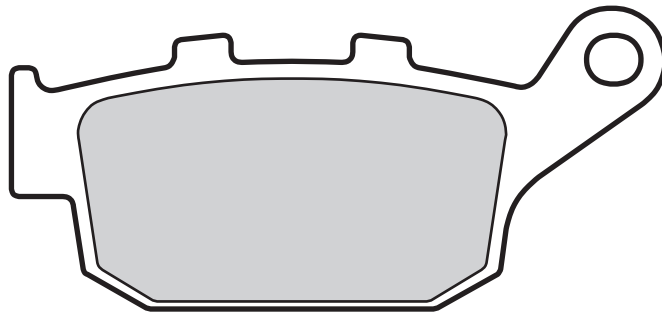

BUELL

500	BLAST	01	-	●
984	XB 8 R	02	-	●
984	XB 8 S	03	-	●
984	XB 9 SX CITY X	05	-	●
1200	M2	98->02	-	●
1200	RS X1	98	-	●
1200	S1 LIGHTNING	98->02	-	●
1200	S1 WHITELIGH TWING	98->02	-	●
1200	S3 THUNDERBOLT	98->02	-	●
1200	XB12 R	04	-	●
1200	XB12 S	04	-	●
1200	XB12 S LIGHTNING LONG	06->	-	●
1200	XB12 X ULYSSES	06->	-	●

HONDA

250	CBR HURRICANE	87	-	●
250	CBR RJ	88	-	●
250	CBR R, RR	90	-	●
250	NSR RJ, R, SP	88	-	●



250	RS R	91->92	-	●
250	VT SPADA	89	-	●
250	VTR	98	-	●
400	BROS 2	88	-	●
400	CB FK	90	-	●
400	CB SUPER FOUR	92	-	●
400	CB-1	89->90	-	●
400	CBR RR	88->94	-	●
400	VFR R	91	-	●
400	VFR Z	88	-	●
400	VRX T ROADSTAR		-	●
600	NTV BROS 1	88	-	●
600	NTV REVERE	88	-	●
600	NX DOMINATOR	93	-	●
600	XL V TRANSALP	91->93	-	●
600	XL V TRANSALP	94->96	-	●
600	XL V TRANSALP	97->99	-	●
650	FMX	05	-	●
650	NTV REVERE	88->93	-	●
650	NTV	94	-	●
650	NTV DEAUVILLE	98->00	-	●

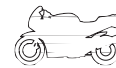

650	NTX BROS	90	-	●
650	NX DOMINATOR	88->92	-	●
650	NX DOMINATOR	93->96	-	●
650	XLV TRANSALP	00	-	●
650	XRV AFRICA TWIN	88	-	●
700	VF F, INTRUDER	88->89	-	●
750	CB NIGHTHAWK	91	-	●
750	XRV AFRICA TWIN	90->92	-	●
750	XRV AFRICA TWIN	93	-	●

SUZUKI

650	XF FREEWIND	97	-	●
-----	-------------	----	---	---

TRIUMPH

600	DAYTONA	04	-	●
600	SPEED FOUR	03	-	●
600	TT	00	-	●
650	DAYTONA	05	-	●
675	DAYTONA	06->	-	●
675	Street Triple	08->	-	●
1050	SPRINT ST	05->	-	●

3





07HO2807 67.8 x 53.7 x 8.1

07HO28RC 67.8 x 53.7 x 8.1

07HO28SA 67.8 x 53.7 x 8.1

Sintered

07HO28SC 67.8 x 53.7 x 8.1

Sintered

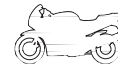
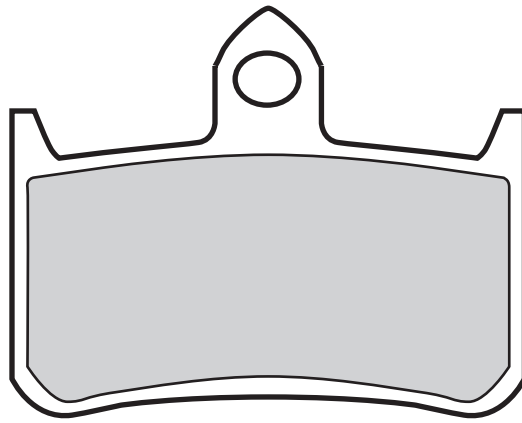

HONDA

125	NS	89	●	-
250	NS	89	●	-
250	NSR RJ, R, SP	88	●	-
250	RS R	91->92	●	-
400	BROS 2	88	●	-

400	RVF RR	90	●	-
400	VFR R	91	●	-
400	VTR R	90	●	-
600	NTV BROS 1	88	●	-
650	BROS	88	●	-
650	NTX BROS	90	●	-
750	NR	92	●	-

750	RVF (RC 45)	94	●	-
750	VFR R (RC 30)	88->93	●	-
900	CBR RR	92->97	●	-
900	HORNET	02	●	-
1000	CB BIG ONE	93->95	●	-
1000	VTR F FIRESTORM	97	●	-

3



07HO2911 94.0 x 31.9 x 8.4

07HO29SP 94.0 x 31.9 x 8.4

Sintered

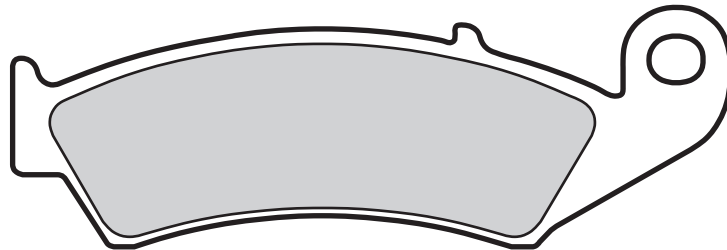

HONDA

400	RVF RR	90	-	●
400	VFR R	87->90	-	●
400	VTR R	90	-	●
750	RVF (RC 45)	94	-	●
750	VFR R (RC 30)	88->93	-	●





07H03005 102.1 x 38.9 x 8.1

07H030SA 102.1 x 38.9 x 8.1
Sintered

07H030SC 102.1 x 38.9 x 8.1
Sintered

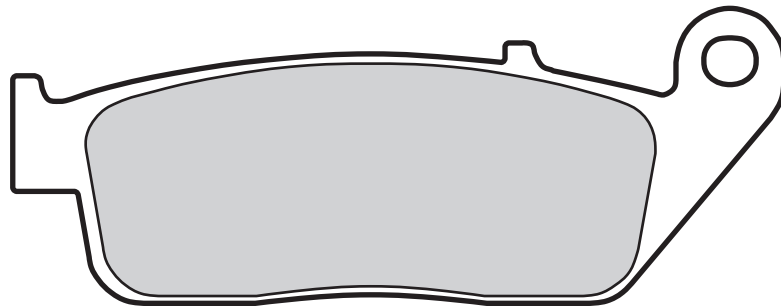

BUELL

500	BLAST	01	●	-
-----	-------	----	---	---

CAGIVA

900	GRAN CANYON	99	●	-
1000	NAVIGATOR	00	●	-

HONDA

125	RS (GP)	91->94	●	-
125	XLR R	98	●	-
125	XR L	03	●	-
250	CB	92	●	-
250	CBR RJ	88	●	-
250	CBR R, RR	90	●	-
250	CBR NIGHTHAWK	92	●	-
250	CN HELIX	93	●	-
250	STEED	93	●	-
250	VT SPADA	89	●	-
400	CB FK	90	●	-
400	CB-1	89->90	●	-
400	CBR RR	88->94	●	-
400	STEED	92	●	-
400	VRX T ROADSTAR		●	-
500	CB	94->96	●	-
600	CBF S	04->07	●	-
600	CBR F3	95->98	●	-
600	HORNET	98->06	●	-
600	HORNET	07->	●	-
600	STEED	92	●	-
600	VT C, SHADOW	93	●	-
600	VT CD SHADOW VLX	94	●	-
650	FMX	05	●	-
650	NTV HAWK	89->91	●	-



650	NTV REVERE	88->93	●	-
650	NTV	94	●	-
700	VF F, INTRUDER	88->89	●	-
750	CB NIGHTHAWK	91	●	-
750	CB N, SEVEN FIFTY	92	●	-
750	VFR F	88->89	●	-
750	VFR F	90->97	●	-
800	PC	89->97	●	-
950	VFR F	92	●	-
1000	CBR F, FJ, FK	89->92	●	-
1000	VF R	89	●	-
1100	ST PAN EUROPEAN	90->02	●	-
1100	VT SHADOW	94->96	●	-
1100	VT SHADOW C2	95->98	●	-
1100	VT SHADOW C3	99	●	-
1100	VT C2 Y	00	●	-
1300	VTX	03	●	-
1300	VTX C	04	●	-
1500	GL C VALKYRIE	96	●	-
1520	GLX	97	●	-

HYOSUNG

125	V2	99	●	-
250	AQUILA	00	●	-

KAWASAKI

750	Z 750	07->	●	-
750	Z 750 ABS	07->	●	-

PEUGEOT

125	SATELIS ABS	04	●	-
400	GEOPOLIS	08->	●	-
600	SATELIS ABS	04	●	-

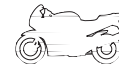

SUZUKI

250	GSF IMPULSE	95	●	-
400	GSX IMPULSE	94	●	-
400	RF	93	●	-
600	GSF BANDIT	96	●	-
600	RF R	93->96	●	-
650	BURGMAN	02	●	-
650	BURGMAN EXECUTIVE	04->	●	-

TRIUMPH

675	Street Triple	08->	●	-
800	AMERICA	03	●	-
800	BONNEVILLE	01	●	-
800	BONNEVILLE AMERICA	02	●	-
800	BONNEVILLE BLACK	04	●	-
800	BONNEVILLE T100 PAUL SMITH	06->	●	-
800	SPEEDMASTER	03->04	●	-
885	THUNDERBIRD SPORT	04->	●	-
900	ADVENTURER	96	●	-
900	America	07->	●	-
900	LEGEND TT	99	●	-
900	SCRAMBLER	06->	●	-
900	TIGER	99->00	●	-
900	THUNDERBIRD	96->	●	-
900	THUNDERBIRD	03->	●	-
900	THRUXTON	04->	●	-
955	TIGER	04	●	-

VOXAN

1000	SCRAMBLER	01	●	-
------	-----------	----	---	---



07H03109 102.1 x 38.9 x 9.6

07H031SP 102.1 x 38.9 x 9.6

Sintered

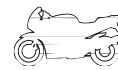
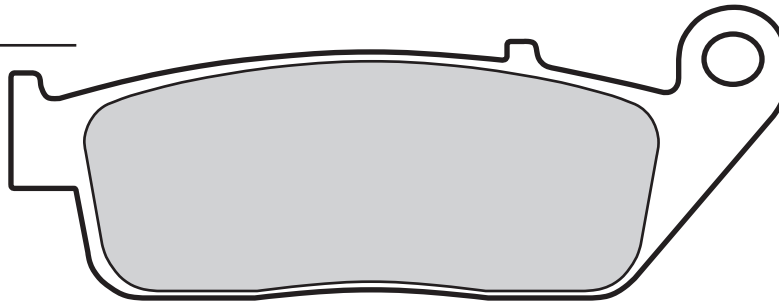

DAELIM

125	DAYSTAR	00->	•	-
125	ROADWIN	04->	•	-
125	ROCKET	99	•	-
125	S2	05->	•	-
125	VL DAYSTAR	00	•	-
125	VT EVOLUTION	00	•	-
125	VT MAGNA	99	•	-
150	ROADWIN X5	06->	•	-

250	ROADWIN	08->	•	-
250	S2	06->	•	-

HONDA

750	VFR F	88->89	-	•
750	VFR F	90->97	-	•
950	VFR F	92	-	•
1000	CBR F, FJ, FK	89->92	-	•
1000	VF R	89	-	•
1500	GL C VALKYRIE	96	-	•

1520	GLX	97	-	•
------	-----	----	---	---

TRIUMPH

885	THUNDERBIRD SPORT	04->	-	•
900	ADVENTURER	96	-	•
900	LEGEND TT	99	-	•
900	THUNDERBIRD	96->	-	•
900	THUNDERBIRD	03->	-	•
900	TIGER	99->00	-	•

3



07H03405 102.1 x 38.9 x 10.4

07H034SP 102.1 x 38.9 x 10.4

Sintered

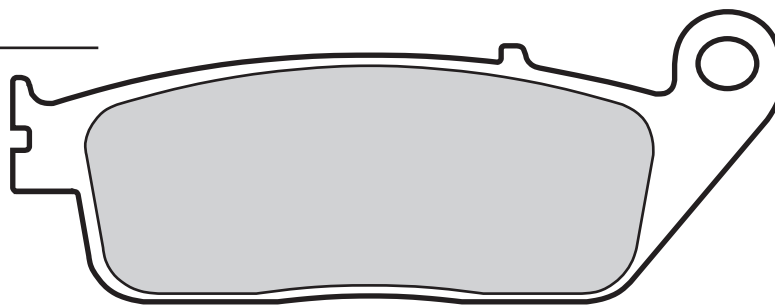

HONDA

250	VTR	98	•	-
400	CB SUPER FOUR	92	•	-
400	SILVERWING	06->	-	•
600	SILVERWING	00	-	•
600	SILVERWING ABS	03->	-	•

750	VF C	94	•	-
1100	ST ABS-TCS-CBS	92->95	-	•
1100	ST PAN EUROPEAN	90->02	-	•

KYMCO

250	VENOX	01	•	-
250	XCITING	05->	•	-

300	XCITING Ri	08->	•	-
500	XCITING	05->	•	-
500	XCITING AF1 ABS	06->	•	-

YAMAHA

300	VERSITY	05->	•	-
1670	MT-01	05	-	•
1700	MT-01	07->	-	•





07H03509 88.2 x 46.1 x 10.5
07H035SA 88.2 x 46.1 x 10.5
 Sintered

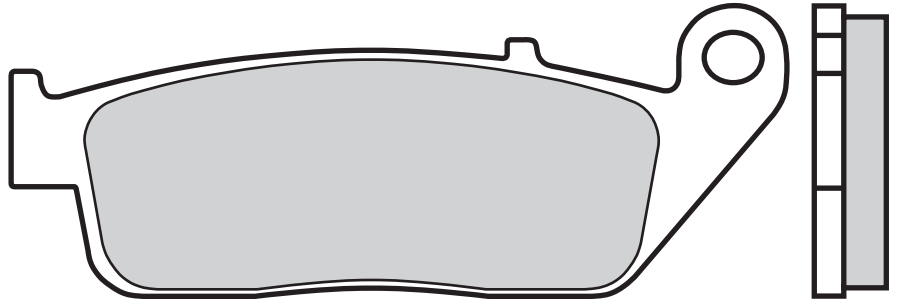

CAGIVA

500	CANYON	99	●	-
900	CANYON l.e.	97->98	●	-
900	ELEFANT l.e.	90	●	-



HONDA

125	CB TT	90	●	-
600	VT SHADOW, CUSTOM	88	●	-
600	VT C, SHADOW	92	●	-
600	XL V TRANSALP	91->93	●	-



650	NX DOMINATOR	88->92	●	-
650	XRV AFRICA TWIN	88	●	-
1500	GL GOLDWING SE	88->93	●	-
1500	GL ASPENCADE, SE	94->97	●	-
1500	GL GOLDWING SE	88	●	-
1500	GLX	88	●	-



07H03607 85.7 x 40.0 x 8.9
07H036SP 85.7 x 40.0 x 8.9
 Sintered

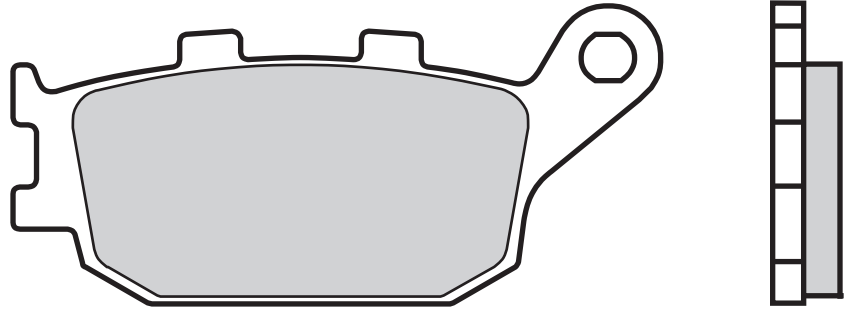

HONDA

400	CBR F	92	-	●
500	CBF	04->	-	●
500	CBF ABS	04->	-	●
600	CBF S	04->07	-	●
600	CBF	08->	-	●
600	CBF N	08->	-	●
600	CBF S	08->	-	●
600	CBR F, SUPER SPORT	91->94	-	●
600	CBR F3	95->98	-	●
600	CBR F4	99->02	-	●
600	CBR RR	03->04	-	●
600	CBR RR	05->06	-	●
600	HORNET	98->06	-	●
600	HORNET	07->	-	●
600	HORNET ABS	07->	-	●
650	NTV DEAUVILLE	01->02	-	●
700	XL TRANSALP	08->	-	●
750	CB N, SEVEN FIFTY	92	-	●
750	NR	92	-	●
900	CBR RR	92->97	-	●
900	CBR RR	98->99	-	●
900	CBR RR Fireblade (929 cc)	00->01	-	●



900	CBR RR Fireblade (954 cc)	02->03	-	●
900	HORNET	02	-	●
1000	CB BIG ONE	93->95	-	●
1000	CBF	06->	-	●
1000	CBF ABS	06->	-	●
1000	CBR RR	04->05	-	●
1000	VTR F FIRESTORM	97	-	●
1000	VTR SP01,SP02 (RC 51)	00	-	●
1100	VT SHADOW	94->96	-	●
1100	VT SHADOW C2	95->98	-	●
1100	VT SHADOW C3	99	-	●
1100	VT C2 Y	00	-	●
1300	STX PAN EUROPEAN	02	-	●
1300	VTX	03	-	●

KAWASAKI

750	Z 750	07->	-	●
750	Z 750 ABS	07->	-	●
1000	KLX	04->	-	●
1000	Z	07->	-	●

SUZUKI

650	GSF ABS	07->	-	●
650	GSF S ABS	07->	-	●



650	GSX F	08->	-	●
650	SV	03->04	-	●
650	V STROM	04	-	●
1000	DL V-STROM	02	-	●
1000	SV	03->	-	●
1000	SV S	03->	-	●
1250	GSF ABS	07->	-	●
1250	GSF S ABS	07->	-	●
1340	B-King	07->	-	●

YAMAHA

600	FZ 6	04->	-	●
600	FZ 6 FAZER	04->	-	●
600	FZ6 Fazer S2	07->	-	●
600	FZ6 Fazer S2 ABS	07->	-	●
600	FZ6 S2	07->	-	●
600	FZ6 S2 ABS	07->	-	●
600	YZF R6	03->	-	●
1000	FZ1	06	-	●
1000	FZ1 FAZER	06	-	●
1000	YZF R1	04->06	-	●
1000	YZF R1	07->	-	●
1000	YZF R1 SP	06	-	●





07H03907 125.5 x 44.3 x 8.7

07H039SA 125.5 x 44.3 x 8.7

Sintered

07H039SP 125.5 x 44.3 x 8.7

Sintered

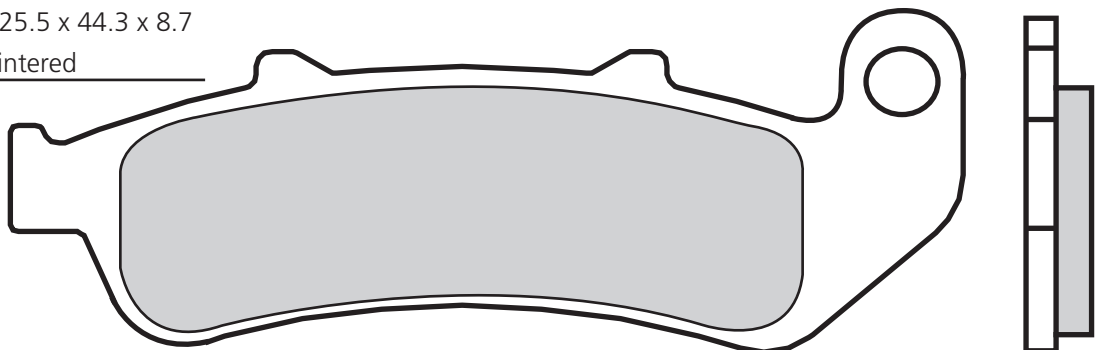

HONDA

1000	CBR F, FP	93->98	•	•
1100	ST ABS-TCS-CBS	92->95	•	-

3



07H04008 76.9 x 41.9 x 9,2

96.6 x 41.9 x 9,2

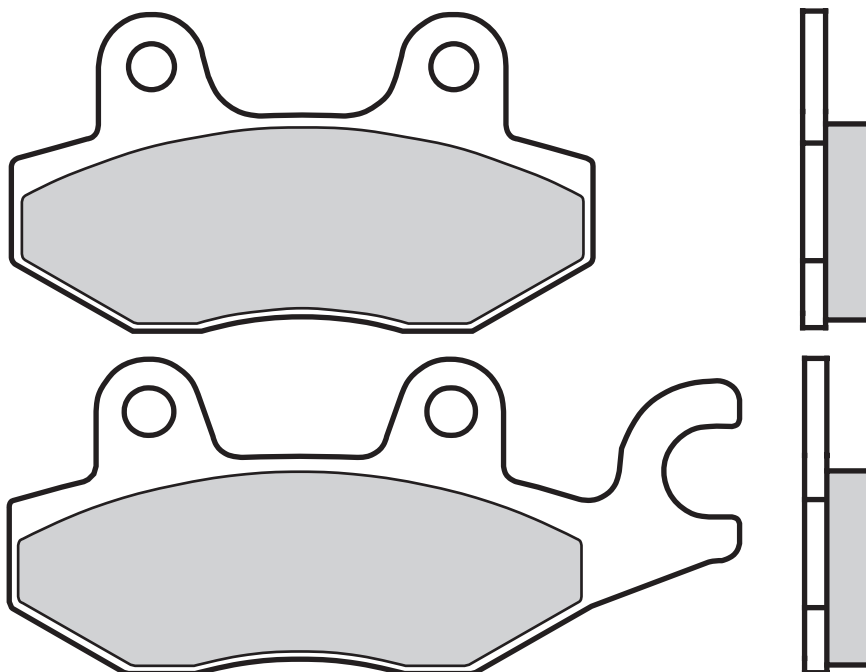

HONDA

125	VARADERO	01	•	-
125	VT SHADOW	99	•	-
150	NSR	02	•	-
250	CB F	04	•	-





07H04108 102.1 x 38.9 x 9.6

07H041SA 102.1 x 38.9 x 9.6

Sintered

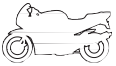
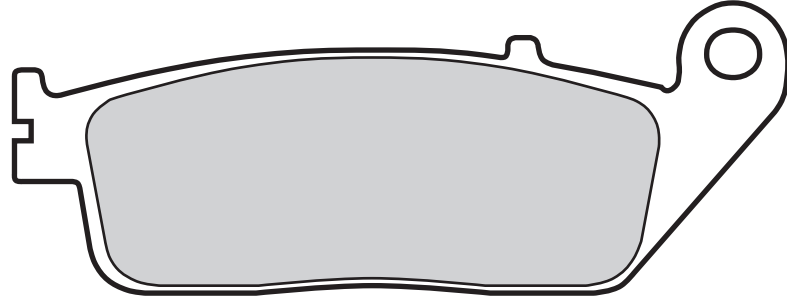
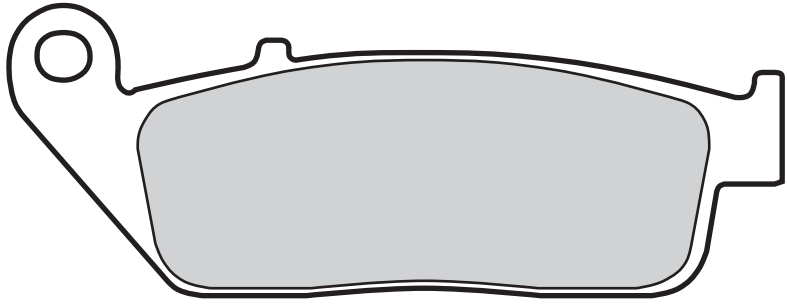

HONDA

500	CBF	04->	●	-
600	XL V TRANSALP	94->96	●	-
750	VT Shadow Spirit	07->	●	-



750	BLACK WIDOW	01	●	-
750	SHADOW	04	●	-
750	VT C, SHADOW	97->	●	-
1000	CBF	06->	●	-



TRIUMPH

900	ADVENTURER	95	●	-
900	THUNDERBIRD	95	●	-

3



07H04206 115.0 x 40.1 x 8.3

07H042SA 115.0 x 40.1 x 8.3

Sintered

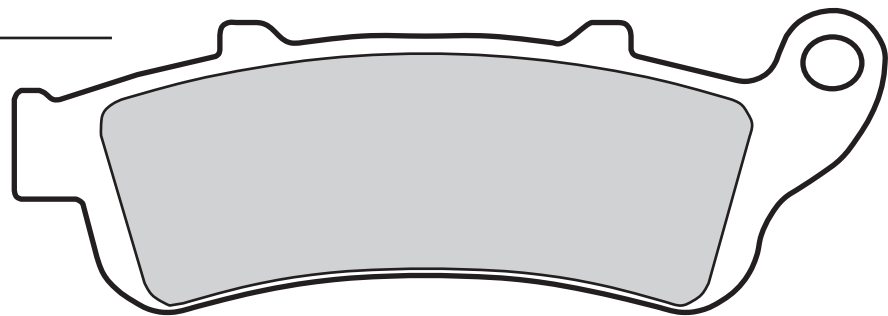

HONDA

250	FORESIGHT	97->	●	-
400	SILVER WING	06->	●	-
600	SILVER WING	00	●	-
600	SILVER WING ABS	03->	●	-
650	NTV DEAUVILLE	03	●	-
800	VFR FI	98->01	●	-



800	VFR V-TEC ABS	02->05	●	-
1000	CBR XX	96	●	-
1000	VARADERO ABS	04->	●	-
1000	XL VARADERO	99->03	●	-
1000	XL VARADERO (Linked Brake System)	00->	●	-
1100	CB HORNET	99	●	-



PEUGEOT

125	LOOXOR	02	●	-
-----	--------	----	---	---





07H04308 115.0 x 40.1 x 8.3

07H043SA 115.0 x 40.1 x 8.3
Sintered

07H043SP 115.0 x 40.1 x 8.3
Sintered

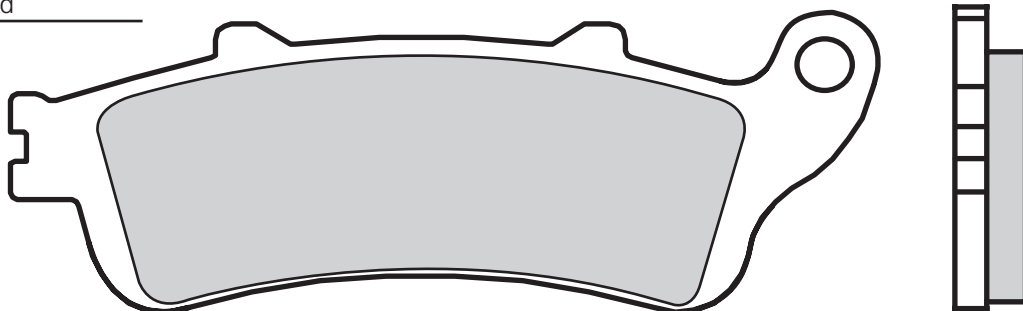

HONDA

1300	STX PAN EUROPEAN	02	•	-
650	NTV DEAUVILLE	03	-	•
700	NT DEAUVILLE ABS	06->	-	•
800	VFR FI	98->01	-	•
800	VFR V-TEC ABS	02->05	-	•

800	VFR V-TEC ABS	06->	-	•
1000	CBR XX	96	-	•
1000	VARADERO ABS	04->	-	•
1000	XL VARADERO	99->03	-	•
1000	XL VARADERO (Linked Brake System)	00->	-	•
1000	XLV VARADERO ABS	04->	-	•

1000	XLV VARADERO TRAVEL ABS	04->	-	•
1100	CB HORNET	99	-	•
1100	CB X-11	00	-	•
1100	ST	96	-	•
1300	VTX C	04	-	•
1800	GL GOLD WING	01	-	•
1800	VTX	01	-	•

3



07H04507 74.5 x 55.2 x 7.2

07H045RC 74.5 x 55.2 x 8.0

07H045SA 74.5 x 55.2 x 8.0
Sintered

07H045SC 74.5 x 55.2 x 8.0
Sintered

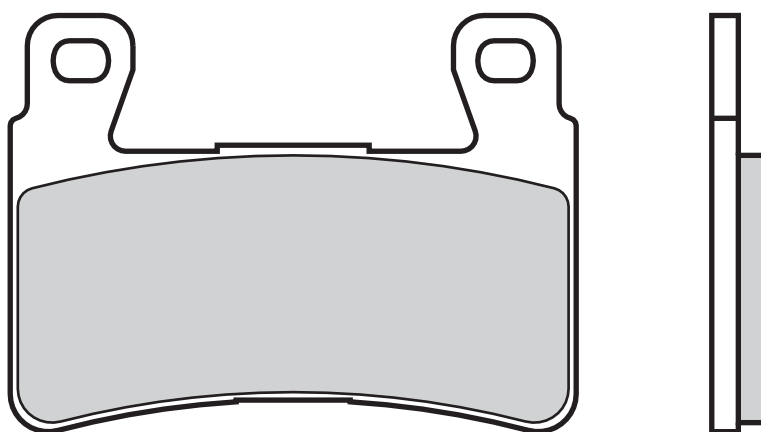

HONDA

600	CBR F4	99->02	•	-
600	CBR RR	03->04	•	-
900	CBR RR	98->99	•	-

900	CBR RR Fireblade (929 cc)	00->01	•	-
900	CBR RR Fireblade (954 cc)	02->03	•	-
1000	VTR SP01,SP02 (RC 51)	00	•	-
1300	CB	02	•	-





07HO4607 75.1 X 42.0 X 8.1

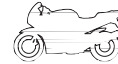
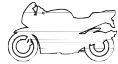
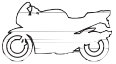
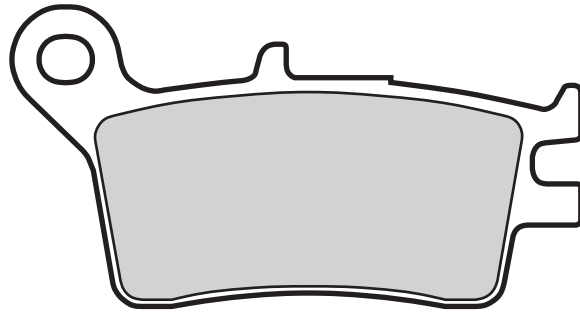

HONDA

220	TLM	89->	-	●
260	TLM R	90->	-	●



07HO48SD 59.7 x 43.7 x 9,5
Sintered

07HO48SX 59.7 x 43.7 x 9,5
Sintered

07HO48TT 59.7 x 43.7 x 9,5

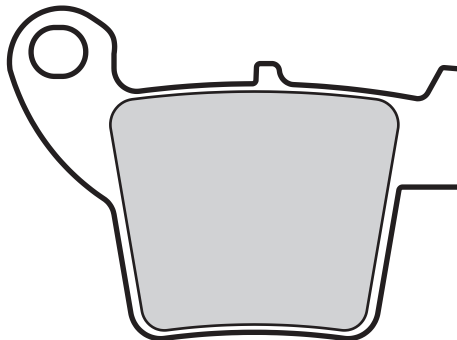

HM

125	CRE R ENDURO	02->	-	●
250	CRE F ENDURO	04->	-	●
250	CRE R ENDURO	02->	-	●
250	CRE X ENDURO	04->	-	●
250	CRF X SUPERMOTARD	04->	-	●
450	CRE F ENDURO	02->	-	●
450	CRE X ENDURO	04->	-	●
450	CRF F SUPERMOTARD	04->	-	●
450	CRF X SUPERMOTARD	04->	-	●

HONDA

125	CR R, E	02	-	●
150	CRF	07->	-	●
250	CR E	02	-	●
250	CR R	02	-	●
250	CRE F	04	-	●
250	CRE X	04	-	●

250	CRF R	04	-	●
450	CRE F	02	-	●
450	CRF, E	02	-	●
450	CRF X	05	-	●
450	TRX X	04	-	●





07H04905 106.7 x 42.4 x 10.0
91.4 x 39.8 x 10.0

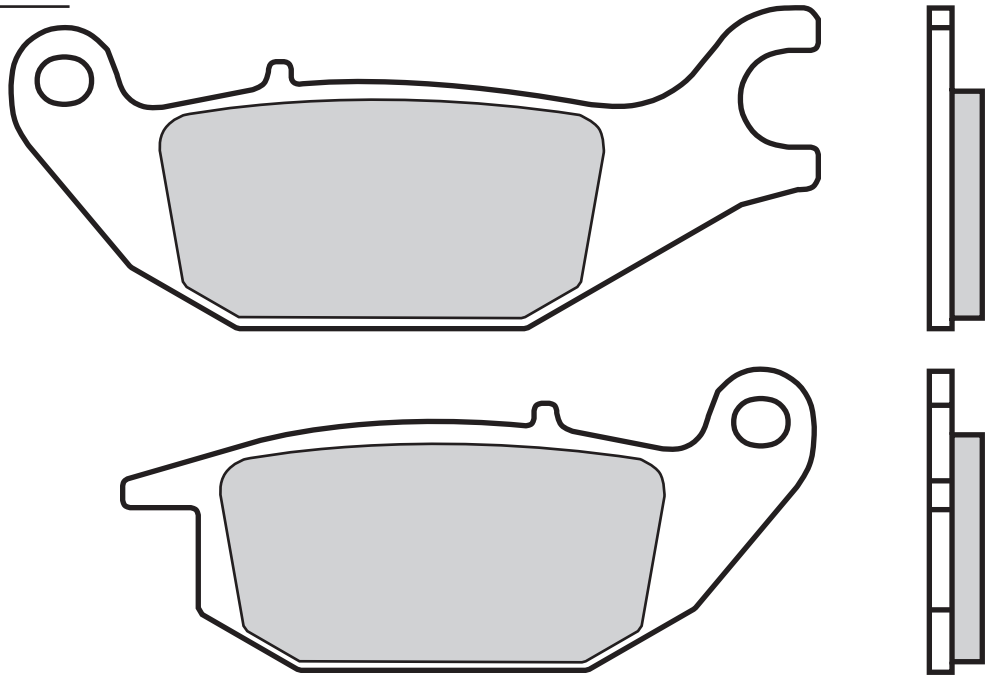

3

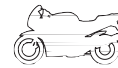

HONDA

125	CB S, S1, S2, S3	74->78	-	•
125	VARADERO	01	-	•
150	CBR R	00->	-	•



07H050RC 75.0 x 48.0 x 9.0
07H050SA 75.0 x 48.0 x 9.0
Sintered
07H050SC 75.0 x 48.0 x 9.0
Sintered

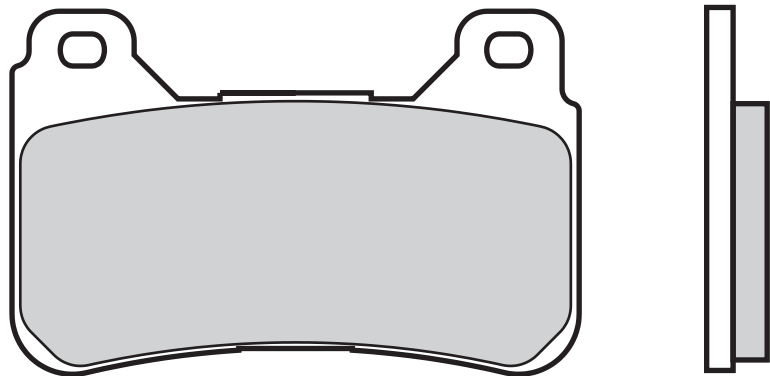

HONDA

600	CBR RR	05->06	•	-
600	CBR RR	07->	•	-

1000	CB R	08->	•	-
1000	CBR RR	04->05	•	-
1000	CBR RR	06->	•	-





07H05101 141.0 x 50.0 x 6.5

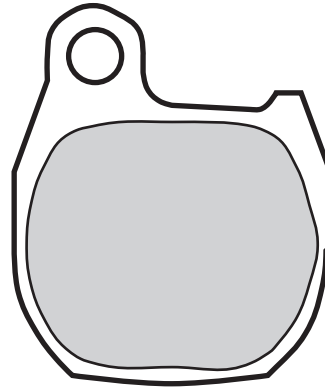

HONDA

220	TLM	89->	●	-
260	TLM R	90->	●	-



07H055SD 73,5 x 38,4 x 9.7
Sintered

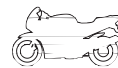
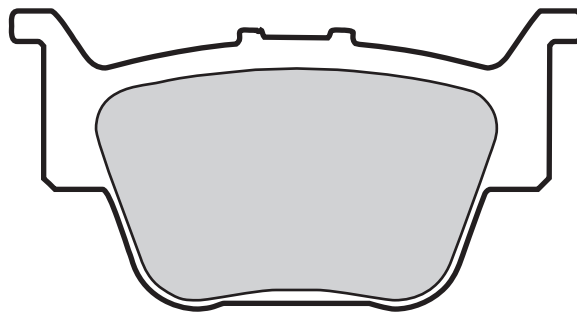

HONDA

450	TRX R	04->	●	-
650	TRX FA Rincon	03->05	-	●
650	TRX FGA Rincon	04->05	-	●
680	TRX FA6 Rincon	06->	-	●
680	TRX FGA6 Rincon	06->	-	●





07H05606 110.8 x 35.7 x 7.6
98.1 x 32.7 x 7.6

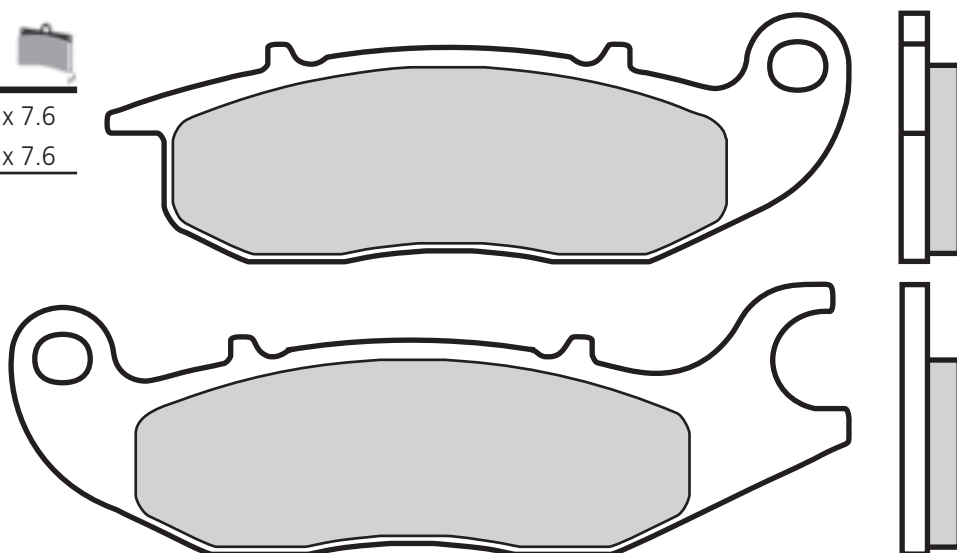

HONDA

125	ANF INNOVA	03->	•	-
125	CBR R	04->	•	-
150	CBR R	00->	•	-

RIEJU

50	RS2 NKD	06	•	-
125	RS2 NKD	06	•	-

3



07H057SA 117.6 x 44.9 x 8.8
Sintered

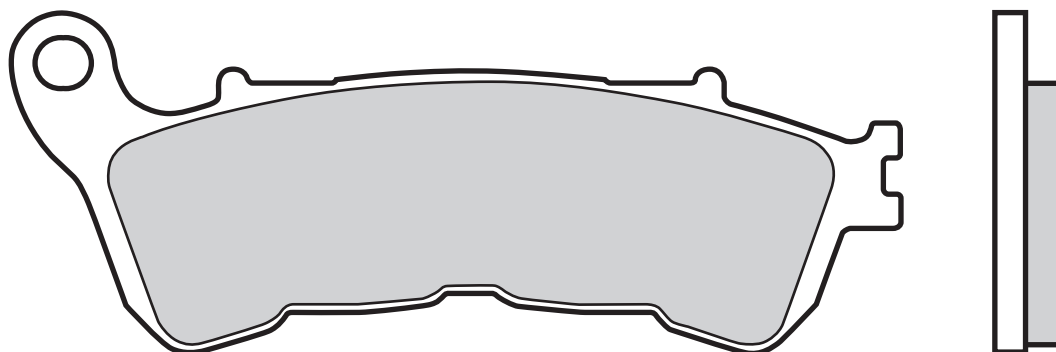

HONDA

500	CBF ABS	04->	•	-
600	CBF	08->	•	-
600	CBF N	08->	•	-
600	CBF S	08->	•	-
680	DN-01	08->	•	-
600	HORNET ABS	07->	•	-

700	NT DEAUVILLE ABS	06->	•	-
700	XL Transalp	08->	•	-
800	VFR V-TEC ABS	06->	•	-
1000	CBF ABS	06->	•	-
1000	XLV VARADERO ABS	04->	•	-
1000	XLV VARADERO TRAVEL ABS	04->	•	-

SUZUKI

1800	C R Intruder	08->	•	-
------	--------------	------	---	---





07H058SD 81.4 x 38.9 x 10.1
Sintered

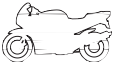
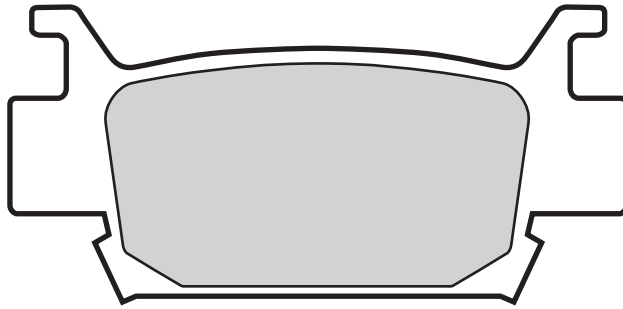

HONDA

500	TRX	05->	●	-
-----	-----	------	---	---



07H059SP 77.2 x 41.7 x 8.9
Sintered

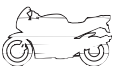
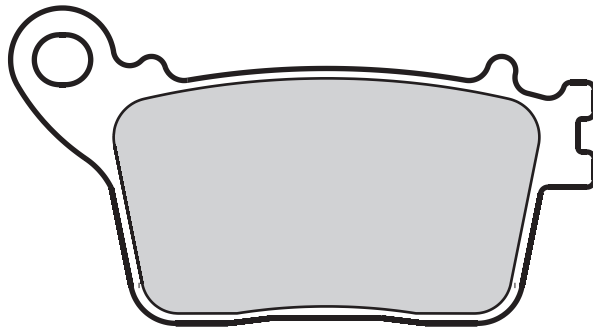

HONDA

600	CBR RR	07->	-	●
1000	CBR RR	06->	-	●

