

**07BB0306** 108.5 x 40.1 x 7.7

**07BB0310** 108.5 x 40.1 x 7.7

☉ Genuine Parts

**07BB0311** 108.5 x 40.1 x 7.7

☉ Genuine Parts

**07BB0350** 108.5 x 40.1 x 7.7

☉ Genuine Parts

Sintered

**07BB03SA** 108.5 x 40.1 x 7.7

Sintered



3

## APRILIA

650	MOTO	95	•	-
650	PEGASO	97->>03	•	-
650	PEGASO	04	•	-
650	PEGASO I.E.	01	•	-
650	PEGASO TRAIL	06->>	•	-
1000	ETV CAPO NORD	01->>03	•	-
1000	ETV CAPO NORD ABS	04	•	-
1000	ETV CAPO NORD RALLY RAID	04	•	-

## BMW

125	C1	99->01	•	-
125	C1 EXECUTIVE	00	•	-
125	C1 FRIENDS	01	•	-
200	C1	01	•	-
200	C1 EXECUTIVE	01	•	-
200	C1 FRIENDS	01	•	-
650	F 650, CS	02	•	-
650	F 650, ST	93->00	•	-
650	F 650 GS	01	•	-
650	F 650 GS DAKAR	01	•	-
650	G 650 Xchallenge	07->	•	-
650	G 650 Xcountry	07->	•	-
1200	HP2 ENDURO	06->	•	-

## DUCATI

992	GT 1000	07->	•	-
992	PAUL SMART 1000 L.E.	05->	•	-
992	SPORT 1000	05->06	•	-
992	SPORT 1000 (biposto)	07->	•	-
992	SPORT 1000 (monoposto)	07->	•	-
992	SPORT 1000 S	07->	•	-

## HONDA

500	CB	97	•	-
500	CB S	98	•	-
650	VIGOR	99->02	•	-
650	NTV DEAUVILLE	98->00	•	-
650	NTV DEAUVILLE	01->02	•	-
650	NX DOMINATOR	97	•	-

## KTM

640	ADVENTURE	06	•	-
640	ADVENTURE TRAVELLER'S EDITION	07->	•	-
640	LC4 ADVENTURE	05	•	-
690	Enduro	08->	•	-
690	Enduro	08->	•	-
950	ADVENTURE	03->	•	-
950	ADVENTURE S	03->	•	-
950	SUPER ENDURO	07->	•	-
950	SUPER ENDURO R	06	•	-
990	ADVENTURE	06->	•	-
990	ADVENTURE S	06->	•	-

## MOTO GUZZI

1100	CALIFORNIA CLASSIC, TOURING	06->	-	•
1100	CALIFORNIA EV	97->00	-	•
1100	CALIFORNIA EV	06->	-	•
1100	CALIFORNIA EV TOURING	04->	-	•
1100	CALIFORNIA EV, EV TOURING	03	-	•
1100	CALIFORNIA EV, SPORT	01->02	-	•
1100	CALIFORNIA JACKAL	99->01	-	•
1100	CALIFORNIA JACKAL BASIC	00	-	•
1100	CALIFORNIA JACKAL BASIC	01	-	•

1100	CALIFORNIA SPECIAL	99->00	-	•
1100	CALIFORNIA SPECIAL	01	-	•
1100	CALIFORNIA SPECIAL SPORT	02	-	•
1100	CALIFORNIA SPECIAL SPORT, SPECIAL ALLUMINIUM	02->	-	•
1100	CALIFORNIA STONE	01->05	-	•
1100	CALIFORNIA STONE, METAL	02->	-	•
1100	CALIFORNIA ALLUMINIUM, TITANIUM	03	-	•
1100	CALIFORNIA VINTAGE	07->	-	•
1100	QUOTA ES	99->01	•	-

## MOTO MORINI

1200	GRANPASSO	08->	•	-
------	-----------	------	---	---

## TM

125	ENDURO	05	•	-
125	MX	06	•	-
250	ENDURO	05	•	-
250	F	05	•	-
250	F ENDURO	05	•	-
250	MX	06	•	-
300	MX	05	•	-
250	MX	06	•	-
450	F	05	•	-
450	F ENDURO	05	•	-
530	F	05	•	-
530	F ENDURO	05	•	-

## TRIUMPH

2300	ROCKET III	04->	-	•
2300	ROCKET III CLASSIC	07->	-	•

## YAMAHA

125	DT X SUPERMOTARD	05	•	-
660	XT R	04->	•	->





**07BB0410** 94.0 x 36.2 x 7.5  
 Genuine Parts

**07BB0450** 94.0 x 36.2 x 7.5  
 Genuine Parts  
 Sintered

**07BB04SA** 94.0 x 36.2 x 8.0  
 Sintered

**07BB04SD** 94.0 x 36.2 x 8.0  
 Sintered

**07BB04SP** 94.0 x 36.2 x 8.0  
 Sintered

**07BB04SX** 94.0 x 36.2 x 8.0  
 Sintered

**07BB04TT** 94.0 x 36.2 x 8.0

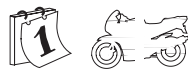
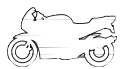
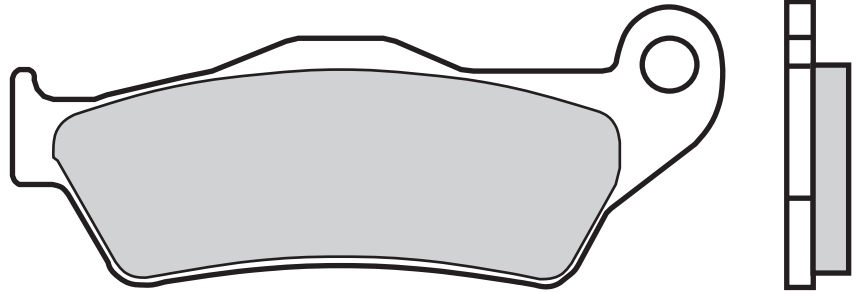

## ALFER

125 VRE	00	•	-
250 VR CROSS	99	•	-
250 VR ENDURO	99	•	-
250 VR SUPERMOTARD	99	•	-

## APRILIA

125 MX Supermoto	07->>	•	-
125 MX SUPERMOTARD	04	•	-
125 RX	96	•	-
125 RX ENDURO	08->>	•	-
125 RX SUPERMOTARD	08->	•	-
650 PEGASO	96	•	-
1000 RST FUTURA	01->04	-	•

## BENELLI

449 BX Cross	07->	•	-
505 ENDURO	08->	•	-

## BMW

450 ENDURO	08->	•	-
1200 HP2 ENDURO	06->	-	•
1200 HP2 Sport	08->	-	•

## CAGIVA

900 ELEFANT	93	•	•
-------------	----	---	---

## CCM

450 ENDURO	08->	•	-
600 SPORT	99	•	-
600 SUPERMOTO	99	•	-
600 RS	01	•	-
644 DS	02	•	-
644 R30	02	•	-

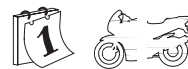

## DUCATI

620 MULTISTRADA 620 (Bidisco)	05	•	-
695 MONSTER 695	06->	•	-
803 MONSTER S2 R	05->	•	-
803 MONSTER S2 R DARK	05->	•	-

## GAS GAS

50 WILD HP	04->	•	•
125 EC	97->99	•	-
200 EC	99	•	-
240 WILD HP	04->	•	•
250 EC	97->99	•	-
250 MC	97->99	•	-
300 EC	99	•	-
300 WILD HP	03->	•	•
450 WILD HP	03->	•	•

## GILERA

500 NEXUS	03->05	•	-
500 NEXSUS (EURO 3)	06->	•	-
500 NEXSUS SP (EURO 3)	06->	•	-
800 GP 800	07->	•	-

## HIGHLAND

450 MX	06->	•	-
950 V2	99	•	-

## HONDA

650 SLR	97	•	-
---------	----	---	---

## HUSABERG

ALL MODELS	93	•	-
400 FC	99	•	-
400 FE	99	•	-

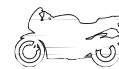

450 FC	03	•	-
450 FC (cross)	05->	•	-
450 FE	08->	•	-
450 FE E	04->	•	-
450 FE (enduro)	05->	•	-
450 FX	03	•	-
470 FC	01	•	-
470 FX	01	•	-
550 FC	01	•	-
550 FC (cross)	05->	•	-
550 FE E	04->	•	-
550 FE (enduro)	05->	•	-
600 FE, FC	99	•	-
650 FE (enduro)	05->	•	-
650 FX	01	•	-

## HUSQVARNA

125 CR	95->98	•	-
125 CR	99->02	•	-
125 CR	03->04	•	-
125 CR	05->	•	-
125 SM	98	•	-
125 SMS	00->01	•	-
125 SMS	05->	•	-
125 WR	95->97	•	-
125 WR	98->02	•	-
125 WR	03->04	•	-
125 WR	05->	•	-
125 WR E	94->98	•	-
125 WR E	98->05	•	-
125 WR E	06->	•	-
250 CR	95->98	•	-
250 CR	99->00	•	-
250 CR	01	•	-
250 CR	02->04	•	-



250 CR	05->	●	-
250 TC	02->03	●	-
250 TE	03	●	-
250 TE	04->	●	-
250 WR	95->97	●	-
250 WR	98->00	●	-
250 WR	01	●	-
250 WR	02->	●	-
350 TE	95	●	-
360 WR	95->98	●	-
360 WR	98->00	●	-
360 WR	01	●	-
360 WR	02	●	-
400 TE	01	●	-
410 TE	95->98	●	-
410 TE	99->00	●	-
410 TE E	00->01	●	-
450 TC	03	●	-
450 TC	04->	●	-
450 TE	03	●	-
450 TE	04->05	●	-
450 TE	06->	●	-
510 TE	06->	●	-
510 TE Centennial	04	●	-
510 TE R	04	●	-
570 TC	02	●	-
570 TE	01->04	●	-
610 TC	98	●	-
610 TC	99->00	●	-
610 TE	98	●	-
610 TE	99->00	●	-
610 TE E	00->01	●	-
610 TE E	03->04	●	-
610 TE E	98	●	-
610 TE E	99	●	-
610 TE E DUAL PURPOSE	06	●	-
610 TE E LT	99	●	-
510 TC	02->04	●	-
510 TC	05->	●	-
510 TE	05	●	-
610 TC	96->97	●	-
610 TE	96->97	●	-

## KRAMIT

250 GS, MX, SM	97	●	-
----------------	----	---	---

## KTM

125 EGS	93	●	-
125 EGS	94->97	●	-
125 EGS	98	●	-
125 EGS	99	●	-
125 EXC	93	●	-
125 EXC	94->97	●	-
125 EXC	98	●	-
125 EXC	99	●	-
125 EXC	00	●	-
125 EXC	01->03	●	-
125 EXC	04->	●	-
125 EXE	00->01	●	-

125 LC2	96->98	●	-
125 MX	92	●	-
125 GS	92	●	-
125 SUPERMOTO	00->01	●	-
125 SX	92->93	●	-
125 SX	94->97	●	-
125 SX	98	●	-
125 SX	99->00	●	-
125 SX	01->03	●	-
125 SX	04->	●	-
125 SXS	01->02	●	-
200 EGS	98	●	-
200 EGS	99	●	-
200 EXC	98	●	-
200 EXC	99->00	●	-
200 EXC	01->03	●	-
200 EXC	04->	●	-
200 MXC	98	●	-
200 MXC	99->00	●	-
200 MXC	01->03	●	-
200 SX	04	●	-
250 EGS	94->98	●	-
250 EGS	99	●	-
250 EXC	94->98	●	-
250 EXC	99->00	●	-
250 EXC	01->03	●	-
250 EXC	04->	●	-
250 EXC-F	06->	●	-
250 EXC RACING	03->04	●	-
250 EXC RACING	05->	●	-
250 MX	92	●	-
250 MXC	00	●	-
250 MXC	01	●	-
250 SX	92->93	●	-
250 SX	94->98	●	-
250 SX	99->00	●	-
250 SX	01->02	●	-
250 SX	03->	●	-
250 SX-F	06->	●	-
250 SXC	03	●	-
250 SXS	01	●	-
300 EGS	93	●	-
300 EGS	94->98	●	-
300 EGS	99	●	-
300 EXC	93	●	-
300 EXC	94->98	●	-
300 EXC	99->00	●	-
300 EXC	01->03	●	-
300 EXC	04->	●	-
300 MXC	97->98	●	-
300 MXC	99->00	●	-
300 MXC	01->03	●	-
300 SX	92->93	●	-
300 SX	94	●	-
300 SX	06->	●	-
350 EXC	94	●	-
350 EXC LC4	93->94	●	-
360 EGS	96->97	●	-
360 EXC	96->97	●	-

360 MXC	97	●	-
360 SX	96->97	●	-
380 EGS	98	●	-
380 EGS	99	●	-
380 EXC	00	●	-
380 EXC	01->02	●	-
380 EXC	98	●	-
380 EXC	99	●	-
380 MXC	00	●	-
380 MXC	01	●	-
380 MXC	98	●	-
380 MXC	99	●	-
380 SX	98	●	-
380 SX	99->00	●	-
380 SX	01->02	●	-
400 EGS	94->97	●	-
400 EXC	94->96	●	-
400 EXC	00	●	-
400 EXC	01->02	●	-
400 EXC RACING	05->	●	-
400 LC4	98->01	●	-
400 SUPERMOTO	01	●	-
400 SX	98	●	-
400 SX	99->00	●	-
400 SX	01->02	●	-
400 SXC	97	●	-
440 SX	94	●	-
450 EXC	03	●	-
450 EXC	04	●	-
450 EXC RACING	05->06	●	-
450 EXC RACING	07->	●	-
450 MXC	03	●	-
450 SX	03	●	-
450 SX	04	●	-
450 SX RACING	05->	●	-
450 SX-F	07->	●	-
500 MX	92	●	-
500 SX	92->93	●	-
505 SX-F	07->	●	-
520 EXC	00	●	-
520 EXC	01->02	●	-
520 MXC	01->02	●	-
520 SX	00	●	-
520 SX	01->02	●	-
525 EXC	03	●	-
525 EXC	04	●	-
525 EXC RACING	05->	●	-
525 MXC	03	●	-
525 SX	03	●	-
525 SX	04->	●	-
525 SX RACING	05	●	-
525 XC DESERT RACING	04->	●	-
530 EXC	08->	●	-
540 SXC	99	●	-
540 SXS	01->02	●	-
550 MXC	96	●	-
600 LC4	93	●	-
620 EGS	94->97	●	-



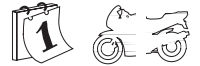
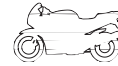
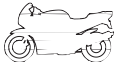

620	EGS ADVENTURE	97	●	-
620	EXC	94->	●	-
620	LC4	98->99	●	-
620	LC4 RALLY DAKAR	97	●	-
620	SC	01	●	-
620	SUPERMOTO	01	●	-
620	SX	94->97	●	-
620	SX	98	●	-
620	SX	99	●	-
620	SXC	97	●	-
625	SC	02	●	-
625	SUPERMOTO	02	●	-
625	SXC	03->	●	-
640	ADVENTURE	98->02	●	-
640	LC4	98->04	●	-
640	LC4 RALLY DAKAR	97	●	-
640	LC4	05	●	-
640	LC4 ADVENTURE	03->04	●	-
640	LC4 ENDURO	03->05	●	-
640	LC4 ENDURO	06->	●	-
640	LC4 SUPERMOTO	00->02	●	-
660	LC4 RALLY	99	●	-
660	LC4 RALLY	00->02	●	-
660	LC4 RALLY DAKAR	97	●	-
660	RALLYE FACTORY REPLICA	03	●	-
950	ADVENTURE	01->02	●	●
950	LC8 RALLYE	02	●	-
950	ADVENTURE S	03	●	-
950	ADVENTURE	03->	-	●
950	ADVENTURE S	03->	-	●
950	SUPERMOTO	05->	-	●
950	SUPERMOTO R	07->	-	●
950	SUPER ENDURO	07->	-	●
950	SUPER ENDURO R	06	-	●
990	ADVENTURE	06->	-	●
990	ADVENTURE S	06->	-	●
990	SUPERMOTO	06->	-	●

## MAICO

250	CROSS, ENDURO	99	●	-
500	CROSS, ENDURO	99	●	-
500	SUPERMOTARD	99	●	-

## MBK

125	SKYLINER	99->01	●	-
125	SKYLINER	02	●	-
125	THUNDER	01	●	-
150	SKYLINER	00	●	-
150	SKYLINER	01	●	-
150	THUNDER	02	●	-
180	SKYLINER	04	●	-
300	XC KILIBRE	03	●	●

## MOTO GUZZI

850	BREVA 850	06->	-	●
850	GRISO 850	06->	-	●
1100	BREVA	05->	-	●
1100	BREVA ABS	05->	-	●
1100	GRISO	05->	-	●

1100	QUOTA ES	99->01	-	●
1200	GRISO 8V	07->	-	●
1200	NORGE, ABS	06->	-	●
1200	SPORT	06->	-	●
1200	SPORT ABS	06->	-	●
1200	STELVIO	08->	-	●

## MOTO MORINI

1200	GRANPASSO	08->	-	●
------	-----------	------	---	---

## PIAGGIO

400	BEVERLY i.e.	06->	●	-
500	X9 EVOLUTION, ABS	04->	●	-

## RIEJU

450	MRX	08->	●	-
-----	-----	------	---	---

## SHERCO

250	2.5 i ENDURO	06	●	-
450	ENDURO	04	●	-
450	ENDURO	05	●	-
510	5.1 i ENDURO	06	●	-

## SUZUKI

125	BURGMAN	01->06	●	-
150	BURGMAN	04->	●	-

## TM

80	CROSS	96	●	-
85	85	01	●	-
125	125	96->00	●	-
125	125	01->04	●	-
125	ENDURO	01->04	●	-
250	E	95->00	●	-
250	E	01	●	-
250	E 4-stroke	00	●	-
250	E 4-stroke	01->04	●	-
250	250	01->04	●	-
250	250 4-stroke	01	●	-
300	300	98->00	●	-
300	300	01	●	-
300	E	01->04	●	-
320	320	96	●	-
400	4T	00	●	-
400	4T	01	●	-
400	E 4 stroke	01	●	-
450	4T	02->04	●	-
450	ENDURO 4 stroke	02->04	●	-
530	4T	01->04	●	-
530	E 4 stroke	01->04	●	-

## VERTEMATI

500	CROSS	02	●	-
501	ENDURO	02	●	-
501	SUPERMOTARD	02	●	-

## VOR

400	CROSS	00->01	●	-
400	EN	02	●	-

400	MX	02	●	-
450	EN	02	●	-
450	MX	02	●	-
500	ENDURO 492)	99	●	-
500	CROSS 495)	99	●	-
530	EN	02	●	-
530	MX	02	●	-

## YAMAHA

125	MAJESTY	98->00	●	-
125	MAJESTY	01->	●	-
125	MAXSTER	01->	●	-
150	MAJESTY	98->00	●	-
150	MAJESTY	01->	●	-
150	MAXSTER	01->	●	-
180	MAJESTY	03	●	-
180	MAJESTY	04->	●	-
300	VERSITY	03->04	●	●
300	VERSITY	05->	-	●
600	TT	93	●	-
600	TT 600	97	●	-
600	TT 600 R	97->	●	-
660	XT Z Ténéré	08->	●	-







**07BB0510** 34.9 x 40.5 x 7.5

☉ Genuine Parts  
Sintered

**07BB0551** 34.9 x 40.5 x 7.5

☉ Genuine Parts  
Sintered

**07BB05RC** 34.9 x 40.5 x 7.5

**07BB05SA** 34.9 x 40.5 x 7.5

Sintered

**07BB05SC** 34.9 x 40.5 x 7.5

Sintered

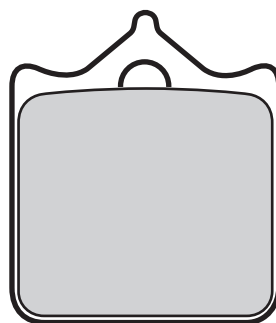

## APRILIA

1000 RSV FACTORY	04->>	●	-
1000 RSV NERA	04	●	-
1000 RSV R	01->03	●	-
1000 TUONO R	03->	●	-
1000 TUONO RACING	04	●	-

## BENELLI

449 BX SUPERMOTARD	08->	●	-
756 CUE	07->	●	-
900 TORNADO 3	03	●	-
1130 TNT SPORT	05->	●	-
1130 TNT CAFE' RACER	05->	●	-
1130 TNT TITATIUM	05->	●	-
1130 TORNADO TRE	06->	●	-

## BIMOTA

1000 DB5	05->	●	-
1000 DB6 DELIRIO	06->	●	-
1000 SB8 K SANTAMONICA	04->06	●	-
1098 DB7	08->	●	-
1100 DB6 R DELIRIO	08->	●	-

## CAGIVA

1000 X-RAPTOR	03	●	-
---------------	----	---	---

## DERBI

659 MULHACÉN	06->	●	-
659 MULHACÉN CAFE'	08->	●	-

## DUCATI

748 748 R	01->02	●	-
748 749	03->07	●	-
748 749 DARK	05->06	●	-
748 749 R	03->07	●	-
748 749 S	03->07	●	-
992 HYPERMOTARD HM10	06->	●	-
996 996 R	01	●	-
998 998 F.E.	04	●	-



998 998 R	02	●	-
998 998 S	02	●	-
998 999	03->07	●	-
998 999 R	03->07	●	-
998 999 S	03->07	●	-
998 999 XEROX	06	●	-
998 MONSTER S4 R Testastretta	07->	●	-
998 MONSTER S4 RS Testastretta	06->	●	-

## HUSQVARNA

250 SMR	06->	●	-
450 SMR	04->	●	-
450 SMR	06->	●	-
450 SMR R	06->	●	-
510 SM CENTENNIAL	06->	●	-
510 SMR	05->	●	-
510 SMR	06->	●	-
570 SMR	03->04	●	-
610 SM	05	●	-
610 SMS	06	●	-

## HYOSUNG

450 RX SM	08->	●	-
-----------	------	---	---

## KTM

690 DUKE	08->	●	-
690 SUPERMOTO PRESTIGE	07->	●	-
690 SMC	08->	●	-
950 DUKE	03	●	-
950 SUPERMOTO	05->	●	-
950 SUPERMOTO R	07->	●	-
990 SUPER DUKE	05	●	-
990 SUPER DUKE	06->	●	-
990 SUPER DUKE R	07->	●	-
990 SUPERMOTO	06->	●	-

## LAVERDA

1000 SFC 1000 (Limited Edition)	03	●	-
---------------------------------	----	---	---



## MONDIAL

1000 PIEGA	02	●	-
1000 PIEGA EVO	04	●	-
1000 STARFIGHTER RZ	04	●	-
1000 PIEGA RZ NUDA	04	●	-

## MOTO GUZZI

750 GRISO	04	●	-
1200 MGS-01 CORSA	05->	●	-

## MV AGUSTA

910 BRUTALE R	06->	●	-
1000 F4 R 312	07->	●	-
1000 F4 R, R 1+1	06->	●	-
1000 F4 SENNA	06->	●	-

## SHERCO

450 4.5 i SUPERMOTARD	06	●	-
-----------------------	----	---	---

## TM

450 SMX F	03	●	-
660 SMX F	05	●	-

## TRIUMPH

1050 SPEED TRIPLE	08->	●	-
-------------------	------	---	---





**07BB0606** 119.7 x 51.8 x 7.8

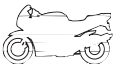
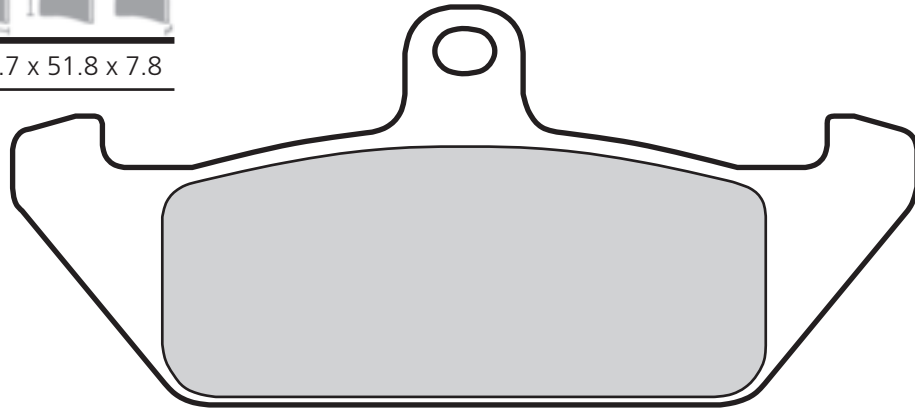

### APRILIA

600	TUAREG WIND	88->89	●	-
-----	-------------	--------	---	---

### CAGIVA

350	ELEFANT	85	●	-
650	ELEFANT	85->87	●	-
750	ELEFANT	87	●	-
750	ELEFANT	88->90	●	-
750	LUCKY EXPLORER	88	●	-



### DUCATI

650	INDIANA	86	●	-
750	INDIANA	89	●	-

### LAVERDA

600	ATLAS	86	●	-
-----	-------	----	---	---

### MOTO GUZZI

650	VT 65 TT BAJA	86	●	-
750	NTX	89	●	-

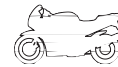

### MOTO MORINI

350	INDIANA	88	●	-
501	EXCALIBUR	86	●	●
501	EXCALIBUR	89->89	●	-
650	INDIANA	88	●	-
750	INDIANA	88	●	-



**07BB0708** 84.9 x 42.4 x 7.5  
55.8 x 37.0 x 9.8

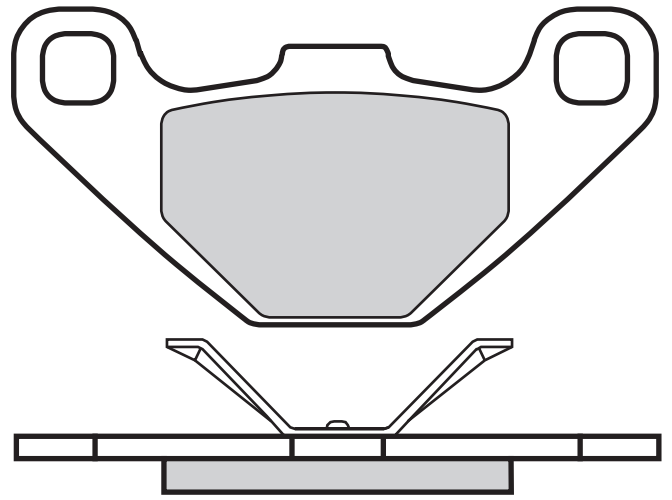
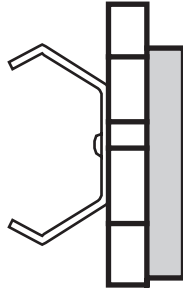
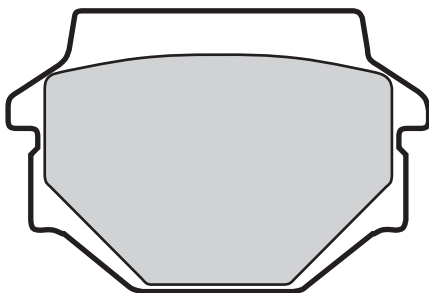

### APRILIA

125	MX Supermoto	07->	-	●
125	PEGASO	90->91	-	●
125	RX	91	-	●
125	RX	96	-	●



125	TUAREG WIND	90	-	●
350	TUAREG	88	-	●
350	TUAREG WIND	90	-	●
600	TUAREG WIND	90	●	●
600	TUAREG	88	-	●
650	MOTO	95	-	●

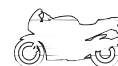

650	PEGASO	92->95	-	●
650	PEGASO	96	-	●
650	PEGASO	97->03	-	●

### CAGIVA

125	CROSS	88	-	●
-----	-------	----	---	---





125	WMX	89	-	●
125	W9	96	-	●
250	WMX	89	-	●
500	W16	94->98	-	●
600	W16	94	-	●

### FANTIC MOTOR

50	RAIDER	84	●	-
50	STRADA	83	●	-
125	STRADA	83	●	-

### HUSQVARNA

125	CR	91	-	●
125	WR	91	-	●
240	WR	91	-	●
250	CR, WR	91	-	●
260	WR	91	-	●
360	TE	95->98	-	●
510	CROSS COUNTRY LC	87	-	●



510	ENDURO LC	87	-	●
510	MOTOCROSS LC	87	-	●
510	TC MOTOCROSS	88	-	●
610	TC CROSS	91	-	●
610	TE	91->95	-	●

### KRAMIT

50	CRAMBLER		●	-
125	ER	89	-	●
250	ER, MC	89	-	●
300	ER	89	-	●

### KTM

125	EGS	93	-	●
125	EXC	93	-	●
125	GS	92	-	●
125	MX	89->91	●	●
125	MX	92	-	●
125	SX	92->93	-	●

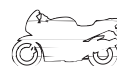

250	MX	89->91	●	●
250	MX	92	-	●
250	SX	92->93	-	●
300	EGS	93	-	●
300	EXC	93	-	●
300	SX	92->93	-	●
350	EXC LC4	93->94	-	●
500	MX	89->91	●	●
500	MX	92	-	●
500	SX	92->93	-	●
600	MX	91	●	●
600	LC4	93	-	●

### TM

400	CROSS	00	-	●
-----	-------	----	---	---

### YAMAHA

125	TDR ITALIA	90	-	●
-----	------------	----	---	---

3



**07BB0810** 45.2 x 52.5 x 6.3

Genuine Parts

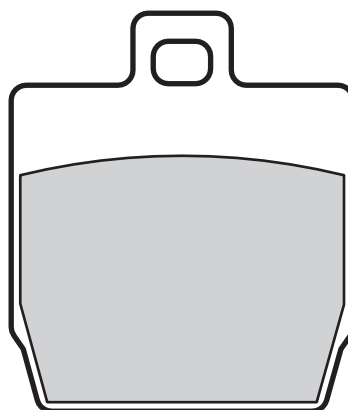

### MBK

50	NITRO	97	-	●
50	STUNT	00	●	-
100	NITRO	00	-	●



### YAMAHA

50	AEROX	97	-	●
50	SLIDER	00	●	-





07BB0907 99.9 x 46.8 x 8.5

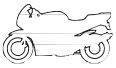
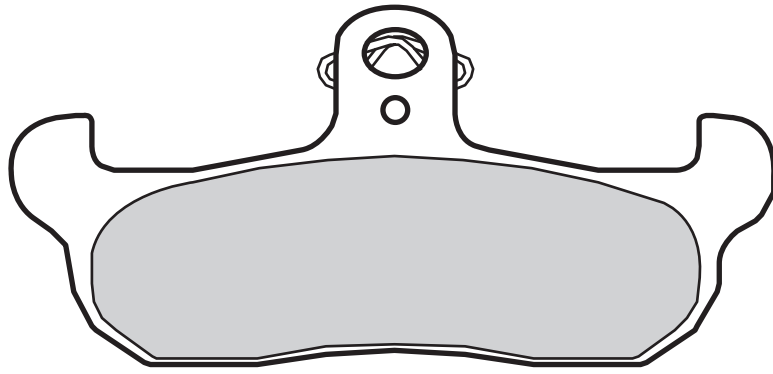

### APRILIA

125 AF1	86	●	-
125 RX	90	●	-
125 TUAREG RALLY	89	●	-
125 TUAREG WIND	88	●	-
350 RALLY	86	●	-

### CAGIVA

50 WMX	89	●	-
125 CROSS	88	●	-
125 CRUISER	87	●	-
125 FRECCIA C9	88	●	-
125 LUCKY EXPLORER	88	●	-
125 WMX	87->>88	●	-
125 WMX	89	●	-
250 WMX	87->88	●	-
250 WMX	89	●	-

### FRIGERIO PUCH

125 F7	89	●	-
250 REPLAY	89	●	-

### GILERA

125 RC TOP RALLY	89	●	-
600 RC	88	●	-



### HM

50 CRE	98	●	-
--------	----	---	---

### HONDA

50 CRE	93	●	-
--------	----	---	---

### HUSABERG

ALL MODELS	89->92	●	-
350 350	91	●	-
500 500	91	●	-
501 ENDURO		●	-
600 ENDURO		●	-

### HUSQVARNA

125 CR	91	●	-
125 WR	91	●	-
240 WR	87->90	●	-
240 WR	91	●	-
250 CR, WR	91	●	-
250 XC	87	●	-
250 WR	87	●	-
260 WR	91	●	-
360 TE	95->98	●	-
400 WR	87	●	-
430 CR	87	●	-
430 WR	87	●	-



430 XC	87	●	-
500 XC	87	●	-
510 CROSS COUNTRY LC	87	●	-
510 ENDURO LC	87	●	-
510 MOTOCROSS LC	87	●	-
510 TC MOTOCROSS	88	●	-
510 TE ENDURO	88	●	-
510 TX CROSS COUNTRY	88	●	-
610 TC CROSS	91	●	-
610 TE	91->95	●	-

### KRAMIT

125 ER	89	●	-
250 ER, MC	89	●	-
300 ER	89	●	-

### MOTO MORINI

400 DART	89->89	●	-
----------	--------	---	---

### TM

80 GS	87	●	-
80 MC	87	●	-
125 GS	87	●	-
400 CROSS	00	●	-

### YAMAHA

125 DT TENERE	89	●	-
125 TDR ITALIA	90	●	-

3





07BB1205 35.7 x 45.8 x 6.0

07BB12TT 35.7 x 45.8 x 6.0

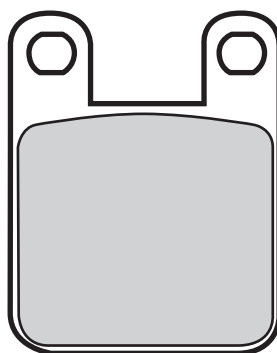

### ALFER

80	MC	87	-	●
250	VR NO LIMIT	99	-	●

### APRILIA

50	RS	06->>	-	●
50	RS, RS REPLICA	00	-	●
50	RX	08->	-	●
240	TX	86	●	-
250	AF1 REPLICA	90	-	●
280	280 R, CLIMBER	92	●	●
311	TX	86	●	●
312	TX, TXR	88->89	●	-

### BETA

	SR 34	89	●	-
50	REV	00->	●	●
50	RR ENDURO	99	-	●
50	RR STANDARD	99	-	●
50	RR SUPERMOTARD	99->03	-	●
50	RR SUPERMOTARD	04	●	●
50	ST	97	●	●
50	SUPER TRIAL	92	●	-
50	TECHNO	96	●	●
50	TEMPO	92->96	●	-
80	REV	06->>	●	●
125	ALP	99	●	●
125	TR	97	●	-
125	TR34, TR35	88->90	●	●
125	TRIAL	97	●	-
200	ALP	00	●	●
240	ALP	92->95	●	-
240	ALP	96	●	-
240	SUPER TRIAL	92	●	-
250	ALP	97	●	●
250	ALP	92->96	●	-
250	EIKON	99	●	●
250	TECHNO	96->	●	●
250	ZERO	91	●	-
260	ALP	96	●	-
260	TR34, TR35	89->92	●	-
260	ZERO	91	●	-

### BULTACO

50	ASTRO	01	-	●
----	-------	----	---	---



50	LOBITO	99	-	●
----	--------	----	---	---

### CAGIVA

50	CORSA	98	●	-
50	MANTIS	98	●	-
50	MITO	99	-	●
50	PROGRESS	98	●	-

### DAELIM

50	HISTORY	01	●	-
50	VARIANT SPORT - R	01->	●	-

### DERBI

50	ATLANTIS	99->	●	-
50	ATLANTIS 4-stroke	04->	●	-
50	ATLANTIS BULLET	04->	●	-
50	ATLANTIS CITY	06->	●	-
50	ATLANTIS H2O	01	●	-
50	ATLANTIS H2O WAVE	01	●	-
50	ATLANTIS TO CHIC	05->	●	●
50	ATLANTIS WAVE	01	●	-
50	AVENTURA	96	●	-
50	BLACK DEVIL	04	-	●
50	DRD PRO R	06->	-	●
50	DRD RACING R	05->	-	●
50	DRD RACING R Limited edition	05->	-	●
50	DRD RACING SM	05->	-	●
50	DRD RACING SM Limited edition	05->	-	●
50	DS	88	●	-
50	FDX	89	●	-
50	FENIX	94	●	●
50	FURAX	96	●	●
50	GP	01	●	-
50	GP1	05->	-	●
50	GP1	01->04	●	●
50	GPR	98	-	●
50	GPR NUDE	04->	-	●
50	GPR RACING	04->	-	●
50	GPX1	06->	-	●
50	HUNTER	96->97	●	-
50	MANHATTAN	99	●	●
50	PADDOCK	97	●	-
50	PREDATOR	97->00	●	●
50	RAMBLA	06->	●	●



50	SAVANNAH	91	●	-
50	SEND A R	03->04	-	●
50	SEND A R	94->99	●	●
50	SEND A SM	99->02	●	●
50	SEND A SM DRD	03->04	●	●
50	SEND A SM DRD BLACK ED.	03->	-	●
50	STINGER	96	●	-
50	VAMOS (AJP caliper)	95->97	●	-
50	VARIANT SPORT - R	01	●	-
50	X-RACE R	05->	●	●
50	X-TREME R	05->	●	●
75	GPR	89	-	●
80	GPR CUP	04->	-	●
100	ATLANTIS 4-stroke	04->	●	-
100	ATLANTIS H2O	01	●	-
125	BOULEVARD	04->	●	-
125	GP1	05->	-	●
125	GPR	05->	-	●
125	GPR NUDE	05->	-	●
125	SEND A 4-stroke	04->	-	●
125	SEND A R 4-stroke	05->	-	●
125	SEND A X-TREME SM	04->	-	●
125	Terra	07->	●	●
150	BOULEVARD	04->	●	-
200	BOULEVARD	06->	●	-
250	GP1	05->	-	●

### FANTIC MOTOR

50	CLUBMANN	94	●	-
50	TRIAL	89	●	-
250	K-ROO	91	-	●
250	TRIAL	91	-	●
305	TRIAL	88	-	●
307	TRIAL	91	●	●

### GARELLI

50	CICLONE LC, SM	86	●	-
50	SAHEL	91	-	●
323	TRIAL	86	●	-

### GAS GAS

50	TXT BOY	04	●	●
125	DELTA	91	●	-
125	PAMPERA	96->03	●	●
200	PAMPERA	99->	●	●



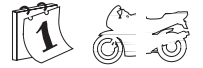
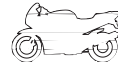
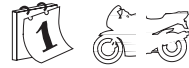
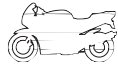
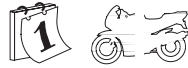
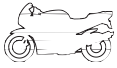

200	TX	97->	●	●
250	PAMPERA	96->99	●	●
250	TRIAL	89	●	●
270	TX	97	●	●
320	TX	97->	●	●
370	PAMPERA	96->	●	●

## GILERA

50	HAK	99	●	●
50	RCR	04	●	●
50	SMT	04	●	●
50	SUPERMOTARD	01	●	●
50	ZULU	01	●	●
125	GSM	00	●	●
125	SC	06->	-	●
125	SURFER	00	●	●

## HRD

50	SONIC	00	-	●
50	SONIC TRIAL	00	-	●
125	SUPERMOTARD	00	-	●
125	TRIAL	00	-	●

## HUSQVARNA

50	HUSKY BOY	01	●	-
50	RACING	98	●	-
50	SM	02	-	●
50	WR	02	-	●
50	WRS	98	●	-

## HYOSUNG

50	WRS	98	●	-
----	-----	----	---	---

## ITALJET

50	DRAGSTER	97->98	●	●
50	FORMULA AIR	99	●	-
50	FORMULA LC	98	●	●
50	JET SET	02->	●	-
50	NEW TORPEDO	00	●	-
50	TORPEDO	97	●	-
50	TORPEDO 4T	01	●	-
125	DRAGSTER (AJP cal.)	97	●	●
125	FORMULA (AJP cal.)	95	●	●
125	JET SET	02	●	-
125	JUPITER	02	-	●
125	TORPEDO 4T	99	●	-
125	TWIN	98	●	●
150	JET SET	02	●	-
150	JUPITER	02	-	●
150	TORPEDO 4T	99	●	-
180	DRAGSTER (AJP cal.)	99	●	●

## KTM

50	SX	99	●	-
65	SX	00->01	●	-

## MACAL

50	TROPHY	99	●	-
----	--------	----	---	---

## MALAGUTI

50	DRAKON	05->	-	●
50	FIFTY	04	-	●
50	NKD	04	-	●
50	NKD DRAGON	06->	-	●
50	XSM	03->	-	●

## MBK

50	X LIMIT	04	●	●
50	X POWER	04	-	●

## MONTESA

125	COTA	88	●	●
125	COTA	88	●	●
260	EVASION	92	●	-
304	COTA	88	●	●
307	COTA	89	●	●
307	COTA TRIAL	88	●	●
309	COTA	89	●	-
310	COTA	89	●	-
311	COTA TRIAL	92	●	-
315	COTA R	97	●	●
335	COTA	87->91	●	●
360	ENDURO	85	●	-

## MORBIDELLI MBA

125	JR	76	●	●
-----	----	----	---	---

## PEUGEOT

50	BUXY R (AJP caliper)	93->97	●	-
50	ELYSEO (AJP caliper)	99->01	●	●
50	ELYSTAR	03	●	-
50	ET FORCE	03	●	●
50	ET FORCE C-TECH	05	●	●
50	LOOXOR	02	●	-
50	LUDIX	04	●	-
50	LUDIX BLASTER	05	●	-
50	METAL X	01	●	-
50	SPEEDAKE (AJP cal.)	95->97	●	-
50	SPEEDFIGHT (AJP cal.)	00	●	●
50	SPEEDFIGHT (AJP cal.)	99	●	-
50	SQUAB (AJP caliper)	96	●	-
50	TKR	96	●	-
50	TKR FURIOUS	05	●	-
50	TKR STREET ZONE	03	●	-
50	TKR WRC	05	●	-
50	TREKKER	99	●	-
50	TREKKER STREETBOARD	00	●	-
50	TREKKER URBAN BLACK	00	●	-
50	TSDI	04	●	●
50	VIVACITY	99	●	-
50	VIVACITY COMPACT	03	●	-
50	VIVACITY X RACE	03	●	-
50	XP6 ENDURO	06->	●	●
50	XP6 SUPERMOTARD	06->	●	●
50	XP6 TRIAL	04	●	●
50	XP56 ENDURO	02	●	●
50	XP56 SUPERMOTARD	04	-	●

50	XR6	02	-	●
50	ZENITH LN/LS	97	●	-
100	ELYSEO	00	●	●
100	ELYSEO (AJP caliper)	98->99	●	-
100	LOOXOR	02	-	●
100	SPEEDFIGHT (AJP cal.)	98	●	●
100	SPEEDFIGHT 2 206 WRC	03	●	●
100	SPEEDFIGHT 2 FURIORS	03	●	●
100	TREKKER	99	●	●
100	VIVACITY	99	●	-
100	X-FIGHT	00	●	●
125	ELYSEO	98->99	●	-
125	ELYSEO	00	-	●
125	LOOXOR	02	-	●
125	LUDIX	04	●	-
125	SATELIS	04->05	●	-
125	XPS CT	06	●	●
150	LOOXOR	06	●	-

## PIAGGIO

50	DIESIS	02	●	-
100	DIESIS	02	●	-

## PUCH

50	TZX	92	●	-
75	COBRA	85	●	-

## RIEJU

50	DRAC	97	●	●
50	EVOLUTION RS1	96->00	●	●
50	FD4 SUPER MARATHON	85	●	-
50	FISRT	97	●	-
50	MATRIX	03	-	●
50	MRX	02->04	●	●
50	MRX PRO	05	-	●
50	MX (AJP caliper)	02	●	●
50	NKD	04	-	●
50	RACING	01	-	●
50	RR SUPERMOTARD	96	●	●
50	RRX	08->	●	●
50	RRX SPIKE	08->	●	●
50	RS1	92	●	●
50	RS1	01	-	●
50	RS1 CASTROL	01	-	●
50	RS2 MATRIX	03	-	●
50	SMX PRO	08->	-	●
50	SMX	02	-	●
50	SPIKE	02	-	●
50	SPIKE (AJP caliper)	02	-	●
50	TANGO	08->	-	●
50	WINDY	97	●	-
80	CROSS, ENDURO	87	●	●
80	RST	91	●	●
125	MRX	03	-	●
125	MRX (AJP caliper)	03	●	●
125	RR	97	●	●
125	SMX	03	-	●
125	SMX (AJP caliper)	03	●	●
125	TANGO	06->07	-	●





125	TANGO	08->	-	•
125	TANGO PRO	08->	-	•

## SACHS

50	MADASS	05	-	•
----	--------	----	---	---

## SCORPA

115	TY-S F TRIAL	06	•	-
-----	--------------	----	---	---

## SHERCO

50	Enduro	07->	-	•
50	SM, ENDURO	02	-	•
50	Supermotard	07->	-	•
80	80	01	•	•



125	125	01	•	•
125	125	02	-	•
125	CITY CORP 4T ENDURO	03	-	•
125	CITY CORP 4T SM	03	-	•
200	200	01	•	•
250	250	99->00	•	•

## SIMSON

125	SM	01	-	•
125	STAR	99	•	-

## SUZUKI

50	DR BIG	89	•	-
50	KATANA -AY	97	•	-



50	KATANA LC	97	-	•
50	KATANA RX	98	-	•
50	RMX	00	•	•
50	SMX SUPERMOTARD	00	•	•
50	UF ESTELETE	00	•	-
50	UX ZILLION	99	•	-
50	W, WR	00	-	•

## YAMAHA

50	DT R	04	•	-
50	TZR	03	-	•
125	XT R	05	•	•
125	XT X SUPERMOTARD	05	-	•
250	TY R	91->92	•	-
250	TY Z	93	•	•

3



**07BB1305** 35.3 x 51.4 x 6.3

**07BB1310** 35.3 x 51.4 x 6.3

Genuine Parts

**07BB13SD** 35.3 x 51.4 x 6.3

Sintered

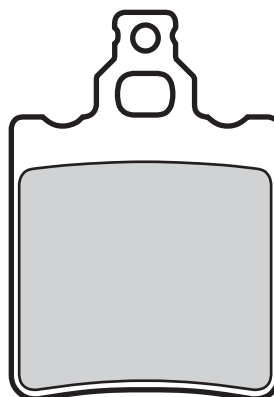

## APRILIA

50	AF-1	86	-	•
50	AF-1 FUTURA, EUROPA	90	-	•
50	ET TUAREG	86	-	•
50	MX	03	-	•
50	PEGASO		-	•
50	REPLICA	92	-	•
50	RS	96->99	-	•
50	RS REPLICA	03->05	-	•
50	RX	90->91	-	•
50	RX	92	-	•
50	RX RACING	04->07	-	•
50	TUAREG	86	-	•
50	TUAREG RALLY	90	-	•
125	TUAREG WIND	88	-	•
240	CLIMBER	89->90	-	•
275	275 CLIMBER	89->90	-	•

## BENELLI

125	BXK	88	-	•
-----	-----	----	---	---



## BETA

350	4.0 MOTARD	04	-	•
350	ALP 4.0	04->05	-	•

## CAGIVA

125	ALETTA ORO	85->86	•	•
125	ALETTA ROSSA	83	•	-
125	E2	86	•	-
125	ELECTRA,ELEFANT	83->86	•	-
125	SPORT	85	•	•
125	SXT, SST	81	•	-
200	ALETTA ELECTRA	83	•	-
200	CROSS	83	•	-
50	BLUES	89	-	•
50	COCIS	89	-	•
50	LUCKY EXPLORER	88	-	•
50	W4	92	-	•
80	COCIS	91	-	•
125	CRUISER	87	-	•
125	DAKAR	89->90	-	•



125	LUCKY EXPLORER	88	-	•
125	N 90	90	-	•
125	TAMANACO	89	-	•
125	W8	92->98	-	•

## FANTIC MOTOR

50	KOALA	88->95	•	•
50	K-ROO	91	•	-
50	OASIS	88->89	•	•
125	K-ROO	91	•	-
125	RAIDER LC	83->84	•	-
250	K-ROO	91	•	-
305	TRIAL	88	•	-
250	TRIAL	91	•	-
50	CABALLERO RS / RC	90	-	•
50	OASIS	90	-	•
50	RC CABALLERO RS	91	-	•
75	OASIS	89	-	•

## FRIGERIO PUCH

125	CROSS	84->85	•	-
-----	-------	--------	---	---





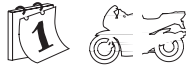
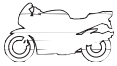

125	REPLAY	89	-	•
-----	--------	----	---	---

## GARELLI

125	STRADA GTA	83->85	•	•
125	STRADA, SPORT	84->85	•	-
125	TIGER XLE	86	-	•

## GILERA

250	NGR	85	•	-
125	X1	89->89	-	•

## HRD

125	SILVER HORSE	85	•	•
-----	--------------	----	---	---

## LAVERDA

125	125	84	•	-
-----	-----	----	---	---

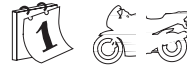

125	CUSTOM	86	•	•
125	GS LESMO	86	•	•
125	LB (CU/SP)	84	•	-
125	LB SPORT	84	•	-
125	LB STRADA	85	•	-
125	LESMO	86	•	•
125	LS STRADA	85	•	-
125	NAVARRO	90	•	•
125	TOLEDO	90	•	•
150	FORMULA	86	•	-

## MALAGUTI

50	DUNE ES	89	•	•
50	EVOLUTION	91	•	-
50	MDX	86	•	-
50	RST SPORT	88	•	•

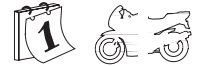
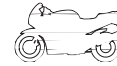

50	XTM	03->	•	•
----	-----	------	---	---

## MALANCA

80	GTI		•	•
125	OB ONE M6	85	•	•
125	GTI	80	•	•
125	MARK ENDURO	85	•	-
125	SPORT	78	•	•

## ZÜNDAPP

80	KS SUPER	80	•	-
80	KS SUPER	82	•	-



**07BB1408** 55.6 x 53.6 x 9.0

**07BB1410** 55.6 x 53.6 x 9.0

☉ Genuine Parts

**07BB14SP** 55.6 x 53.6 x 9.0

Sintered

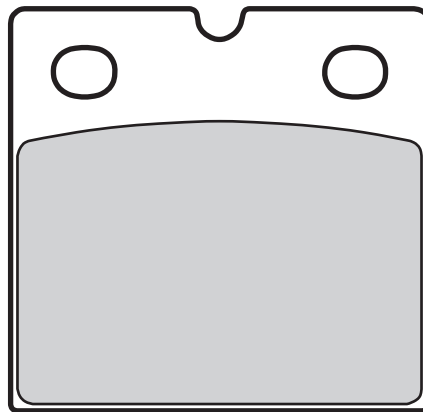

3



## BENELLI

750	SEI	75	•	-
900	SEI	78	•	-
350	354 TURISMO, SPORT	83	-	•
500	504 SPORT	76	-	•
650	654	83	-	•
650	654 SPORT	83	-	•

## BIMOTA

	HB 2	80	•	•
	HB 3	82	•	•
	KB 1/A	78	•	•
	KB 2/S	81	•	•
	KB 2	81	•	•
	KB 3	82	•	•
	SB 3	80	•	•
	SB 4	82	•	•
1000	DB 1	87	•	-



1200	YB 5 FS	87	•	-
------	---------	----	---	---

## BMW

450	R 45	81	•	-
650	R 65	81	•	-
650	R 65 LS	82	•	-
750	K 75 RT	91	-	•
750	K 75, K 75C, K 75T	84	•	-
750	K 75S	83	•	•
800	R 80	81	•	-
800	R 80 GS	81->87	•	-
800	R 80/7	79->81	-	•
1000	K 1	89	-	•
1000	K 100	83	•	•
1000	K 100 ABS (special caliper)	91	-	•
1000	K 100 LT	87->91	•	•
1000	K 100 LT	92	-	•
1000	K 100 RS	83	•	•



1000	K 100 RS 16V.	90	-	•
1000	K 100 RT	84	•	•
1000	R 100 CS	81->83	-	•
1000	R 100 CS	84	•	•
1000	R 100 R	91	-	•
1000	R 100 RS	76->80	-	•
1000	R 100 RS	81->83	-	•
1000	R 100 RS	84	•	•
1000	R 100 RT	79->80	-	•
1000	R 100 RT	81->83	-	•
1000	R 100 RT	84	•	•
1000	R 100 S	78->80	-	•
1000	R 100 T	79	-	•
1100	K 1100 LT	92	-	•
1100	K 1100 RS	93	-	•
1100	R 1100 RS	93	-	•
1200	K 1200 GT ABS	02->	-	•
1200	K 1200 RS	97->00	-	•
1200	K 1200 RS	01	-	•





## CAGIVA

500 RIVER	99	●	-
-----------	----	---	---

## DUCATI

600 PANTAH	81	●	-
650 SL	84	●	-
750 LAGUNA SECA	87	-	●
750 PASO	87->88	●	-
750 SANTAMONICA	87	●	●
750 SPORT	74->76	●	-
750 SPORT	88	●	●
900	85	●	●
900 MIKE HAILWOOD Replica	85	●	●
900 REPLICIA	85	●	●
900 SUPERSPORT 900	81	●	●
900 S2	82	●	●
906 PASO	89	●	●
906 SANTAMONICA	87	●	●
1000 MIKE HAILWOOD Replica	85	●	●
1000 R1	84	●	●
1000 S2 DESMO	85	●	●

## HOREX

125 IMPERATOR	96	●	-
125 REGENT	96	●	-
560 560 E	86	●	-
600 COLUMBUS	87	●	-

## HRD

600 600 (HOREX)	85	●	●
-----------------	----	---	---

## LAVERDA

650 SFC	86	●	●
650 V-SIX	93	●	●
750 SF3	74->78	●	-
1000 1000	73	●	-
1000 EXECUTIVE	84	●	●

1000 JOTA	84	●	●
1000 RGS 1000	82->83	●	●
1000 SFC	86	●	●
1200 MIRAGE	78	●	●

## MOTO GUZZI

350 NTX	90	-	●
750 NTX	90	-	●
750 S3	75->76	●	-
750 SP	91	●	●
750 V75	86	●	●
850 850 LE MANS	76->80	●	-
850 850 LE MANS III	81->84	●	●
850 850 LE MANS T4 (Germany)	85	●	●
850 850 T3	75	●	●
850 850 T3 GERMANIA	75	●	-
850 850 T3 CALIFORNIA	76	●	-
850 850 T3 CARABINIERI, POLIZIA	83	●	●
850 850 T4	83	●	●
850 850 T5	85->88	●	●
1000 CALIFORNIA II	83->86	●	-
1000 CALIFORNIA III	87->93	●	●
1000 GS CONVERT	75	●	●
1000 GS CONVERT GERMANIA	75	●	-
1000 GT 1000	87->91	●	●
1000 LE MANS IV	85->89	●	●
1000 S 1000	89->94	●	●
1000 SP 1000	78	●	-
1000 SP 1000 II	83->88	●	●
1000 SP 1000 III	89->94	●	●
1000 STRADA	93->94	●	●
1000 V	93	●	-
1000 V CALIFORNIA		●	●
1000 V I CONVERT		●	-
1100 CALIFORNIA	94->97	●	●
1100 SPORT	01	-	●

## MZ

125 ETZ	82	●	-
125 ROADSTAR		●	-
125 SPORTSTAR	93	●	-
150 ETZ	82	●	-
250 ETZ	82	●	-
251 ETZ	81	●	-
251 SAXON TOUR	96	●	-
251 SPORTSTAR MUZ	96	●	-
300 ETZ LUX	90	●	-
300 ETZ X	88	●	-
301 ETZ	90	●	-
301 SAXON TOUR		●	-
301 SPORTSTAR MUZ	96	●	-
500 SAXON COUNTRY	92	●	-
500 SAXON FUN	92	●	-
500 SAXON VOYAGER		●	-
500 SILVER STAR CLASSIC	93	●	-

## NORTON

COMMANDER	90	●	●
INTERPOL	83	●	●
WANKEL CLASSIC	88	●	●
F 1	90	-	●

## OSSA

500 YANQEE	78	●	-
------------	----	---	---

## SWM

350 SAHARA		●	-
------------	--	---	---

## TRIUMPH

750 BONNEVILLE	87	●	●
----------------	----	---	---

## ZÜNDAPP

175 KS	81	●	-
--------	----	---	---





**07BB1507** 69.5 x 50.9 x 8.0

**07BB1510** 69.5 x 50.9 x 8.0

☉ Genuine Parts

**07BB1511** 55.6 x 53.6 x 8.0

☉ Genuine Parts

**07BB15RC** 55.6 x 53.6 x 8.0

**07BB15SA** 55.6 x 53.6 x 8.0

Sintered

**07BB15SC** 55.6 x 53.6 x 8.0

Sintered

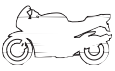
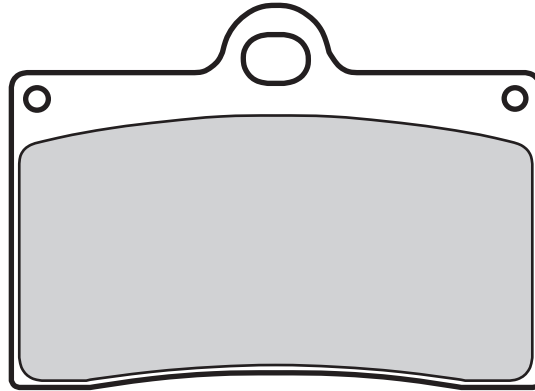

## APRILIA

250 AF1 REPLICA	90	●	-
250 RS	94	●	-
250 RS	95->97	●	-

## BETA

125 JONATHAN	99	●	-
350 4.0 MOTARD	04	●	-
350 EURO	99	●	-
350 JONATHAN	02	●	-
350 M4	06->	●	-

## BIMOTA

400 YB 7	94	●	-
500 V due	97	●	-
600 BELLARIA	90->92	●	-
600 BELLARIA	93	●	-
600 YB 9 SR, SRI	97	●	-
650 SUPERMONO BIPOSTO	97	●	-
750 SB7	94	●	-
750 YB 4	88	●	-
851 TESI	91	●	-
900 DB2	93	●	-
900 DB2 SR	94	●	-
900 MANTRA	97	●	-
906 TESI	91	●	-
1000 DB 1 RS	87	●	-
1000 DB 1	91	●	-
1000 FURANO	92	●	-
1000 TESI 2D	04->06	●	-
1000 TUATARA	90	●	-
1000 YB 6	87	●	-
1000 YB 8	89	●	-
1000 YB 11	97	●	-
1100 SB6	94	●	-
1100 SB6	97	●	-

## CAGIVA

125 MITO 2	92->93	●	-
------------	--------	---	---



125 MITO EV	94->03	●	-
125 MITO EURO2	04->	●	-
125 MITO 525	08->	●	-
125 N1	96	●	-
125 PLANET	98->00	●	-
125 RAPTOR	03	●	-
600 RIVER	94	●	-

## DUCATI

350 SUPERSPORT 350	92	●	-
400 MONSTER 400	95->97	●	-
400 SUPERSPORT 400	93->97	●	-
500 502 SINGLE	93	●	-
500 502 SUPERMONO	93	●	-
600 MONSTER 600	93->97	●	-
600 MONSTER 600, DARK	98	●	-
600 MONSTER 600 CITY, DARK CITY	99	●	-
600 SUPERSPORT 600	91->97	●	-
748 748 BIPOSTO	95->97	●	-
748 748 BIPOSTO	98	●	-
748 748 SP	95->97	●	-
750 F1	86	●	-
750 LAGUNA SECA	87	●	-
750 MONSTER 750 (bidisco)	96->98	●	-
750 MONSTER 750 (monodisco)	96->97	●	-
750 MONSTER 750 CITY, DARK CITY	99	●	-
750 SUPERSPORT 750	91->98	●	-
851 851	89	●	-
851 851 SP2	90	●	-
851 851 SP3 / 851 SUPERBIKE	91	●	-
888 888 RACING	92	●	-
888 888 SP4	92	●	-
888 888 SP5	93	●	-
888 888 SUPERBIKE STRADA	94->95	●	-
888 SPORT PRODUCTION	92	●	-
900 FE	97	●	-
900 MONSTER 900	93->99	●	-



900 MONSTER 900 CITY, DARK CITY	99	●	-
900 MONSTER 900 CROMO	98	●	-
900 MONSTER 900 SPECIAL	98	●	-
900 SUPERLIGHT 900	92->97	●	-
900 SUPERSPORT 900	90->97	●	-
907 I.e.	92	●	-
916 916	94->96	●	-
916 916 BIPOSTO, SENNA	94->98	●	-
916 916 S, 916 SP	94->96	●	-
916 916 SPS	97	●	-

## GAS GAS

125 SM	02	●	-
250 SM	02	●	-
400 FSE SM	02	●	-
450 FSE SM	03->06	●	-
450 SM FSR	07->	●	-

## GILERA

350 SATURNO	88	●	-
500 SATURNO	88	●	-
600 SATURNO PIUMA	90	●	-

## HONDA

125 RS (GP)	95	●	-
250 RS R	93	●	-

## HUSQVARNA

400 SM R	02	●	-
450 SMR	03->	●	-
570 SMR	01	●	-
570 SMR	02	●	-
570 SMR R	04	●	-

## ITALJET

900 GRIFON	00	●	-
------------	----	---	---

## KTM

125 STING	99	●	-
-----------	----	---	---





400	DUKE	94->95	●	-
450	SM FACTORY REPLICA	04	●	-
450	SMR	04	●	-
525	SMR	04	●	-
620	DUKE	94->97	●	-
640	DUKE	98	●	-
640	LC4 SUPERMOTO	03->04	●	-
660	SM FACTORY	02	●	-
660	SM FACTORY REPLICA	03	●	-
660	SMC	03	●	-
660	SMS	07->	●	-

## LAVERDA

650	FORMULA	94->95	●	-
650	GHOST	96	●	-
650	SPORT	94->95	●	-
650	STRADA	96	●	-
668	668	96	●	-
668	DIAMANTE	96->98	●	-
668	GHOST / STRIKE / LEGEND	96->98	●	-
750	CUP	98	●	-
750	DIAMANTE	97	●	-
750	GHOST STRIKE	97	●	-
750	S FORMULA	99->00	●	-
750	S, S SCARENATO	97->98	●	-
750	750 S SPORT	99->00	●	-
750	STRIKE BIFARO	98->99	●	-
750	STRIKE MONOFARO	98->99	●	-
750	T8	98	●	-



800	TTS	99	●	-
-----	-----	----	---	---

## MOTO GUZZI

1000	DAYTONA	92->95	●	-
1000	DAYTONA RACING	92->96	●	-
1000	DAYTONA RS	97->98	●	-
1000	V10 CENTAURO	97->99	●	-
1100	CALIFORNIA EV	97->00	●	-
1100	CALIFORNIA JACKAL BASIC	00	●	-
1100	CALIFORNIA SPECIAL	99->00	●	-
1100	SPORT	94->96	●	-
1100	SPORT CORSA	98->99	●	-
1100	SPORT INIEZIONE	96->99	●	-

## MZ

660	SKORPION CUP MUZ	99	●	-
660	SKORPION REPLICA MUZ	97	●	-

## NORTON

F 1	90	●	-
TT	92	●	-

## PGO

250	G-MAX	06	●	-
-----	-------	----	---	---

## SACHS

125	X-ROAD 4T	05	●	-
125	XTC	99	●	-



125	XTC N	99	●	-
650	ROADSTAR	01	●	-
800	B 805	02	●	-
800	ROADSTAR	00	●	-
800	S 805	03	●	-

## TM

125	SMR	05	●	-
125	SMX	06	●	-
400	SMR F	02	●	-
400	SMR F	03	●	-
450	SMR F	04	●	-
530	SMR F	03	●	-
600	SMX F	03	●	-

## VOR

400	SM	02	●	-
450	SM	02	●	-
500	SUPERMOTARD (492)	00->01	●	-
530	SM	02	●	-

## VOXAN

1000	CAFE RACER	01	●	-
1000	ROADSTAR	01	●	-

## YAMAHA

125	TZR R ITALIA	92	●	-
250	TZR R	94	●	-
660	SZR	96	●	-

3



**07BB1606** 100.1 x 51.7 x 7.6

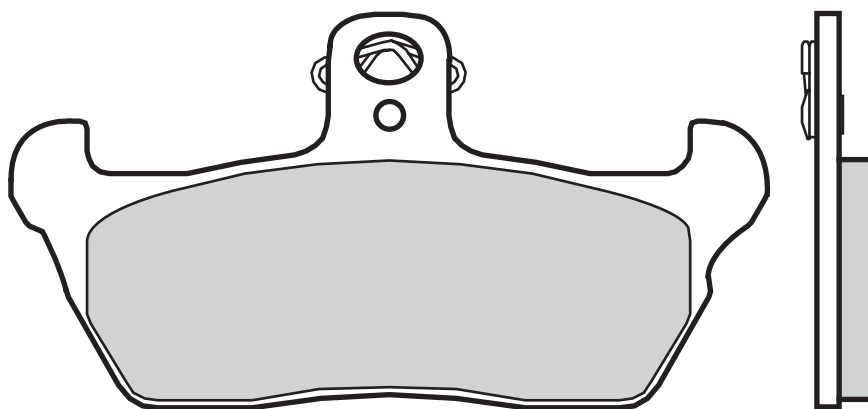

## APRILIA

125	RX	91	●	-
125	TUAREG RALLY	90->91	●	-
350	TUAREG	88	●	-
350	TUAREG WIND	90	●	-
600	TUAREG	88	●	-



## CAGIVA

80	SUPER CITY	94	●	-
125	FRECCIA C10	88->89	●	-
125	FRECCIA C12	89	●	-
125	FRECCIA C10 ANNIVERSARY	89	●	-
125	K 7	90	●	-



125	MITO	90	●	-
125	N 90	90	●	-
125	SUPER CITY	92	●	-
125	TAMANACO	89	●	-
125	W9	96	●	-
350	W12	92	●	-
500	W16	94->98	●	-



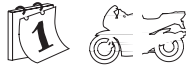
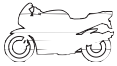

600	W16	94	●	-
750	ELEFANT	88->90	-	●

## GILERA

125	APACHE	91->93	●	-
600	R, RC	91	●	-

## MOTO GUZZI

1000	QUOTA	92->95	-	●
------	-------	--------	---	---

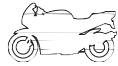

## MOTO MORINI

350	COGUARO, NEW YORK	89	●	-
350	DART	87	●	-
350	DART	88->89	●	-
350	EXCALIBUR	87	●	-
350	KANGURO	87	●	-
400	DART	90	●	-
501	COGUARO	89	●	-

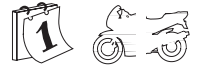
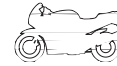

501	EXCALIBUR	90	●	-
501	KANGURO	87	●	-
501	NEW YORK	89	●	-

## SUZUKI

250	WOLF	90	●	-
-----	------	----	---	---

## YAMAHA

125	TDR R ITALIA	92	●	-
-----	--------------	----	---	---



**07BB1710** 39.7 x 49.5 x 6.3  
 Genuine Part

**07BB1750** 39.7 x 49.5 x 6.3  
 Genuine Part  
 Sintered

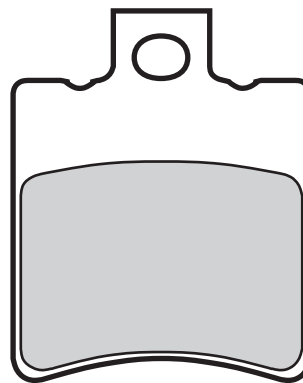

3



## APRILIA

50	AMICO F-X-SPORT	92->94	●	-
50	BUSINESS	97	●	-
50	CLASSIC	96	●	-
50	CLUB	97	●	-
50	MC GULLIVER	95	●	-
50	RALLY AC	96	●	-
50	RALLY LC	92->96	●	-
50	RALLY LC	97	●	●
50	SCARABEO	94->97	●	-
50	SCARABEO	98->01	●	-
50	SCARABEO DE LUXE	98	●	●
50	SCARABEO STREET	98	●	-
50	SCARABEO DITECH	02	●	-
50	SONIC GP/SPICE	98	●	-
50	SR R	05->	●	-
50	SR R FACTORY	05->	●	-
50	SR RACING	97	●	-
50	SR STREET	05->	●	-
50	STEALTH LC	97	●	-
50	SR DITECH	00	●	-
50	YOUNGER	97	●	-

## ATALA

50	BYTE AT 10	95	●	-
50	HACKER AT 12	96	●	-



50	SKEGGIA	99	●	-
----	---------	----	---	---

## BENELLI

50	491 GT, SPORT	97	●	●
50	491 NAKED	99	●	-
50	491 ST	01	●	-
50	ARMY, RACING, SUPERBIKE	97	●	●
50	CHRONO	94	●	-
50	K2	98	●	●
50	NAMUR	99	●	●
50	PEPE	99->04	●	-
100	NAKED	02	●	-
100	PEPE	99	●	-
150	VELVET	00->04	●	●
150	VELVET TOURING	01	-	●
400	VELVET DUSK	03	-	●

## BETA

50	ARK	96->98	●	-
50	ARK	99	●	●
50	EIKON	99->03	●	●
50	EIKON	04	●	-
50	QUADRA	95->96	●	-
50	TEMPO	99	●	-
50	TEMPO "13"	00	●	-
50	TEMPO "16"	00	●	-
125	EIKON	00->03	●	-



150	EIKON	00	●	-
-----	-------	----	---	---

## BIMOTA

1000	SB8 K GOBERT	04->	-	●
1000	SB8 K SANTAMONICA	04->06	-	●
1000	TESI 2D	04->06	-	●

## BS VILLA

50	AX	93	●	-
50	GZ	93	●	-

## CAGIVA

125	CUCCILO	98->99	●	-
-----	---------	--------	---	---

## DERBI

50	VAMOS (Brembo cal.)	95->97	●	-
----	---------------------	--------	---	---

## GARELLI

50	FLO'	00	●	-
125	PANTHER	02	-	●
150	PANTHER	02	-	●
250	PANTHER	02	-	●

## GILERA

50	DNA	01	-	●
50	EAGLET	97	●	-
50	EASY MOVING	96	●	-





50	ICE	02	●	-
50	NRG	94	●	-
50	RUNNER	96->05	●	-
50	STALKER	97->	●	-
50	STORM	96	●	-
50	TYPHOON	93->95	●	-
70	RUNNER	98	●	-
80	TYPHOON	95	●	-
125	DNA	01	-	●
125	TYPHOON XR	95	●	-
180	DNA	01	-	●
250	STALKER	97	●	-

## HERCULES

50	GIPSY	95	●	-
----	-------	----	---	---

## HONDA

50	FORMULA	94	●	-
50	SFX	96	●	-
50	SH FIFTY	95	●	-
50	SH	00	●	-
50	SKY	96	●	-
50	SKY CLASSIC, VETRO	00	●	-
50	SXR	98	●	-

## HYOSUNG

125	EXCEED	02	●	-
125	GPS D	00	●	-
125	GRAN PRIX PLUS	98->01	●	-
125	HYPER	99	●	-
150	EXCEED	02	●	-
150	GRAN PRIX PLUS	98	●	-

## ITALJET

50	FORMULA	94	-	●
80	FORMULA	94	-	●
125	FORMULA	94	-	●

## MALAGUTI

50	CENTRO SL	93	●	-
50	CIAK	02	●	●
50	CIAK ELETTRIC POWER	03	●	-
50	CIAK MASTER	06->	●	-
50	CROSSER	97	●	-
50	FIREFOX	05	●	●
50	F10	94	●	-
50	F10 TIMEMACHINE	03	●	-
50	F10 WAP	02->	●	-
50	F12 PHANTOM	98->99	-	●
50	F12 PHANTOM DIGIT	00	-	●



50	F12 PHANTOM DUCATI CAPIREX	04->	●	●
50	F12 PHANTOM GP	04->	●	●
50	F12 PHANTOM SPECTRUM	00	●	●
50	F12 PHANTOM FOGGY	00	●	●
50	F12 RACING LIFE	03	●	●
50	F12 TYRE TRACK	03	●	●
50	F15 FIREFOX BLUE RACE	05->	●	●
50	F15 FIREFOX DUCATI SBK	04->	●	●
50	F15 FIREFOX FUN	03	●	●
50	F15 FIREFOX MECHATRONIC	03	●	●
50	F15 FIREFOX RED RACE	05->	●	●
50	F15 FIREFOX TDS	99	●	●
50	YESTERDAY	97	●	-
100	CIAK	99	●	●
100	F 12 PHANTOM A.C.	00->01	●	-
100	F 12 PHANTOM TWIN DISK	02	●	●
125	F18 PROJECT	00	●	-
125	F18 WARRIOR	00	●	-
150	F18 PROJECT	00	●	-
150	F18 WARRIOR	00	●	-

## MBK

50	BOOSTER R	93->95	●	-
50	BOOSTER N.G.	96	●	-
50	BOOSTER NAKED	04	●	-
50	BOOSTER all model	96->99	●	-
50	BOOSTER SPIRIT	00	●	-
50	FIZZ	94	●	-
50	FLIPPER	98	●	-
50	FORTE	94	●	-
50	MACH	02	●	-
50	NEO'S	94	●	-
50	NITRO	97	●	-
50	OVETTO	96	●	-
100	NITRO	00	●	-
100	OVETTO	00	●	-

## MOTRON

50	SPIKE-S	98	●	-
50	STING	96	●	-
50	SYNCRO	99	●	-
50	ZR THUNDER	95	●	-

## PEUGEOT

50	BUXY R (Brembo cal.)	94->97	●	-
----	----------------------	--------	---	---



50	SPEEDAKE (Brembo caliper)	94->97	●	-
50	SPEEDFIGHT (Brembo cal.)	96	●	-
50	SQUAB	94	●	-
50	ZENITH LUXE	94	●	-

## PIAGGIO

50	ENERGY EXTREME DT	99	●	-
50	ENERGY EXTREME DD	99	●	-
50	FREE	97	●	-
50	NRG DD	02	●	-
50	NRG DT	02	●	-
50	NTT	96	●	-

## SIAMOTO

50	FALCON	97	●	-
50	S CROSS	97	●	-
125	FALCON	97	●	-

## SUZUKI

50	KATANA LC	97	●	-
50	KATANA RX	98	●	-
50	R7	95->97	●	-
50	RF	95->97	●	-
50	W, WR	00	●	-

## VILLA

50	GZ		●	-
----	----	--	---	---

## YAMAHA

50	AEROX	97	●	-
50	AXIS	95->96	●	-
50	AXIS MOFA	97	●	-
50	BREEZE	94	●	-
50	BW'S BUMP	95	●	-
50	BW'S NEXT GENERATION	99	●	-
50	BW SPORT R	02	●	-
50	OG R/RR	02	●	-
50	JOG-Z	93->00	●	-
50	NEO'S	96	●	-
50	OVETTO	96	●	-
50	SPY	96	●	-
50	YE ZEST	92	●	-
50	YH	98	●	-
50	WHY	98	●	-
80	YE ZEST	93	●	-
100	AEROX	00	●	●
100	NEO'S	00	●	-





**07BB1810** 39.7 x 49.5 x 7.0

☉ Genuine Parts

**07BB1811** 39.7 x 49.5 x 7.0

☉ Genuine Parts

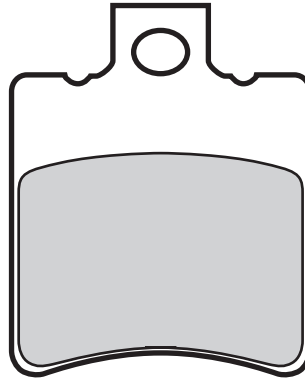

### ANCILLOTTI

80	CROSS	80	●	-
----	-------	----	---	---

### APRILIA

50	AREA 51	98	●	●
50	GULLIVER	96->98	●	-
50	HABANA	99	●	-
50	HABANA CUSTOM	99	●	-
50	SR EUROPA	93	●	-
50	SR URBAN KID	93	●	-
50	VIPER-REPLICA	94	●	-
50	SCARABEO	98->01	-	●
125	RX	85	●	-
125	LEONARDO	95->98	-	●
150	LEONARDO	96->98	●	●
250	RX	86	●	-
250	RS	94	-	●
250	RS	95->97	-	●
250	RS	98->01	-	●

### BENELLI

100	K2	99	●	-
125	ADIVA	00	●	-
125	VELVET	99->04	●	●
125	VELVET TOURING	01	●	●
150	ADIVA	00	●	-
150	VELVET TOURING	01	●	-
250	VELVET	99	-	●
250	VELVET TOURING	01	-	●



### FANTIC MOTOR

50	CABALLERO RS / RC	90	●	-
----	-------------------	----	---	---

### GARELLI

125	TIGER XR, XRD	83	●	-
-----	---------------	----	---	---

### HONDA

50	X8R S, X	98	●	-
100	SH FIFTY	96	●	-

### MACAL

50	FLASH	99	●	-
----	-------	----	---	---

### MALAGUTI

125	CIAK	00->	●	-
125	CIAK MASTER	00->	●	-
150	CIAK	00->	●	-
150	CIAK MASTER	00->	●	-

### MBK

50	EQUALIS	96	●	-
50	EVOLIS	92	●	-
80	EVOLIS	94	●	-
125	DOODO	00	●	-
150	DOODO	01	●	-

### PEUGEOT

125	ENDURO	84	●	-
-----	--------	----	---	---

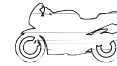

### PGO

50	RODO SHOW	01	●	-
90	RODO SHOW	02	●	-

### PIAGGIO

50	NRG all model	95->97	●	-
50	NRG EXTREME	01	●	-
50	NRG DD	02	-	●
50	NRG POWER DD	05	●	●
50	NRG PUREJET	05	●	●
50	STORM	94->95	●	-
50	TYPHOON	94->95	●	-
50	TYPHOON CATALYZED	02	●	●
50	VESPA LXV	08->	●	-
50	ZIP FAST RIDER	93->95	●	-
100	FREE	02	●	-
125	HEXAGON	94->97	●	-
125	TYPHOON CATALIZ.	02	●	●
125	VESPA LXV	08->	●	-
150	HEXAGON	94->97	●	-
150	VESPA LX	08->	●	-

### SUZUKI

50	AP	95->97	●	-
----	----	--------	---	---

### YAMAHA

125	TEO'S	99	●	-
150	TEO'S	02	●	-







**07BB1907** 74,9 x 55.5 x 8.6

**07BB1910** 74,9 x 55.5 x 8.6

☉ Genuine Parts

**07BB1950** 74,9 x 55.5 x 8.6

☉ Genuine Parts  
Sintered

**07BB1951** 74,9 x 55.5 x 8.6

☉ Genuine Parts  
Sintered

**07BB1952** 74,9 x 55.5 x 8.6

☉ Genuine Parts  
Sintered

**07BB19RC** 74,9 x 55.5 x 8.6

**07BB19SA** 74,9 x 55.5 x 8.6

Sintered

**07BB19SC** 74,9 x 55.5 x 8.6

Sintered

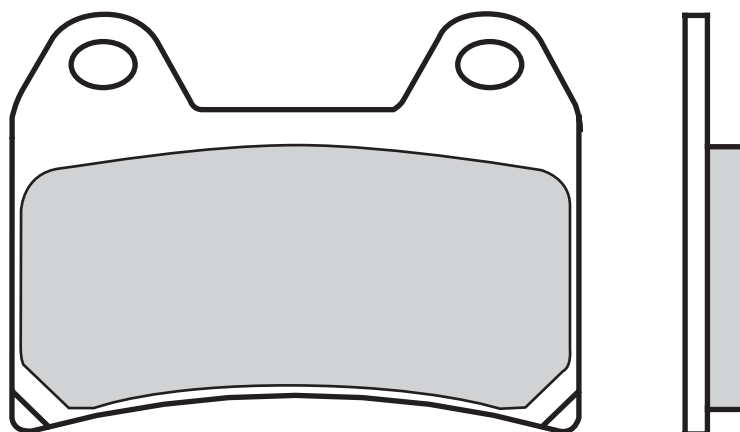

3



## APRILIA

250 RS	98->01	●	-
650 PEGASO STRADA	05->	●	-
750 SMV DORSODURO	08->	●	-
1000 BLU MARTIN	02	●	-
1000 RST FUTURA	01->04	●	-
1000 RSV	98->99	●	-
1000 RSV R	00	●	-
1000 RSV SL FALCO	00->04	●	-
1000 RSV SP	99	●	-
1000 TUONO FIGHTER	03	●	-

## BENELLI

125 BORN IN HELL	98	●	-
900 TORNADO 3	00->02	●	-
1100 TNT	04	●	-
1130 TNT	05	●	-
1130 TRE-K	06->	●	-

## BIMOTA

900 DB4	99	●	-
1000 SB8 K GOBERT	04->	●	-
1000 SB8 K SANTAMONICA	04->06	●	-
1000 SB8 R	98	●	-

## BMW

650 G 650 Xmoto	07->	●	-
800 F 800 S	06->	●	-
800 F 800 ST	06->	●	-



## CAGIVA

125 RAPTOR	05	●	-
650 RAPTOR	01->05	●	-
650 V-RAPTOR	01->05	●	-
1000 RAPTOR	00	●	-
1000 V-RAPTOR	00	●	-
1000 XTRA RAPTOR	02	●	-
1000 X3 RAPTOR	04	●	-

## DUCATI

400 MONSTER 400	03->04	●	-
400 MONSTER 400 (Monodisco)	05	●	-
400 MONSTER 400 DARK	03	●	-
600 MONSTER 600, DARK, DARK CITY	00	●	-
600 MONSTER 600 METALLIC	00->01	●	-
620 MONSTER 620 (Bidisco)	05	●	-
620 MONSTER 620, DARK	04	●	-
620 MONSTER 620 DARK (Monodisco)	04	●	-
620 MONSTER 620 DARK (Monodisco)	05	●	-
620 MONSTER 620 i.e., MONSTER 620 S i.e.	02	●	-
620 MONSTER 620 i.e., MONSTER 620 S i.e., DARK	03	●	-
620 MONSTER 620 i.e. DARK	02	●	-

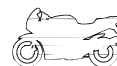

620 MULTISTRADA 620 DARK (Monodisco)	05	●	-
620 MULTISTRADA 620 DS	03	●	-
620 SUPERSPORT 620 S	03	●	-
696 MONSTER 696	08->	●	-
748 748	00->02	●	-
748 748 BIPOSTO	99	●	-
748 748 R	00	●	-
748 748 S	00->02	●	-
748 748 SPS	98->99	●	-
750 MONSTER 750, METALLIC, DARK	00->01	●	-
750 MONSTER 750 DARK i.e.	02	●	-
750 SPORT	00	●	-
750 SUPERSPORT 750	99	●	-
750 SUPERSPORT 750 i.e.	00->02	●	-
750 SUPERSPORT 750 S i.e.	02	●	-
803 MONSTER 800	04	●	-
803 MONSTER 800 S i.e.	03	●	-
803 SUPERSPORT 800	06	●	-
803 SUPERSPORT 800 S	03	●	-
803 SUPERSPORT 800 SS	03	●	-
848 848,00	08->	●	-
900 MH 900 EVOLUZIONE	01->02	●	-
900 MONSTER 900, DARK i.e.	02	●	-
900 MONSTER 900 i.e., 900 S i.e., DARK i.e., METALLIC i.e., CROMO i.e.	00	●	-
900 MONSTER 900 S i.e., DARK i.e., METALLIC i.e., CROMO i.e.	01	●	-
900 SUPERSPORT 900	98->99	●	-



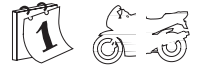
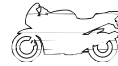
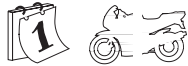
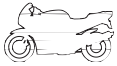

900	SUPERSPORT 900 i.e.	00->02	●	-
900	SUPERSPORT 900 S i.e.	02	●	-
900	SPORT TOURING 4	99	●	-
916	916 SPS	98	●	-
916	MONSTER S4, S4 FOGGY	02->03	●	-
916	SPORT TOURING 4	00->03	●	-
916	SPORT TOURING 4	99	●	-
916	SPORT TOURING 4 S	03->04	●	-
916	SPORT TOURING 4 S (ABS)	03->04	●	-
944	SPORT TOURING 2	99->00	●	-
992	MONSTER 1000	04->05	●	-
992	MONSTER 1000 S	05	●	-
992	MONSTER 1000 S i.e.	03	●	-
992	MONSTER S2 R 1000	06->	●	-
992	MULTISTRADA 1000 DS	03->	●	-
992	MULTISTRADA 1000 S DS	05->	●	-
992	ST3	04->	●	-
992	ST3 ABS, ST3 S ABS	07->	●	-
992	ST4, ST4 ABS	05	●	-
992	SUPERSPORT 1000	06->	●	-
992	SUPERSPORT 1000 DS	05	●	-
992	SUPERSPORT 1000 S	03	●	-
996	996, 996 S	01	●	-
996	996, 996 S, 996 SPS, 996 SPS III	00	●	-
996	996, 996 SPS, 996 SPS II	99	●	-
996	MONSTER S4 R	03	●	-
996	MONSTER S4 R	04->	●	-
998	998	02	●	-
998	998 Matrix	04	●	-
1100	HYPERMOTARD	07->	●	-
1078	MULTISTRADA 1100	07->	●	-
1078	MULTISTRADA 1100 S	07->	●	-

## HUSQVARNA

570	NOX	01->03	●	-
610	LT	00	●	-
610	SM	98->99	●	-
610	SMS	00->01	●	-
610	SMS	03->04	●	-
610	TE E LT	00	●	-

630	SMR	04	●	-
-----	-----	----	---	---

## KTM

625	SMC	05->	●	-
640	DUKE II	99->04	●	-
640	DUKE II	05->07	●	-
640	LC4 SUPERMOTO	05->	●	-
660	SMC	04	●	-
660	SMC	06->	●	-
690	SUPERMOTO	07->	●	-

## MOTO GUZZI

750	BREVA 750 i.e.	03->06	●	-
750	NEVADA	03	●	-
750	NEVADA CLASSIC i.e.	06->	●	-
850	BREVA 850	06->	●	-
850	GRISO 850	06->	●	-
1100	BREVA	05->	●	-
1100	BREVA ABS	05->	●	-
1100	CALIFORNIA CLASSIC, TOURING	06->	●	-
1100	CALIFORNIA EV	01->05	●	-
1100	CALIFORNIA EV	06->	●	-
1100	CALIFORNIA EV TOURING	04->	●	-
1100	CALIFORNIA EV, EV TOURING	03	●	-
1100	CALIFORNIA EV, SPORT	01->02	●	-
1100	CALIFORNIA JACKAL	99->01	●	-
1100	CALIFORNIA JACKAL BASIC	01	●	-
1100	CALIFORNIA SPECIAL	01	●	-
1100	CALIFORNIA SPECIAL SPORT	02	●	-
1100	CALIFORNIA SPECIAL SPORT, SPECIAL ALLUMINIUM	02->	●	-
1100	CALIFORNIA STONE	01->05	●	-
1100	CALIFORNIA STONE, METAL	02->	●	-
1100	CALIFORNIA ALLUMINIUM, TITANIUM	03	●	-
1100	CALIFORNIA VINTAGE	07->	●	-
1100	GRISO	05->	●	-
1100	SPORT	01	●	-
1100	V11 COPPA ITALIA	04	●	-
1100	V11 SCURA	02	●	-

1100	V11 LE MANS	01	●	-
1100	V11 CAFE SPORT / BALLABIO	03	●	-
1100	V11 LE MANS / NAKED / SPORT	01->02	●	-
1100	V11 LE MANS / NAKED	03	●	-
1100	V11 SPORT ROSSO	01	●	-
1200	GRISO 8V	07->	●	-
1200	NORGE, ABS	06->	●	-
1200	SPORT	06->	●	-
1200	SPORT ABS	06->	●	-
1200	STELVIO	08->	●	-

## MOTO MORINI

950	9 1/2	06->	●	-
1200	CORSARO	06->	●	-

## MV AGUSTA

989	BRUTALE R	08->	●	-
-----	-----------	------	---	---

## MZ

1000	MUZ S	01->02	●	-
------	-------	--------	---	---

## SACHS

500	MADASS	05	●	-
-----	--------	----	---	---

## SUZUKI

1200	GSX	99->01	●	-
------	-----	--------	---	---

## TM

530	SMR F ES	03	●	-
-----	----------	----	---	---

## VOXAN

1000	EVO	04	●	-
------	-----	----	---	---

## YAMAHA

400	XJR R	95	●	-
660	XT X	04->	●	-
850	TRX	95	●	-
1200	XJR ITALIA	95->98	●	-





**07BB2010** 50.2 x 53.2 x 7.8

☉ Genuine Parts

**07BB2011** 50.2 x 53.2 x 7.8

☉ Genuine Parts

**07BB2050** 50.2 x 53.2 x 7.8

☉ Genuine Parts  
Sintered

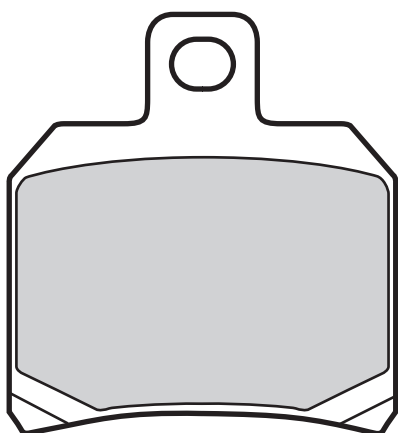

## ADIVA

250 ADIVA	06->	•	•
-----------	------	---	---

## APRILIA

50 RS	06->	•	-
1000 ETV CAPO NORD	01->03	-	•
1000 ETV CAPO NORD ABS	04	-	•
1000 ETV CAPO NORD RALLY RAID	04	-	•
1000 BLU MARTIN	02	-	•
1000 RSV	98->99	-	•
1000 RSV FACTORY	04->	-	•
1000 RSV NERA	04	-	•
1000 RSV R	00	-	•
1000 RSV R	01->03	-	•
1000 RSV SL FALCO	00->04	-	•
1000 RSV SP	99	-	•
1000 TUONO R	03->	-	•
1000 TUONO FIGHTER	03	-	•
1000 TUONO RACING	04	-	•

## BENELLI

756 CUE	07->	-	•
900 TORNADO 3	03	-	•
1130 TNT	05	-	•
1130 TNT SPORT	05->	-	•
1130 TNT CAFE' RACER	05->	-	•
1130 TNT TITATIUM	05->	-	•
1130 TORNADO TRE	06->	-	•
1130 TRE-K	06->	-	•

## BIMOTA

1000 DB5	05->	-	•
1000 DB6 DELIRIO	06->	-	•
1098 DB7	08->	-	•

## CAGIVA

650 RAPTOR	01->05	-	•
650 V-RAPTOR	01->05	-	•
1000 RAPTOR	00	-	•
1000 V-RAPTOR	00	-	•
1000 X-RAPTOR	03	-	•
1000 XTRA RAPTOR	02	-	•

1000 X3 RAPTOR	04	-	•
----------------	----	---	---

## DERBI

50 GPR NUDE	04->	•	-
50 GPR RACING	04->	•	-
50 GP1	05->	•	-
125 GP1	05->	•	-
250 GP1	05->	•	-
659 MULHACÉN	06->	-	•
659 MULHACÉN CAFE'	08->	-	•

## DUCATI

620 MULTISTRADA 620 DS	03	-	•
620 SUPERSPORT 620 S	03	-	•
696 MONSTER 696	08->	-	•
748 749	03->07	-	•
748 749 DARK	05->06	-	•
748 749 R	03->07	-	•
748 749 S	03->07	-	•
750 SPORT	00	-	•
750 SUPERSPORT 750	99	-	•
750 SUPERSPORT 750 i.e.	00->02	-	•
750 SUPERSPORT 750 S i.e.	02	-	•
803 SUPERSPORT 800	06	-	•
803 SUPERSPORT 800 S	03	-	•
803 SUPERSPORT 800 SS	03	-	•
848 848	08->	-	•
900 MH 900 EVOLUZIONE	01->02	-	•
900 SUPERSPORT 900	98->99	-	•
900 SUPERSPORT 900 i.e.	00->02	-	•
900 SUPERSPORT 900 S i.e.	02	-	•
900 SPORT TOURING 4	99	-	•
916 SPORT TOURING 4	00->03	-	•
916 SPORT TOURING 4	99	-	•
916 SPORT TOURING 4 S	03->04	-	•
916 SPORT TOURING 4 S (ABS)	03->04	-	•
944 SPORT TOURING 2	99->00	-	•
990 Desmosedici RR (D16RR)	07->	-	•
992 MULTISTRADA 1000 DS	03->	-	•
992 MULTISTRADA 1000 S DS	05->	-	•
992 ST3	04->	-	•
992 ST3 ABS, ST3 S ABS	07->	-	•

992 ST4, ST4 ABS	05	-	•
992 SUPERSPORT 1000	06->	-	•
992 SUPERSPORT 1000 DS	05	-	•
992 SUPERSPORT 1000 S	03	-	•
998 999	03->07	-	•
998 999 R	03->07	-	•
998 999 S	03->07	-	•
998 999 XEROX	06	-	•
1099 1098	07->	-	•
1099 1098 S	07->	-	•
1099 1098 S Tricolore	07->	-	•
1100 HYPERMOTARD	07->	-	•
1100 HYPERMOTARD S	07->	-	•
1078 MULTISTRADA 1100	07->	-	•
1078 MULTISTRADA 1100 S	07->	-	•

## GILERA

500 NEXUS	03->05	-	•
500 NEXSUS (EURO 3)	06->	-	•
500 NEXSUS SP (EURO 3)	06->	-	•
800 GP 800	07->	-	•

## KTM

1190 RC8	08->	-	•
----------	------	---	---

## LAVERDA

800 TTS	99	-	•
1000 SFC 1000 (Limited Edition)	03	-	•

## MBK

125 SKYCRUISER	06->	-	•
125 SKYLINER	02	-	•
125 THUNDER	01	-	•
150 SKYLINER	01	-	•
150 THUNDER	02	-	•
180 SKYLINER	04	-	•

## MONDIAL

1000 PIEGA	02	-	•
1000 PIEGA EVO	04	-	•
1000 STARFIGHTER RZ	04	-	•
1000 PIEGA RZ NUDA	04	-	•



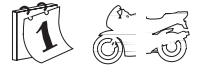
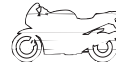
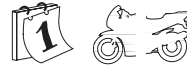
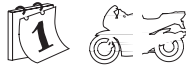
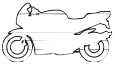

## MOTO GUZZI

750	BREVA 750 i.e.	03->06	-	•
750	NEVADA	03	-	•
750	NEVADA CLASSIC i.e.	06->	-	•
1200	MGS-01 CORSA	05->	-	•

## MOTO MORINI

950	9 1/2	06->	-	•
1200	CORSARO	06->	-	•

## PEUGEOT

500	SATELIS	06->	•	•
-----	---------	------	---	---

## PIAGGIO

125	X9	00->02	•	•
125	X9	03	•	-

180	X9	00->02	•	•
200	X9	03	•	•
250	X9	00->02	•	•
250	X9	03	•	-
500	BEVERLY	03->	•	-
500	X9	00->02	•	•
125	X8	04	-	•
125	X9 (right caliper)	04->05	-	•
200	X8	04	-	•
500	BEVERLY CRUISER	08->	•	•
500	X9 EVOLUTION, ABS	04->	-	•

## RIEJU

50	SMX PRO	08->	•	-
50	TANGO	08->	•	-
125	TANGO	08->	•	-
125	TANGO PRO	08->	•	-

## SUZUKI

125	BURGMAN	01->06	-	•
150	BURGMAN	04->	-	•

## VOXAN

1000	CAFE RACER	01	-	•
1000	EVO	04	-	•
1000	ROADSTAR	01	-	•

## YAMAHA

125	MAJESTY	01->	-	•
125	MAXSTER	01->	-	•
125	X-City	08->	-	•
150	MAJESTY	01->	-	•
150	MAXSTER	01->	-	•
180	MAJESTY	04->	-	•



## 07BB2107 57.6 x 56.6 x 8.9

- Per dischi con spessore maggiorato (ABS)
- For discs with bigger thickness (ABS)
- Pour discs avec épaisseur majorée (ABS)

## 07BB21SA 57.6 x 53.6 x 8.9

Sintered

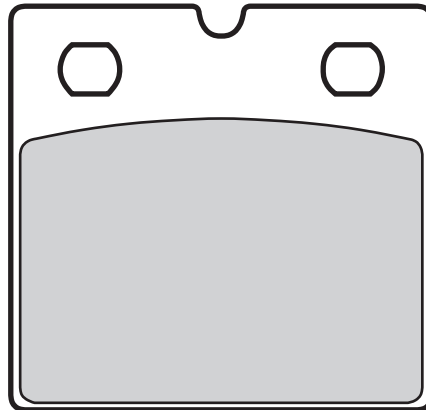

3

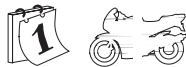

## BMW

750	K 75 RT	91	•	-
750	K 75 ABS (special caliper)	91	•	-
1000	K 100 ABS (special caliper)	91	•	-





**07BB2207** 99.6 x 55.6 x 8.3

**07BB22SA** 99.6 x 55.6 x 8.3

Sintered

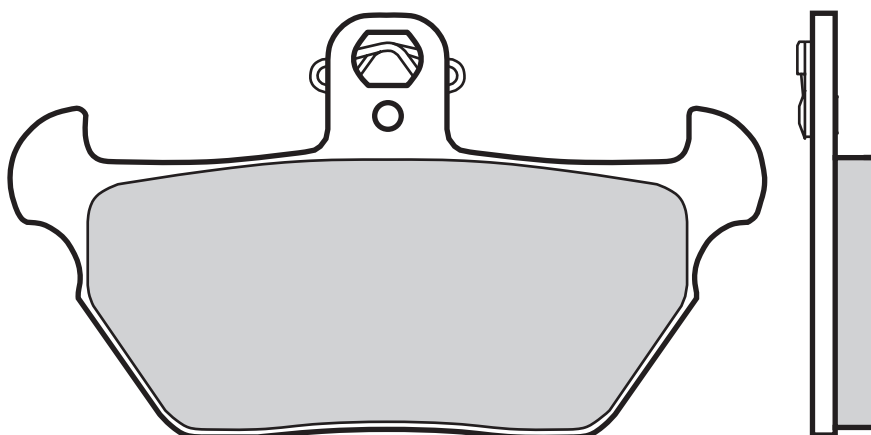

### BMW

800	R 80 R	92	●	-
1000	K 100 LT	92	●	-
1000	K 100 RS 16V	90	●	-
1000	K 1	89	●	-
1000	R 100 R	91	●	-
1000	R 100 R	92	●	-
1100	K 1100 LT	92	●	-
1100	K 1100 RS	93	●	-
1100	R 1100 RS	93	●	-

3



**07BB2307** 59.7 x 58.5 x 9.0

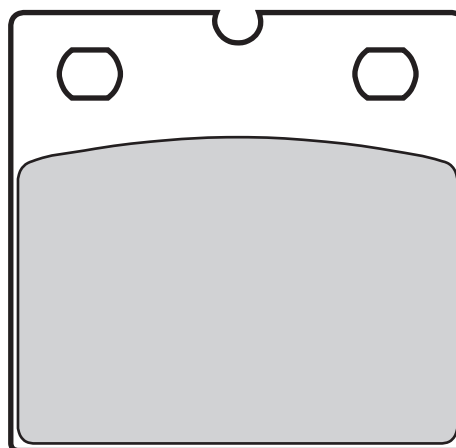

### BENELLI

900	SEI	78	-	●
-----	-----	----	---	---

### BMW

800	R 80 GS	88	●	-
1000	R 100 GS	88	●	-

### MOTO GUZZI

850	850 LE MANS	76->80	-	●
850	850 T3 GERMANIA	75	-	●
850	850 T3 CALIFORNIA	76	-	●
1000	CALIFORNIA II	83->86	-	●
1000	GS CONVERT GERMANIA	75	-	●
1000	SP 1000	78	-	●

### TRIUMPH

750	BONNEVILLE	84	●	-
-----	------------	----	---	---





**07BB2407** 100.0 x 56.1 x 8.4

**07BB245A** 100.0 x 56.1 x 8.4  
Sintered

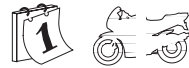
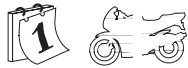
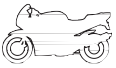
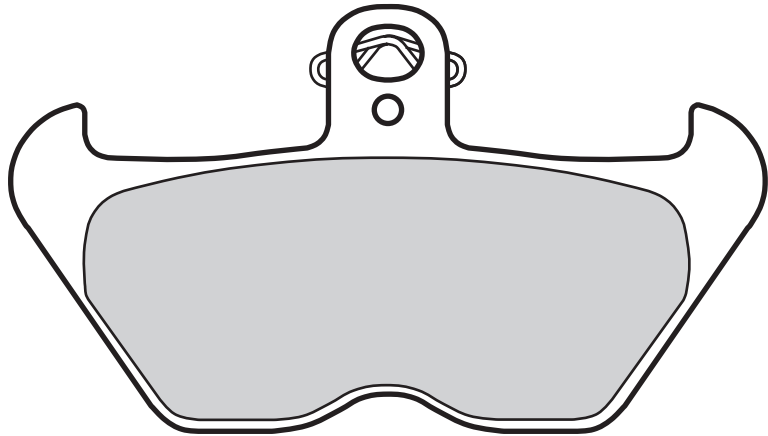

### BMW

850 R 850 C	99	●	-
850 R 850 GS	99	●	-
850 R 850 R	96->02	●	-
850 R 850 RT	98->00	●	-
1100 R 1100 R	99	●	-
1100 R 1100 S	99->00	●	-
1100 R 1100 GS, RS	94	●	-

1100 R 1100 R	95	●	-
1100 R 1100 RT	95	●	-
1150 R 1150 GS	00->01	●	-
1200 K 1200 LT	99->00	●	-
1200 K 1200 RS	97->00	●	-
1200 R 1200 C	98	●	-

3



**07BB2507** 74.9 x 54.6 x 8.9

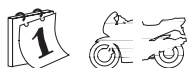
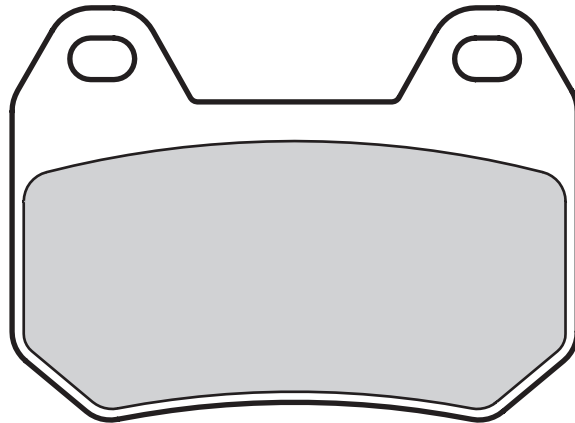

### BMW

1200 K 1200 LT	99->00	-	●
1200 K 1200 LT ABS	01->	-	●
1200 R 1200 CL	03	-	●





**07BB2607** 77.0 x 51.4 x 8.6

**07BB26SA** 77.0 x 51.4 x 8.6  
Sintered

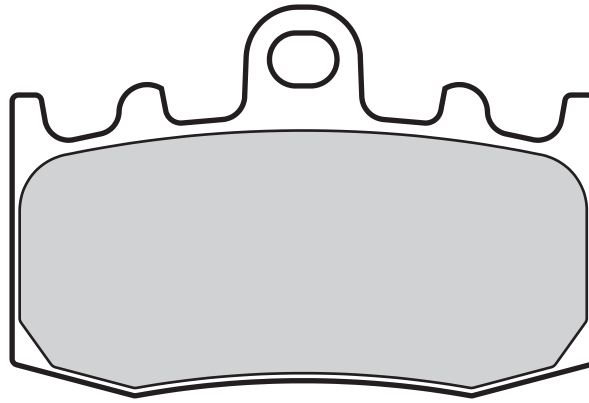

### BMW

125 C1	02->	●	-
200 C1	02->	●	-
850 R 850 RT ABS	01	●	-
1100 R 1100 S	01	●	-

1150 R 1150 GS, ADVENTURE	02	●	-
1150 R 1150 RT	01	●	-
1200 HP2 Megamoto	07->	●	-
1200 K 1200 GT ABS	02->	●	-
1200 K 1200 RS	01	●	-
1200 K 1200 S	05	●	-

1200 R 1200 GS	04->	●	-
1200 R 1200 GS ADVENTURE	06->	●	-
1200 R 1200 RT	05->	●	-
1200 R 1200 S	06->	●	-
1200 R 1200 ST	06->	●	-

3



**07BB2750** 64.0 x 41.8 x 8.0

☉ Genuine Parts  
Sintered

**07BB27SD** 64.0 x 41.8 x 8.0  
Sintered

**07BB27SX** 64.0 x 41.8 x 8.0  
Sintered

**07BB27TT** 64.0 x 41.8 x 8.0

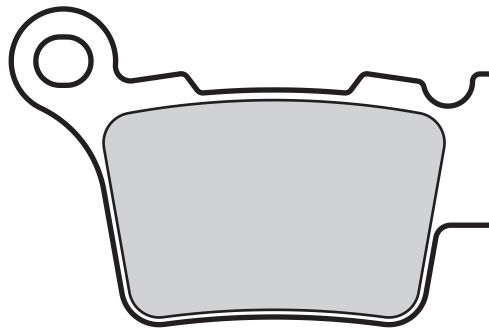

### HUSQVARNA

125 CR	05->	-	●
125 WR	05->	-	●
250 CR	05->	-	●
250 SMR	06->	-	●
450 SMR	06->	-	●
450 SMR R	06->	-	●
450 TC	04->	-	●
450 TE	06->	-	●
510 SM CENTENNIAL	06->	-	●
510 SMR	06->	-	●
510 TC	05->	-	●
510 TE	06->	-	●
510 TE Centennial	04	-	●

125 SX	04->	-	●
200 EXC	04->	-	●
200 SX	04	-	●
250 EXC	04->	-	●
250 EXC-F	06->	-	●
250 EXC RACING	05->	-	●
250 SX	03->	-	●
250 SX-F	06->	-	●
250 SXC	03	-	●
300 EXC	04->	-	●
300 SX	06->	-	●
400 EXC RACING	05->	-	●
450 EXC	04	-	●
450 EXC RACING	05->06	-	●
450 EXC RACING	07->	-	●
450 SM FACTORY REPLICA	04	-	●
450 SMR	04	-	●
450 SMR	05->06	-	●

450 SMR	07->	-	●
450 SX	04	-	●
450 SX RACING	05->	-	●
450 SX-F	07->	-	●
505 SX-F	07->	-	●
525 EXC	04	-	●
525 EXC RACING	05->	-	●
525 SMR	04	-	●
525 SMR	05	-	●
525 SX	04->	-	●
525 SX RACING	05	-	●
525 XC DESERT RACING	04->	-	●
530 EXC	08->	-	●
560 SMR	06->	-	●
660 SMC	04	-	●

### KTM

125 EXC	04->	-	●
---------	------	---	---

### RIEJU

450 MRX	08->	-	●
---------	------	---	---







**07BB28SP** 94.0 x 36.2 x 8.6  
94.0 x 36.2 x 10.1  
Sintered

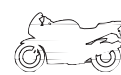
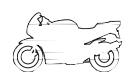
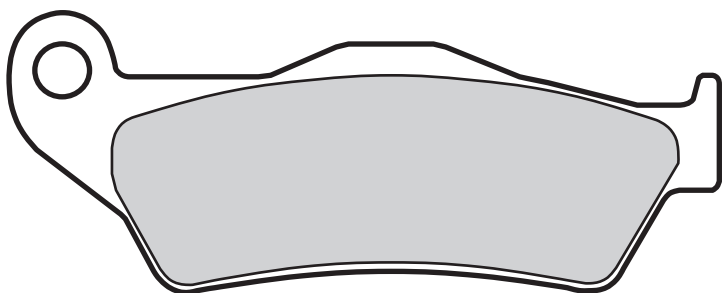
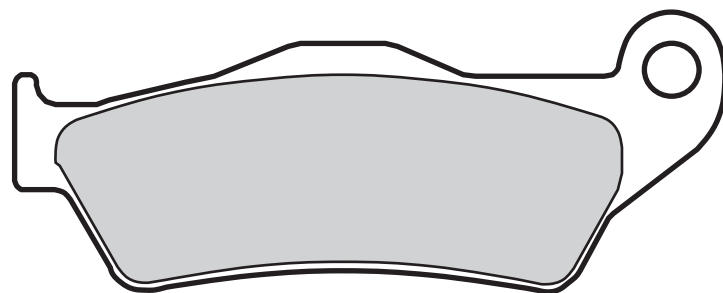

### BMW

850 R 850 C	99	-	●
850 R 850 GS	99	-	●
850 R 850 R	96->02	-	●
850 R 850 R	03	-	●
850 R 850 RT	98->00	-	●
850 R 850 RT ABS	01	-	●
1100 R 1100 R	99	-	●
1100 R 1100 S	99->00	-	●
1100 R 1100 S	01	-	●

1100 R 1100 S ABS	01	-	●
1100 R 1100 GS, RS	94	-	●
1100 R 1100 R	95	-	●
1100 R 1100 RT	95	-	●
1150 R 1150 GS	00->01	-	●
1150 R 1150 GS, ADVENTURE	02	-	●
1150 R 1150 R	01->	-	●
1150 R 1150 R ROCKSTER	02	-	●
1150 R 1150 RS	01	-	●
1150 R 1150 RT	01	-	●
1150 R 1150 S	03	-	●

1200 HP2 Megamoto	07->	-	●
1200 K 1200 R	05	-	●
1200 K 1200 R	07->	-	●
1200 K 1200 R Sport	07->	-	●
1200 K 1200 S	05	-	●
1200 R 1200 C	98	-	●
1200 R 1200 GS	04->	-	●
1200 R 1200 GS ADVENTURE	06->	-	●
1200 R 1200 R	07->	-	●
1200 R 1200 RT	05->	-	●
1200 R 1200 S	06->	-	●
1200 R 1200 ST	06->	-	●



**07BB3050** 102.2 x 42.0 x 7.4  
☉ Genuine Parts  
Sintered

**07BB3051** 102.2 x 42.0 x 7.4  
☉ Genuine Parts  
Sintered

**07BB30RC** 102.2 x 42.0 x 7.4

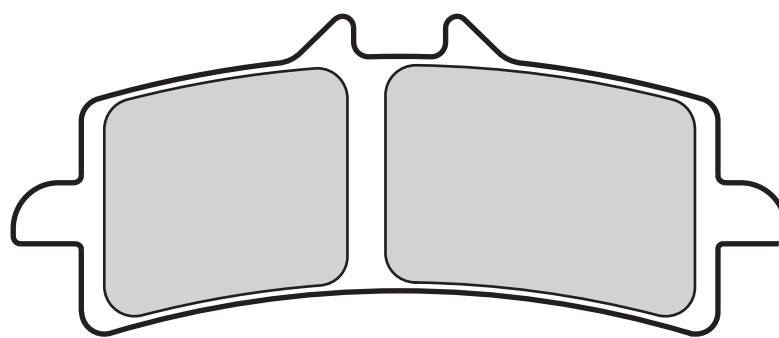

### BMW

1200 HP2 Sport	08->	●	-
----------------	------	---	---

### DUCATI

990 DESMOSEDICI RR (D16RR)	07->	●	-
1099 1098	07->	●	-

1099 1098 S	07->	●	-
1099 1098 S Tricolore	07->	●	-
1100 HYPERMOTARD S	07->	●	-

### KTM

1190 RC8	08->	●	-
----------	------	---	---

### MV AGUSTA

1078 BRUTALE RR	08->	●	-
1078 F4 RR 312	08->	●	-





**07GR0101** 31.2 x 49.0 x 5.6

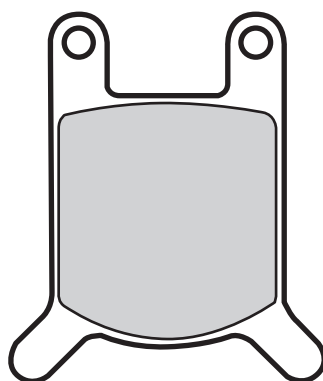

### ASTRO

ATV		•	-
-----	--	---	---

### BENELLI

250 254	83	•	-
---------	----	---	---

### BETA

50 MG	83	•	-
50 SQUIRREL	83	•	-

### CASAL

50 RZ		•	-
-------	--	---	---

### FANTIC MOTOR

50 SUPER SIX	83	•	-
--------------	----	---	---

### GARELLI

40 S SPORT		•	-
80 SPORT	83	•	-

### HERCULES

50 RS	79->83	•	-
50 ULTRA	79->83	•	-
80 AC CHOP	81->83	•	-
80 CHOPPER	81	•	-
80 ULTRA	81	•	-
80 ULTRA CHOPPER AC	81->83	•	-
80 RX 9	82->83	•	-
80 RX 9 air cooled	82->83	•	-



### HOREX

80 REBELL N		•	-
80 REBELL T	86	•	-
80 SPORT L	86	•	-

### MALAGUTI

25 CHOPPER	86	•	-
40 CHOPPER	83	•	-
50 FIFTY HF WC	83	•	-
50 RONCO	83	•	-
50 SPORT XL	83	•	-
50 V4 OLIPIQUE	83	•	-
80 CHOPPER	83	•	-
125 RUNNER	86	•	-

### MALANCA

ENDURO MARK ST 54		•	-
GT 55		•	-

### MOTO GUZZI

125 T	81	•	-
-------	----	---	---

### MOTRON

SV 3/RID		•	-
----------	--	---	---

### OSSA

350 TU-YO		•	-
-----------	--	---	---



### PUCH

50 COBRA 6 GT, GTL	80	•	-
50 MONZA 4 SL, GSL	80	•	-

### REAL

80 NEVADA SPORT		•	-
-----------------	--	---	---

### RIEJU

80 NEVADA SPORT		•	-
-----------------	--	---	---

### SACHS

80 LOTUS SA		•	-
UFO			
PREMIER X 12		•	-

### ZÜNDAPP

50 KS TT	80->81	•	-
50 KS SUPER SPORT	79	•	-
80 KS TOURING	80	•	-
80 KS SUPER	83	•	-
175 KS	78	•	-

### ZWEIRAD ROTH

50 REBEL SPORT		•	-
80 REBEL SPORT		•	-





**07GR0204** 49.0 x 58.0 x 7.1

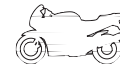
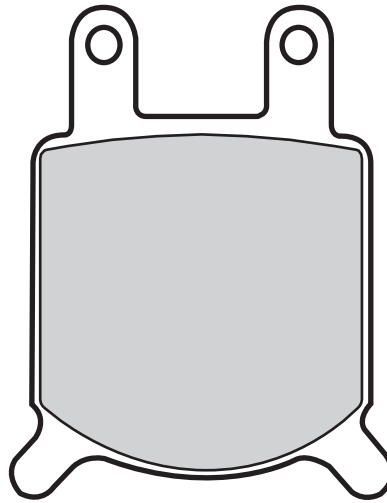

### ASPES

125 JUMA	76	•	-
----------	----	---	---

### BETA

125 TS, CUSTOM	83	•	-
250 CUSTOM	82	•	-

### FANTIC MOTOR

125 SPORT HP1	86	•	-
---------------	----	---	---

### GARELLI

125 TSR	83	•	-
125 GTA	86	•	-

### GILERA

80 TG1	83	•	-
125 GR1	85	•	-
125 RV	86	•	-
125 TG1	85	•	-
200 T4, T4C, T4S	85	•	-
200 RV	86	•	-

### KREIDLER

125 MUSTANG	83	•	-
-------------	----	---	---

### LAVERDA

125 125	80	•	-
---------	----	---	---

### MOTO MORINI

125 STRADA		•	-
250 STRADA		•	-
250 TT	86	•	-
350 K2	84	•	-
350 SPORT	80	•	•
350 STRADA		•	-
350 TT	80	•	-
500 STRADA		•	-
500 TT	80	•	-

### ZÜNDAPP

80 KS	80	•	-
125 KS	79->81	•	-



**07GR1001** 43.4 x 64.4 x 7.0

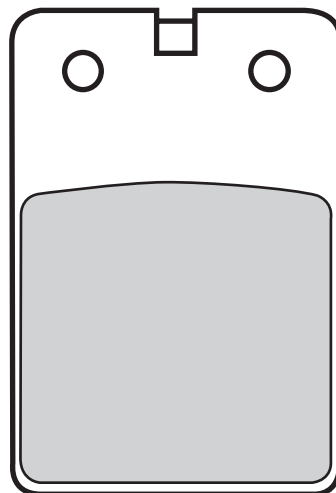

### FANTIC MOTOR

125	84	•	-
125 SPORT	84->85	•	-

### GILERA

125 RV	83	•	-
200 RV	85->86	•	-

### MOTO MORINI

400 S	84	•	-
500 6 V CLASSIC	89	•	-
3.1/2LVS KLASSIK	86	•	-





**07GR1406** 76.5 x 41.9 x 7.3

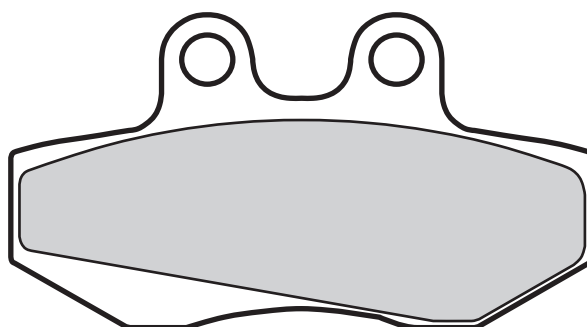

### APRILIA

50	RX	08->	●	-
125	CLASSIC	96	●	-
125	PEGASO	90->91	●	-
125	RED ROSE	90	●	-
125	TUAREG RALLY	92	●	-
125	TUAREG WIND	89	●	-
125	TUAREG WIND	90	●	-
600	PEGASO	90	●	-

### BETA

50	PRO RACE	98	●	-
50	RR ENDURO	99	●	-
50	RR STANDARD	99	●	-
50	RR SUPERMOTARD	99->03	●	-

### BULTACO

50	LOBITO	99	●	-
50	ASTRO	01	●	-

### DERBI

50	GPR	98	●	-
50	SENDAR	03->04	●	-
125	ATMOSPHERE	99	●	-
180	PREDATOR	99	●	-

### GAS GAS

50	EC ROOKIE	01->04	●	-
50	SM ROOKIE	01	●	-

### GILERA

125	RUNNER FX	98	●	-
150	RUNNER FX	97	●	-
180	RUNNER FXR	98	●	-
200	FX RUNNER	97->98	●	-

### HRD

50	GS ENDURO	00	●	-
50	SONIC	00	●	-
50	SONIC TRIAL	00	●	-
125	SUPERMOTARD	00	●	-
125	TRIAL	00	●	-

### HUSQVARNA

50	SM	02	●	-
50	WR	02	●	-

### ITALJET

50	SM	02	●	-
125	SM	02	●	-

### PEUGEOT

50	XR6	02	●	-
----	-----	----	---	---

### RIEJU

50	MRX PRO	05	●	-
50	RACING	01	●	-
50	RS2 MATRIX	03	●	-
50	SMX	02	●	-
50	SPIKE (AJP caliper)	02	●	-
50	SPIKE	02	●	-
125	MRX	03	●	-
125	SMX	03	●	-

### SHERCO

50	SM, ENDURO	02	●	-
125	125	02	●	-
125	CITY CORP 4T ENDURO	03	●	-
125	CITY CORP 4T SM	03	●	-

### SIAMOTO

125	BD	02	●	-
-----	----	----	---	---

### SIMSON

125	SM	01	●	-
-----	----	----	---	---

### YAMAHA

125	XT X SUPERMOTARD	05	●	-
-----	------------------	----	---	---





**07GR1506** 99.6 x 46.9 x 7.4

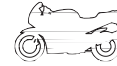
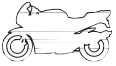
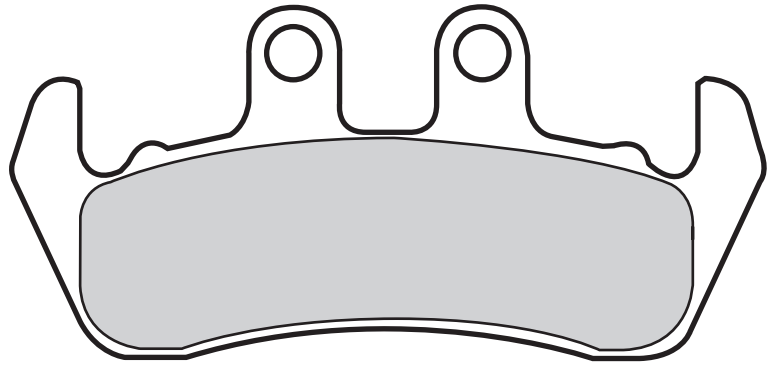

### YAMAHA

125	DT TENERE SCOUT	90	•	-
125	DTZ TENERE	90	•	-



**07GR1705** 55.4 x 46.4 x 6.0

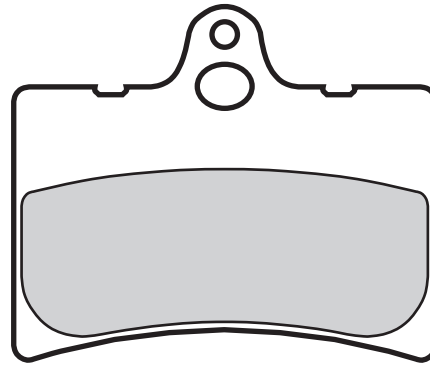

### BENELLI

50	DEVIL	92	•	-
50	SPRING	92	•	-

### BETA

TR 34	92	•	-
TR 36	92	•	-

### CAGIVA

80	PRIMA	92	•	-
125	PRIMA	92	•	-

3





**07GR2106** 87.1 x 53.0 x 7.4

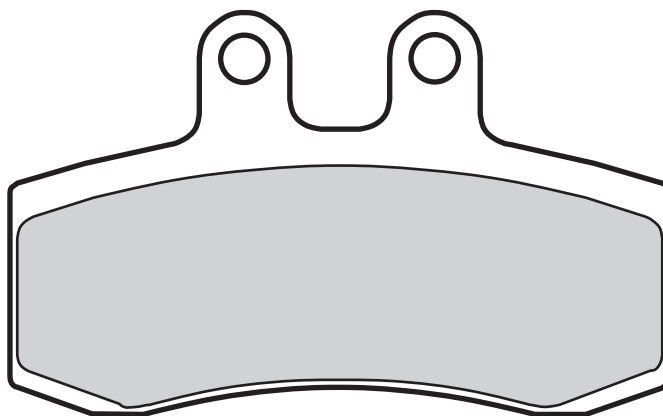

### APRILIA

650	PEGASO	92->95	•	-
-----	--------	--------	---	---

### MZ

125	SM, SX	99->01	•	-
660	BAGHIRA MUZ	96	•	-
660	BLACK PANTHER MUZ	00	•	-
660	MASTIFF MUZ	00	•	-
660	STREET MOTO MUZ	00	•	-

3



**07GR35SP** 69.4 x 42.5 x 7.5  
Sintered

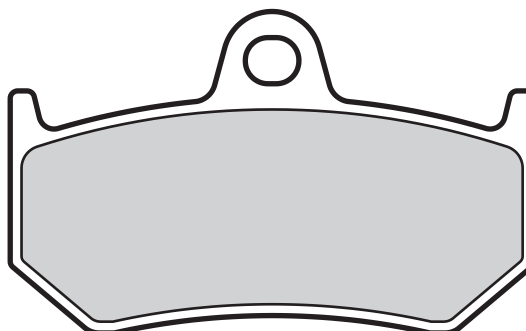

### MV AGUSTA

750	BRUTALE	03->	-	•
750	BRUTALE AMERICA	04->	-	•
750	BRUTALE GLADIO	05->	-	•
750	BRUTALE ORO	02->	-	•
750	BRUTALE S	02->	-	•
750	BRUTALE MAMBA	05->	-	•
750	F4	00->04	-	•

750	F4 AGO	03->	-	•
750	F4 SPR	03->	-	•
910	BRUTALE S	04->	-	•
910	BRUTALE R	06->	-	•
989	BRUTALE R	08->	-	•
1000	F4 MAMBA	03->	-	•
1000	F4 CORSE	05->	-	•
1000	F4 R 312	07->	-	•

1000	F4 R, R 1+1	06->	-	•
1000	F4 S, 1+1	04->	-	•
1000	F4 SENNA	06->	-	•
1000	F4 TAMBURINI	04->	-	•
1078	BRUTALE RR	08->	-	•
1078	F4 CC	08->	-	•
1078	F4 RR 312	08->	-	•





**07GR4804** 35.6 x 38.5 x 6.0

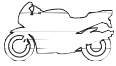
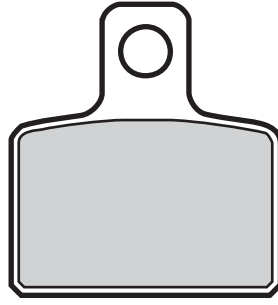

### APRILIA

50	MINI RX	04->	●	-
----	---------	------	---	---

### BETA

50	PRO RACE	04->	●	●
----	----------	------	---	---

### GAS GAS

125	TXT	04->	-	●
200	TXT	04->	-	●
250	TXT	04->	-	●
280	TXT	04->	-	●
300	TXT	04->	-	●



### HONDA

250	COTA 4 RT	05->	-	●
-----	-----------	------	---	---

### HUSQVARNA

50	CR JUNIOR	06->	●	-
50	CR PRO SENIOR	06->	●	-
50	CR SENIOR	06->	●	-

### MONTESA

250	COTA 4RT	05	-	●
360	315R	01->04	-	●

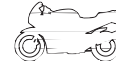

### SCORPA

115	SY F TRIAL	06	-	●
115	TY-S F TRIAL	06	-	●
125	SY F TRIAL	06	-	●
125	TY-S F TRIAL	06	-	●
250	SY F TRIAL	06	-	●
250	SY TRIAL	00	-	●

### SHERCO

250	2.5	01	-	●
290	2.9	01	-	●
320	3.2 4T	05	-	●







**07GR49SD** 62.0 x 40.7 x 9.5  
82.2 x 40.7 x 9.5  
Sintered

**07GR49SX** 62.0 x 40.7 x 9.5  
82.2 x 40.7 x 9.5  
Sintered

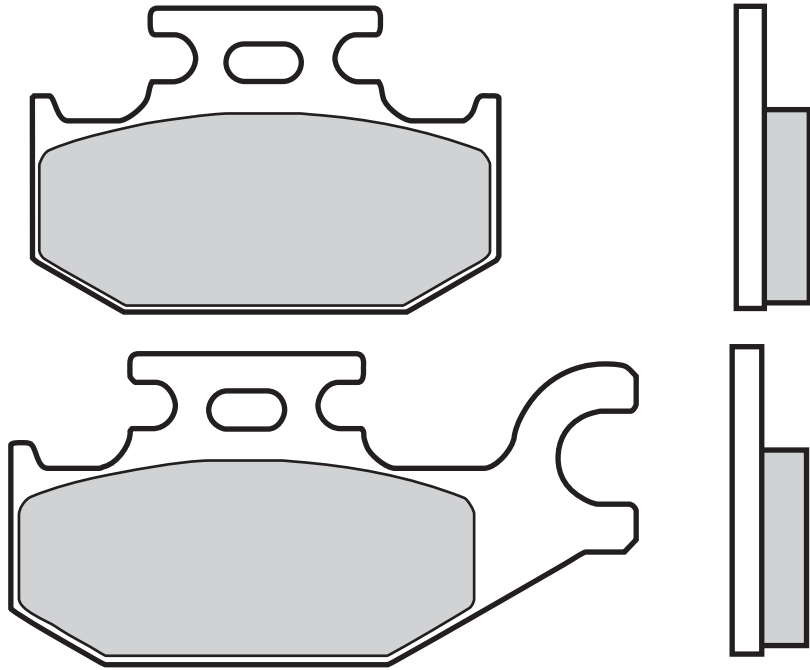

### BOMBARDIER

250	DS	06->	●	●
330	Outlander	03->	●	●
400	Outlander	03->	●	●
400	Outlander Max	03->	●	●
500	Quest	02->	●	●
500	Traxter 4x4	01->	●	●
500	Traxter Max	03->05	●	-
650	Quest (Quest/EBE)	02->	●	●
650	Quest Max	03->	●	-



650	Traxter Max	03->05	●	-
650	DS (DS650/EBE)	01->	●	●
800	Outlander	06->	●	●
800	Outlander XT	06->	●	●

### CANNONDALE

440	Blaze	03->	●	●
440	Cannibal	03->	●	●
440	Glamis	03->	●	●
440	Moto	03->	●	●
440	Speed	03->	●	●



### YAMAHA

400	XT	86	-	●
400	YFM FAM Kodiak	00->	-	●
400	YFM FWN Big Bear 4WD	00->	-	●
400	YFM FWNH Big Bear-Buckmaster 4WD	00->	-	●
400	YFM N Big Bear 2WD	00->	-	●
450	YFM FA Kodiak	03->	-	●
450	YFM Wolverine	06->	-	●
450	YFM KODIAK	03	-	●





**07GR50SD** 62.0 x 40.7 x 9.5  
82.2 x 40.7 x 9.5  
Sintered

**07GR50SX** 62.0 x 40.7 x 9.5  
82.2 x 40.7 x 9.5  
Sintered

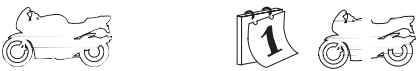
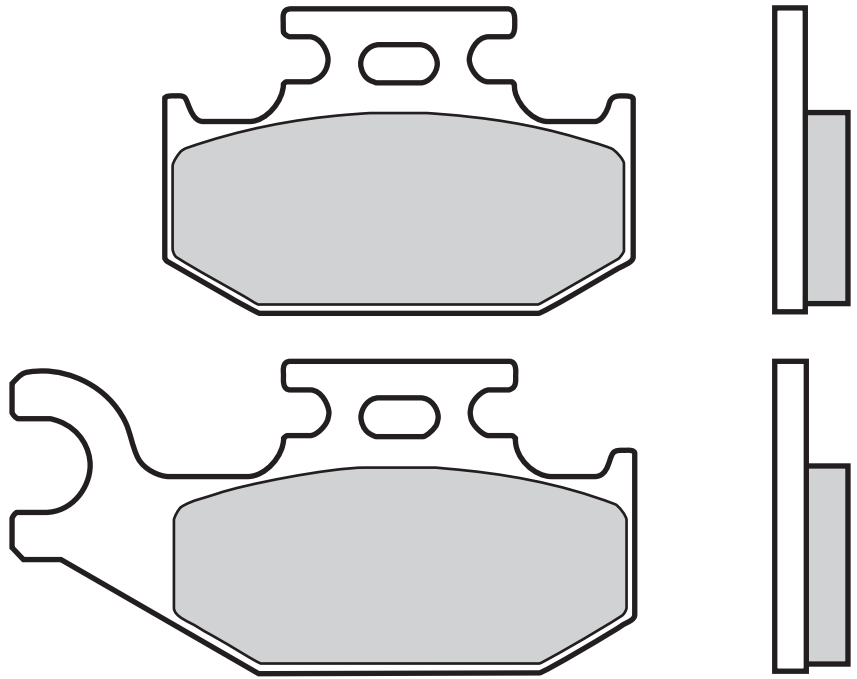

### BOMBARDIER

250	DS	06->	●	-
330	Outlander	03->	●	-
400	Outlander Max	03->	●	-
400	Outlander	03->	●	-
500	Quest	02->	●	-
500	Traxter 4x4	01->	●	-
500	Traxter Max	03->05	-	●



500	Traxter Max	03->05	●	-
650	DS Right (DS650/EBE)	01->	●	-
650	Quest Max	03->	-	●
650	Quest Max	03->	●	-
650	Quest (Quest/EBE)	02->	●	-
650	Traxter Max	03->05	-	●
650	Traxter Max	03->05	●	-
800	Outlander	06->	●	-
800	Outlander XT	06->	●	-



### CANNONDALE

440	Blaze	03->	●	-
440	Cannibal	03->	●	-
440	Glamis	03->	●	-
440	Moto	03->	●	-
440	Speed	03->	●	-



**07GR5105** 56.4 x 43.5 x 6.6

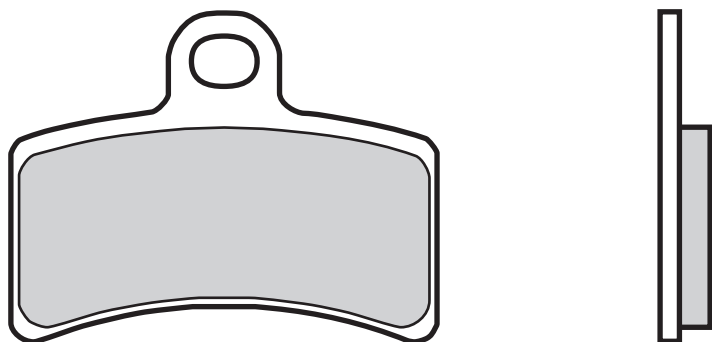

### GAS GAS

50	EC BOY	01->	●	●
50	EC ROOKIE	01->04	-	●



50	TXT BOY	01->03	●	●
50	TXT ROOKIE	02->03	●	●
50	SM ROOKIE	01	-	●
65	MC	05	●	●



80	TXT ROOKIE	02->03	●	●
125	PAMPERA	04	-	●
250	PAMPERA	02->	-	●
280	PAMPERA	04->	-	●





**07GR5209** 94.0 x 47.0 x 8.7  
73.0 x 47.0 x 10.7

**07GR52SD** 94.0 x 47.0 x 8.7  
73.0 x 47.0 x 10.7  
Sintered

**07GR52SX** 94.0 x 47.0 x 8.7  
73.0 x 47.0 x 10.7  
Sintered

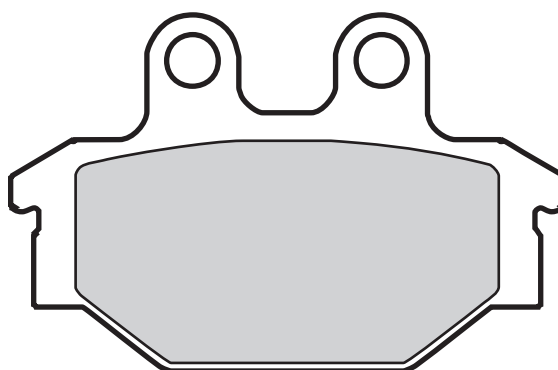
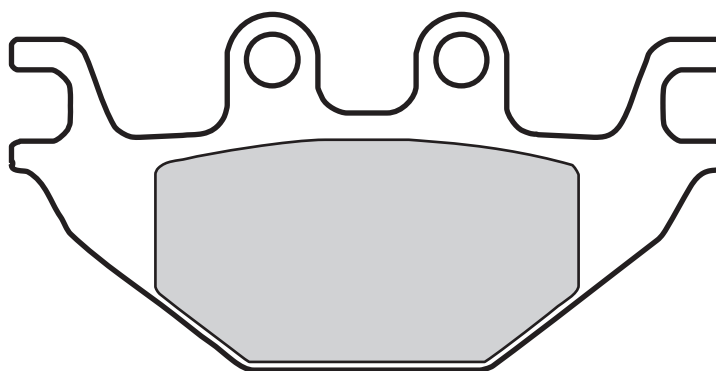

3



### ADLY

300	ATV Sport	07->	●	-
300	Cross X Over	07->	●	-
300	Cross X Road	07->	●	-
320	S	07->	●	-
320	U	07->	●	-



### CPI

250	XS ATV	07->	●	-
-----	--------	------	---	---

### HERCULES

280	ATV	07->	●	-
-----	-----	------	---	---

### KYMCO

250	KXR	04->	●	-
250	MXU	06->	●	-
250	Urban Quad	06->	●	-
250	KXR (L3/e4/0235)	04->	●	-
300	MAXXER	06->	●	-
300	MXU	06->	●	●
500	MXU	06->	●	●



### SYM

200	TRACKRUNNER	06->	●	●
250	QUADLANDER	06->	●	-
300	CITY MAX	06->	●	-
300	QUADLANDER	06->	●	●
600	QUAD RAIDER	08->	●	●





**07GR53SD** 94.5 x 45.5 x 7.0

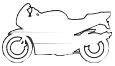
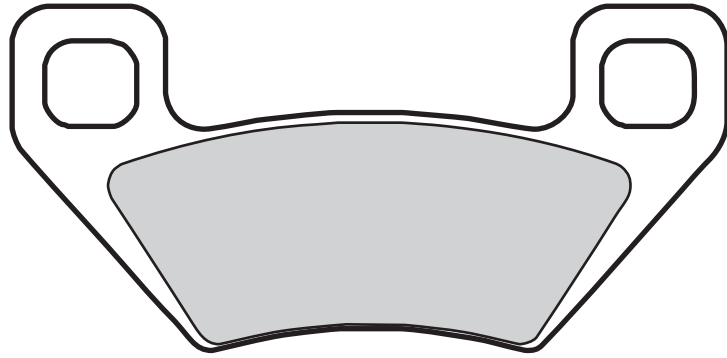

### ARCTIC CAT

250	2x4	05->	•	•
300	4x4	05->	•	•
400	2x4/4x4 (FIS)	05->	•	•
500	2x4/4x4 (FIS)	05->	•	•
500	TBX 4x4	05->	•	•

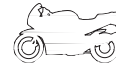

500	TRV 4x4	05->	•	•
650	H1 4x4 Aut.	05->	•	•
650	V2 4x4 Aut.	05->	•	•
650	V2 4x4 Aut. LE	05->	•	•



**07GR54SD** 67.6 x 44.0 x 7.7  
Sintered

**07GR54SX** 67.6 x 44.0 x 7.7  
Sintered

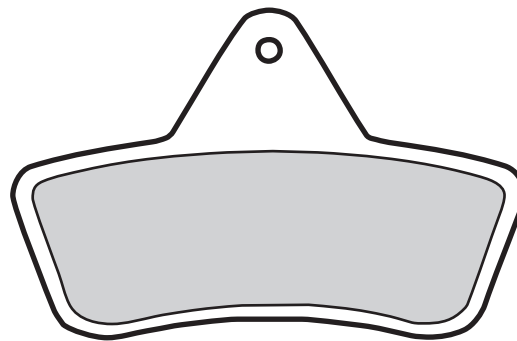

### ARCTIC CAT

	Bear Cat	96->97	-	•
250	2x4/4x4	99->04	•	•
300	2x4/4x4	98->04	•	•
375	2x4/4x4	02	•	•
400	2x4/4x4	98->04	•	•



400	2x4/4x4 (FIS)	02->04	•	•
400	TBX 4x4	04	•	•
454	Arctic Cat 4x4	98	•	•
454	Bear Cat 2x4/4x4	96->98	•	•
500	2x4/4x4	98->04	•	•
500	2x4/4x4 (FIS)	02->04	•	•
500	TBX 4x4	02->04	•	•
500	TRV 4x4	03->04	•	•

### LAVERDA

125	HP QUASAR	04->	-	•
180	HP QUASAR	04->	-	•
400	QUASAR 4X4	04->	•	•
500	QUASAR 4X4	04->	•	•
500	QUASAR 4X4 C	04->	•	•

3





**07GR55SD** 43.2 x 25.4 x 8.4  
Sintered



### ARCTIC CAT

250	2x4 (Man. Hand Brake)	99->	-	●
250	4x4 (Man. Hand Brake)	00->	-	●
300	2x4 (Man. Hand Brake)	98->04	-	●
300	4x4 (Man. Hand Brake)	98->	-	●
375	2x4/4x4 (Man. Hand Brake)	02	-	●
400	2x4 (Man. Hand Brake)	98->02	-	●
400	2x4/4x4 (FIS) Aut. (Man. Hand Brake)	03->04	-	●



400	2x4/4x4 (FIS) (Man. Hand Brake)	02->04	-	●
400	4x4 (Man. Hand Brake)	98->04	-	●
400	TBX 4x4 (Man. Hand Brake)	04	-	●
454	Bear Cat 2x4/4x4 (Man. Hand Brake)	98	-	●
500	2x4 (FIS) (Man. Hand Brake)	02	-	●
500	2x4 (Man. Hand Brake)	02	-	●
500	4x4 (FIS) Aut. (Man. Hand Brake)	02->03	-	●



500	4x4 (FIS) (Man. Hand Brake)	02->03	-	●
500	4x4 (Man. Hand Brake)	98->02	-	●
500	TBX 4x4 (Man. Hand Brake)	03->04	-	●
500	TBX 4x4 Aut. (Man. Hand Brake)	02	-	●
500	TRV 4x4 (Man. Hand Brake)	03->04	-	●

3



**07GR5605** 67.4 x 50.9 x 7.0

**07GR56SA** 67.4 x 50.9 x 7.0  
Sintered

**07GR56SC** 67.4 x 50.9 x 7.0  
Sintered

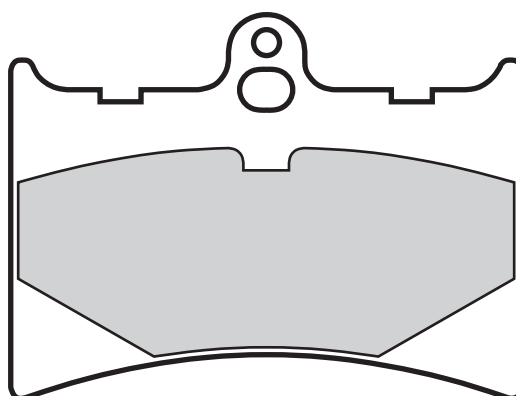

### ALFER

125	MC	88	●	-
250	GR ENDURO	88	●	-
250	MC	88	●	-
300	GR ENDURO	88	●	-

### APRILIA

125	AF1 REPLICA, SINTESI	88->89	●	-
125	AF1 FUTURA, EUROPA	89->91	●	-
125	RS	99->05	●	-
125	RS, EXTREMA	93->98	●	-
125	RS PISTA	04->05	●	-
125	SPORT PRODUCTION	92	●	-
125	TUONO	04	●	-



### ASPES

125	SINTESI	88	●	-
-----	---------	----	---	---

### BENELLI

125	BX	89	●	-
125	JARNO	89	●	-

### GILERA

125	CHRONO	91	●	-
125	CX	91	●	-
125	FREESTYLE	92	●	-
125	MX1	88	●	-
125	SP 01, SP 02	89	●	-
600	NORDWEST	90	●	-



### KTM

125	MX, GS	87	●	●
250	GS	87	●	●
250	MX	87	●	●
500	MX	87	●	●
600	MC, LC4, ENDURO	88	●	●

### MOTO GUZZI

1000	QUOTA	92->95	●	-
------	-------	--------	---	---

### MZ

660	SKORPION SPORT MUZ	95->99	●	-
660	SKORPION TOUR MUZ	95->99	●	-
660	SKORPION TRAVELLER MUZ	99	●	-

### TM

125	CROSS, ENDURO	89->90	●	-
125	CROSS, ENDURO	91	●	-





**07GR5705** 75.0 x 40.3 x 6.7

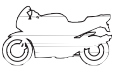
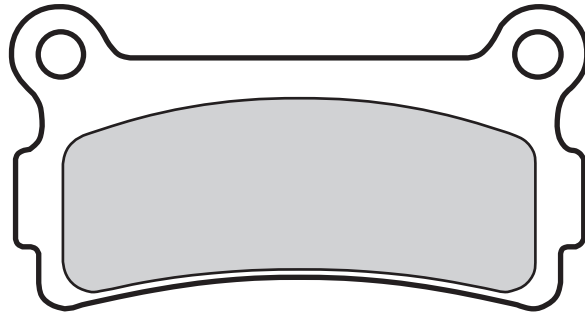

### BETA

SR 34	89	-	•
TR 34	92	-	•
TR 36	92	-	•
50 MX ENDURO	92	-	•



50 SUPER TRIAL	92	-	•
125 TRIAL	97	-	•
240 SUPER TRIAL	92	-	•
240 ALP	92->95	-	•
240 ALP	96	-	•
250 ALP	92->96	-	•

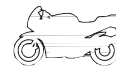

250 ZERO	91	-	•
260 SYNT	92	-	•
260 ZERO	91	-	•



**07GR5804** 49.6 x 43.4 x 6.0

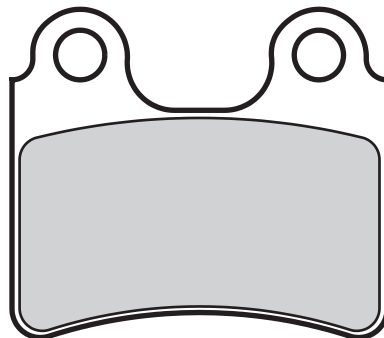

### BETA

125 REV 3	00	•	•
250 REV 3	00->	•	•
270 REV 3	00->	•	•

### GAS GAS

50 EC ROOKIE	05	-	•
125 TXT	04->	•	-
200 TXT	04->	•	-
250 TXT	04->	•	-
280 TXT	04->	•	-
300 TXT	04->	•	-



### MONTESA

250 COTA 4RT	05	•	-
360 315R	01->04	•	-

### SCORPA

115 SY F TRIAL	06	•	-
125 SY F TRIAL	06	•	-
125 TY-S F TRIAL	06	•	-
250 SY TRIAL	00	•	-
250 SY F TRIAL	06	•	-

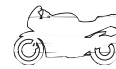

### SHERCO

250 2.5	01	•	-
290 2.9	01	•	-
320 3.2 4T	05	•	-





**07GR5915** 71.6 x 34.9 x 9.4/13.0

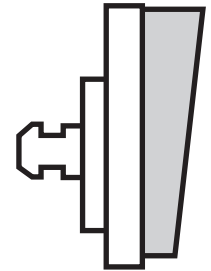
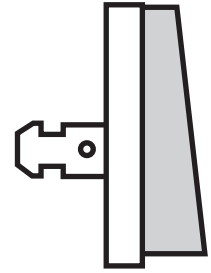
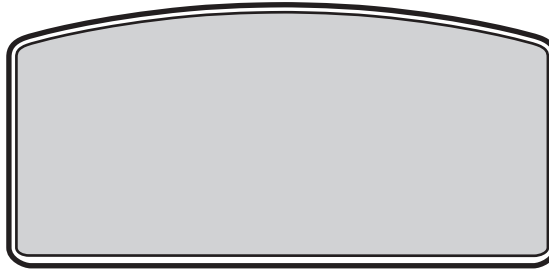

**BMW**

600 R 60/7	76->78	●	-
750 R 75/6	74->76	●	-
750 R 75/7	76->77	●	-



800 R 80/7	77->78	●	-
800 R 80/7	79->81	●	-
900 R 90/6	73->76	●	-
900 R 90 S	73->76	●	-
1000 R 100/7	76	●	-



1000 R 100 S	76->77	●	-
1000 R 100 S	78->80	●	-
1000 R 100 T	79	●	-
1000 R 100 RS	76->80	●	-
1000 R 100 RT	79->80	●	-

3



**07GR6007** 55.6 x 52.8 x 9.0

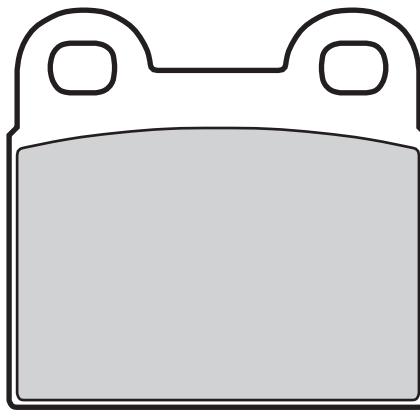

**BMW**

450 R 45	78->80	●	-
650 R 65	78->80	●	-
1000 R 100 CS	81->83	●	-
1000 R 100 RS	81->83	●	-
1000 R 100 RT	81->83	●	-

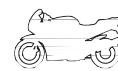



**07GR6207** 81.0 x 45.9 x 9.0

**07GR62SA** 81.0 x 45.9 x 9.0  
Sintered

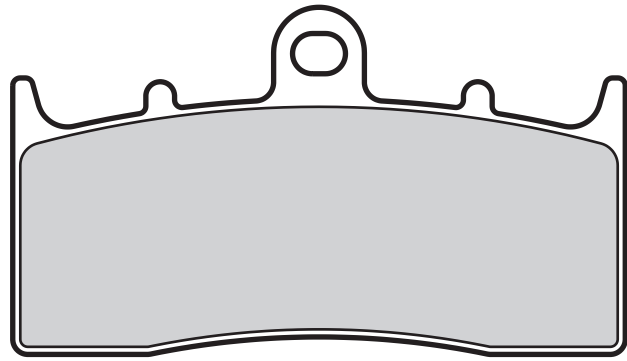

### BMW

850 R 850 R	03	•	-
1100 R 1100 S ABS	01	•	-
1150 R 1150 R	01->	•	-



1150 R 1150 R ROCKSTER	02	•	-
1150 R 1150 RS	01	•	-
1150 R 1150 S	03	•	-
1200 K 1200 LT ABS	01->	•	-
1200 K 1200 R	05	•	-

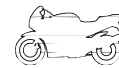

1200 K 1200 R	07->	•	-
1200 K 1200 R Sport	07->	•	-
1200 R 1200 CL	03	•	-
1200 R 1200 R	07->	•	-



**07GR6319** 44.5 x 43.2 x 10.0  
44.7 x 47.4 x 10.2

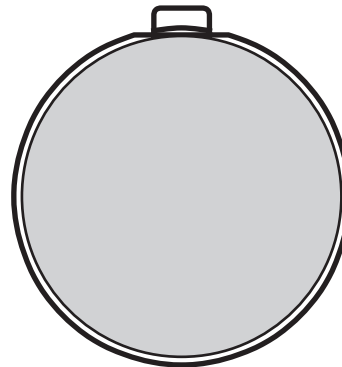
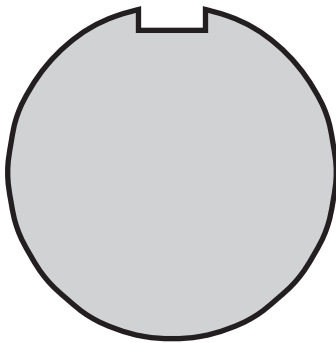

### HYOSUNG

125 CRUISE II, CLASSIC	99	•	-
125 F	00	•	-
125 GA, GA F	98	•	-
125 GS	99	•	-



### SUZUKI

125 GP all models	77	•	-
-------------------	----	---	---







**07GR6407** 78.9 x 45.9 x 9.0

**07GR64TT** 78.9 x 45.9 x 9.0

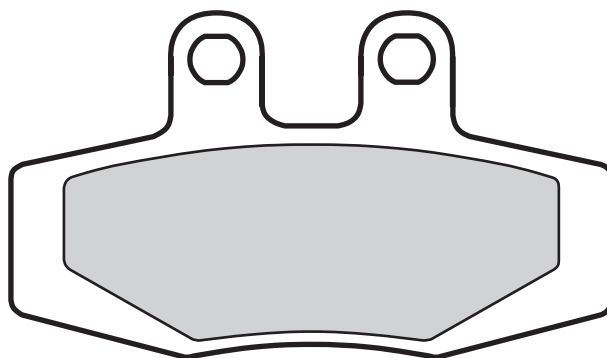

### KTM

MODELLI ENDURO		91	•	•
125	EXC	90	•	•
125	MX, GS	88	•	•
125	GS	89->91	•	•
250	EXC	90->91	•	•
250	GS	88->93	•	•
250	MX	88	•	•
300	EXC	90->92	•	•
350	EXC	87	•	•



350	EXC	88	•	•
350	EXC	90->91	•	•
350	GS	87	•	•
350	GS	88	•	•
350	MX	87	•	•
350	MX	88	•	•
500	MX	88	•	•
550	LC4	87	•	•
550	MX	87	•	•
600	EXC	87	•	•
600	EXC	88	•	•



600	INCAS	89	•	•
600	MX	87	•	•
600	MX	88	•	•

### MAICO

250	GP	89	•	•
400	GP	89	•	•
500	GP	89	•	•

3



**07GR6527** 44.4 x 45.6 x 16.0

44.4 x 45.6 x 10.0

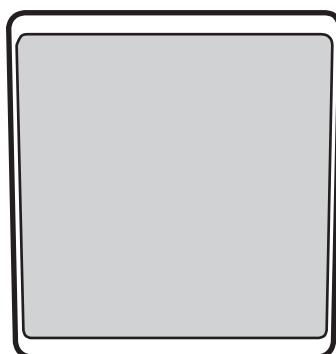

### KAWASAKI

90	KH	78	•	-
100	KH EX,G	81->82	•	-
400	KZ	78->79	•	-





**07GR6610** 59,5 x 52,0 x 10,4

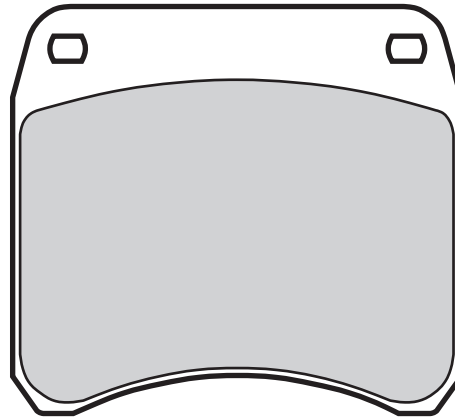

### TRIUMPH

750	BONNEVILLE T 140 V, E	75->81	•	•
750	BONNEVILLE T 140 V,E	81->83	•	•
750	THUNDERBIRD TR 65	81	•	-
750	TIGER TR7 V	73->81	•	•
750	TIGER TR7 R TRIAL	81	•	-
750	TRIDENT T 160 V	75->77	•	•
750	TSS	82	•	•
750	TSX	82	•	•

3



**07GR68SA** 91.6 x 48.5 x 7.9  
Sintered

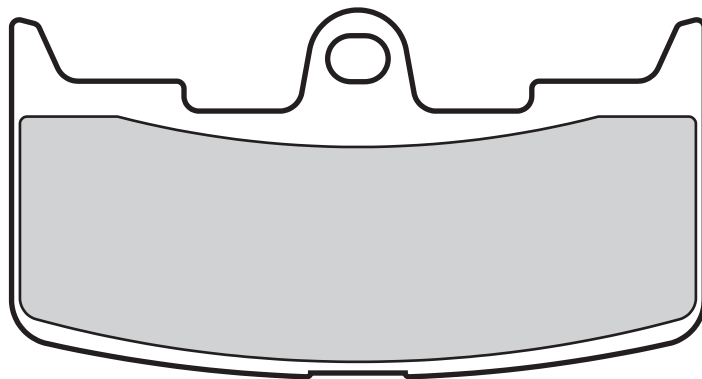

### BUELL

984	XB 8 R	02	•	-
984	XB 8 S	03	•	-
984	XB 9 SX CITY X	05	•	-
1200	XB12 R	04	•	-
1200	XB12 S	04	•	-
1200	XB12 S LIGHTNING LONG	06->	•	-
1200	XB12 X ULYSSES	06->	•	-





**07GR69SD** 61.8 x 31.6 x 6.5  
Sintered

**07GR69SX** 61.8 x 31.6 x 6.5  
Sintered

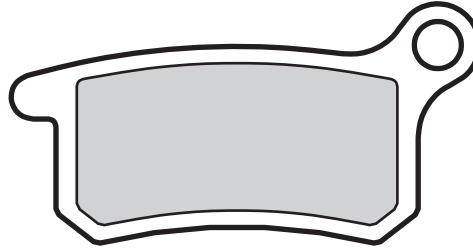
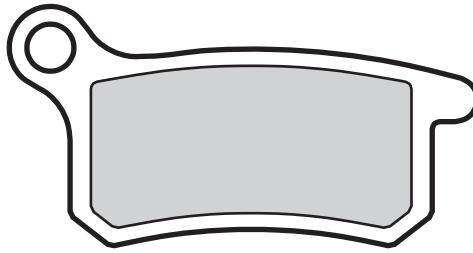

### KTM

65	SX	02->03	•	-
65	SX	04	•	-
85	SX	04	•	•

3



**07GR70SD** 43.3 x 25.0 x 5.0  
Sintered

**07GR70SX** 43.3 x 25.0 x 5.0  
Sintered

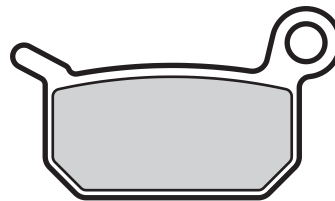
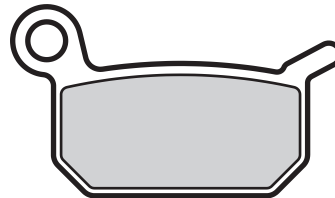

### HUSQVARNA

50	CR PRO SENIOR	06->	-	•
50	CR SENIOR	06->	-	•

### KTM

50	SM SUPERMOTO	06->	•	•
50	SX PRO JUNIOR	02	•	-
50	SX PRO SENIOR	02->03	•	-

50	SX PRO SENIOR	04	•	•
50	SX PRO SENIOR ADVENTURE	04	•	-
65	SX	04	-	•

### LEM

50	R2, R3, R3 XC	03	•	•
----	---------------	----	---	---

### POLINI

50	X1 R	04	•	•
50	X3 R	04	•	•
65	X5 RP	05	•	•





**07GR71SD** 44.6 x 50.7 x 7.0  
Sintered

**07GR71SX** 44.6 x 50.7 x 7.0  
Sintered

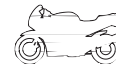
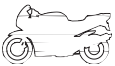
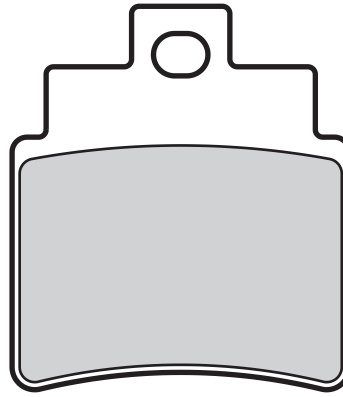

### GILERA

250	Oregon Quad	07->	-	•
-----	-------------	------	---	---

### KYMCO

250	KXR	04->	-	•
250	MXU	06->	-	•
250	Urban Quad	06->	-	•
250	KXR	04->	-	•
300	MAXXER	06->	-	•



**07GR72SA** 69.7 x 51.6x 7.5  
Sintered

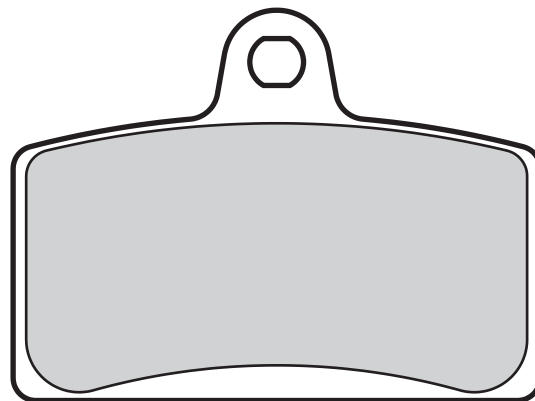

### DERBI

50	DRD PRO R	06->	•	-
50	GPX1	06->	•	-
80	GPR CUP	04->	•	-
125	GPR	05->	•	-
125	GPR NUDE	05->	•	-

### MALAGUTI

50	DRAKON	05->	•	-
50	NKD DRAGON	06->	•	-

### RIEJU

125	TANGO	06->07	•	-
-----	-------	--------	---	---

### GILERA

125	SC	06->	•	-
-----	----	------	---	---





**07GR73SD** 62.0 x 40.7 x 8.3  
82.2 x 40.7 x 8.3  
Sintered

**07GR73SX** 62.0 x 40.7 x 8.3  
62.0 x 40.7 x 8.3  
Sintered

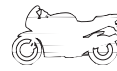
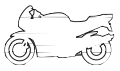
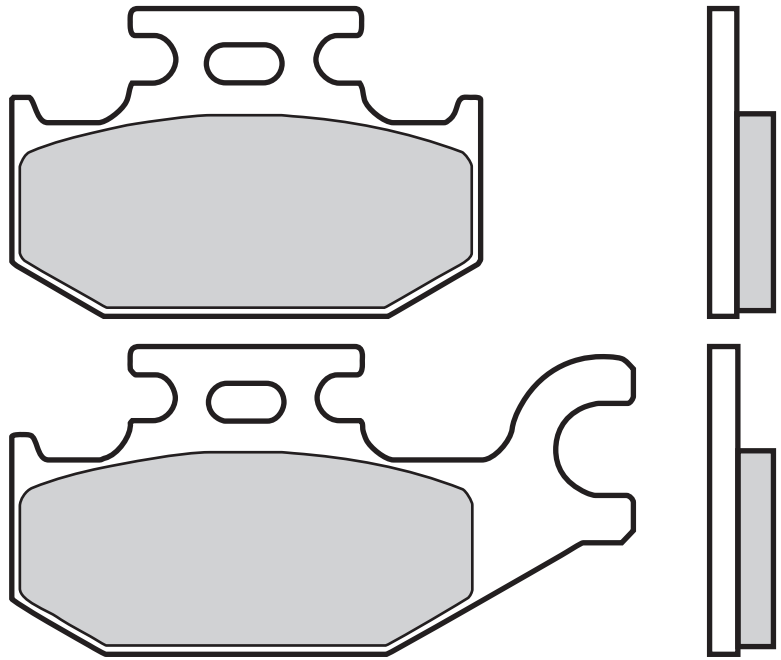

**SUZUKI**

700	LT-A King Quad	05->	•	-
-----	----------------	------	---	---

3



**07GR74SD** 62.0 x 40.7 x 8.3  
82.2 x 40.7 x 8.3  
Sintered

**07GR74SX** 62.0 x 40.7 x 8.3  
62.0 x 40.7 x 8.3  
Sintered

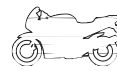
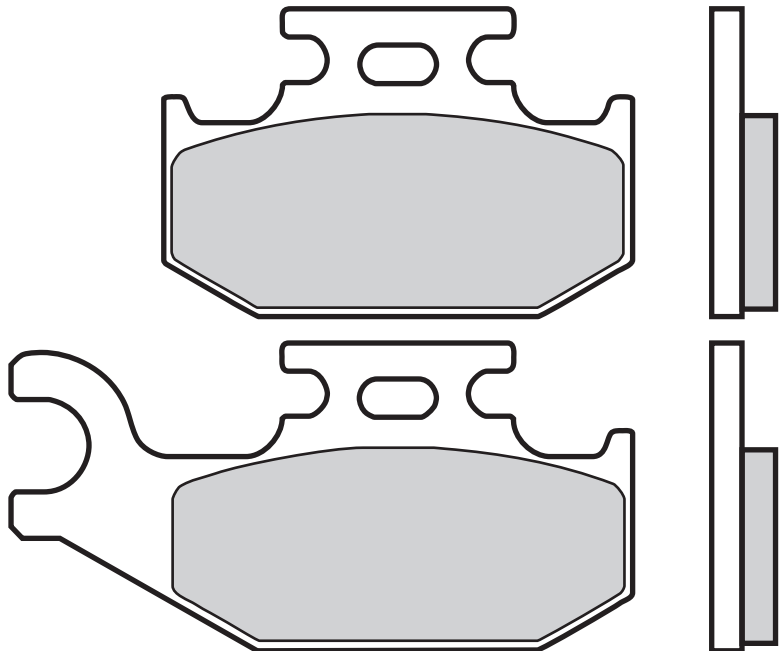

**SUZUKI**

700	LT-A King Quad	05->	•	-
-----	----------------	------	---	---





**07GR75SX** 76.7 x 49.7 x 8.3  
Sintered

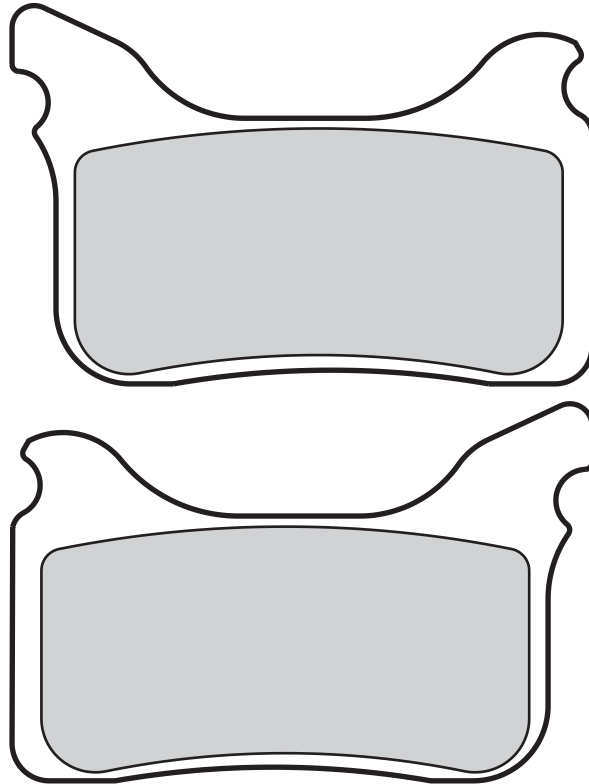

**APRILIA**

450	SXV	06->	•	-
550	SXV	06->	•	-



**KTM**

450	SMR	05->06	•	-
525	SMR	05	•	-

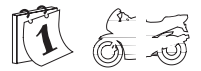

**3**



**07GR76SX** 34.9 x 45.9 x 7.7  
Sintered

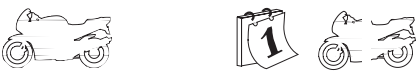
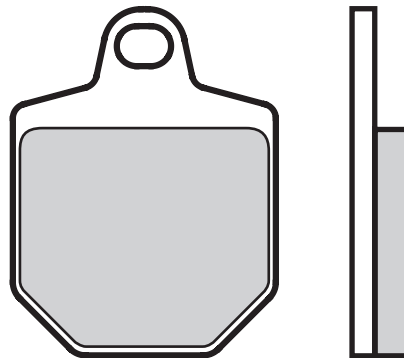

**KTM**

450	SMR	07->	•	-
560	SMR	06->	•	-





**07GR7707** 68.0 x 55.5 x 8.9

**07GR77SA** 68.0 x 55.5 x 8.9

Sintered

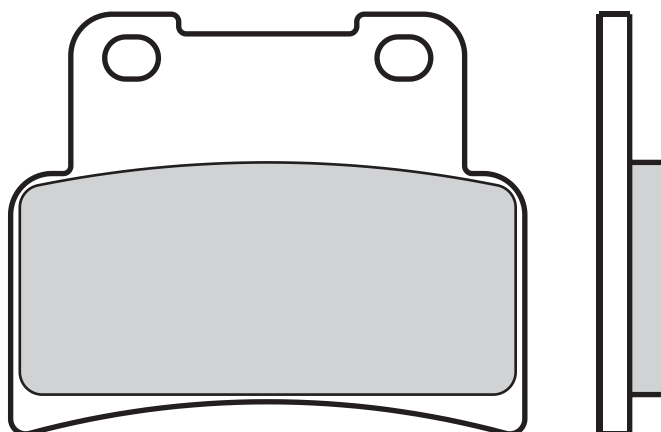

### APRILIA

125	RS	06->	•	-
750	SHIVER	07->	•	-
850	MANA	07->	•	-

3



**07GR78SD** 103.5 x 42.4 x 9.1

62.5 x 34.1 x 11.0

Sintered

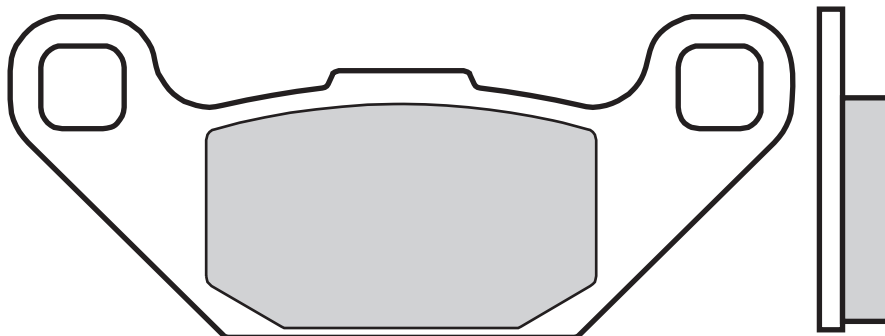
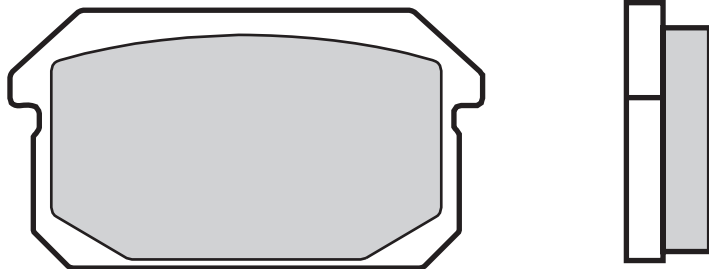

### ADLY

300	ATV Sport	07->	-	•
-----	-----------	------	---	---

### CPI

250	XS Quad	06->	-	•
-----	---------	------	---	---

### QUADZILLA

250	E 250	06->	-	•
250	XRV, E	06->	->	•





**07HD0105** 113.9 x 65.4 x 7.2

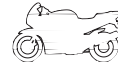
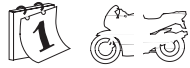
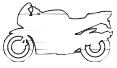
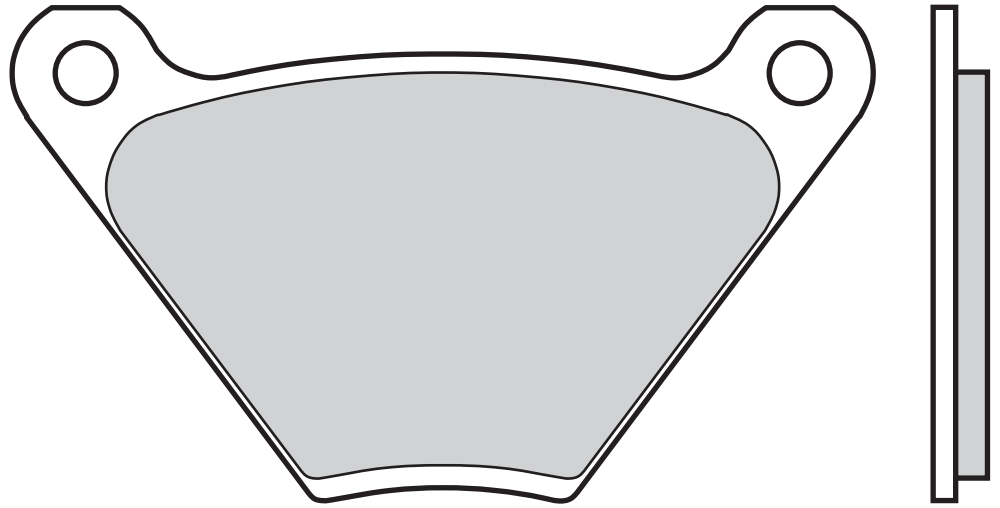

### HARLEY DAVIDSON

FXE Series	74->77	-	●
1000 XLCH	73	●	-
1200 FL FLH Police	75->79	●	●
1200 FLH	74->76	●	●
1200 FLH	80	●	-
1200 FLH Anniversary	78	●	●
1200 FLH Touring	77->78	●	●

1200 FLHS	77->80	●	●
1200 FX	74->80	-	●
1200 FXE	74->80	-	●
1200 FXS	78->79	-	●
1340 FLH 80	78->80	●	●
1340 FLH 80	81	●	-
1340 FLH Electra Glide	82->83	-	●
1340 FLH Electra Glide Spec.	84	●	-
1340 FXB 80	80->81	-	●

1340 FXB Sturgis	82	-	●
1340 FXE 80	78->81	-	●
1340 FXE Super Glide	83->84	-	●
1340 FXEF 80 Fat Bob	79->81	-	●
1340 FXR	78->81	-	●
1340 FXS 80	79->81	-	●
1340 FXS Low Rider	82	-	●
1340 FXWG 80	80->81	-	●
1340 FXWG Wide Glide	82	-	●







**07HD0202** 53.4 x 68.8 x 6.5

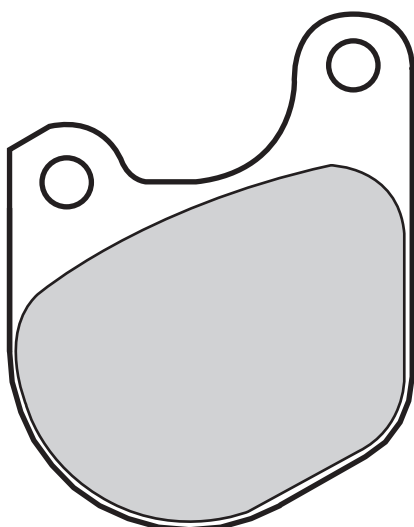

### HARLEY DAVIDSON

883 XLH Sportster	70->83	●	-
1000 XL	78	●	-
1000 XLCH	78->80	●	-
1000 XLH Sportster	79->82	●	-
1000 XLH Sportster	83->85	●	-
1000 XLS Anniversary	82	●	-
1000 XLS Roadster	79->82	●	-
1000 XLS Sportster	83	●	-
1000 XLX 61	83	●	-
1000 XLX 61	84	●	-

1000 XR	85	●	-
1200 FX	74->80	●	-
1200 FXE	74->80	●	-
1200 FXS	78->79	●	-
1340 FLTH Tour Glide	84	●	-
1340 FXB 80	80->81	●	-
1340 FXB Sturgis	82	●	-
1340 FXE	82	●	-
1340 FXE 80	78->81	●	-
1340 FXE Super Glide	83->84	●	-
1340 FXEF 80 Fat Bob	79->81	●	-
1340 FXR	78->81	●	-

1340 FXR Super Glide	82->83	●	-
1340 FXRS Low Glide	82->84	●	-
1340 FXRS Super Glide II	82->83	●	-
1340 FXRT Super Glide II	83	●	-
1340 FXS 80	79->81	●	-
1340 FXS Low Rider	82	●	-
1340 FXSB Low Rider	83	●	-
1340 FXWG 80	80->81	●	-
1340 FXWG Wide Glide	82	●	-
1340 FXWG Wide Glide	83	●	-
1340 FXWG Wide Glide	84	●	-

3





**07HD0303** 88.9 x 71.1 x 6.6

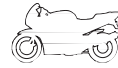
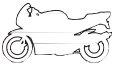
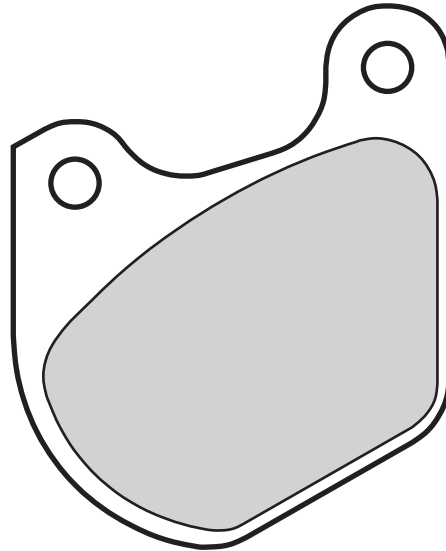

### HARLEY DAVIDSON

1000 XL	78	-	●
1000 XLCH	78->80	-	●
1000 XLH Sportster	79->82	-	●

1000 XLS Roadster	79->82	-	●
1340 FLH Classic	82->83	●	-
1340 FLH Electra Glide	82->83	●	-
1340 FLH Heritage	81	●	-
1340 FLT 80	80->81	●	-

1340 FLT 80 Classic	81	●	-
1340 FLT Classic	82->83	●	-
1340 FLT Tour Glide	82	●	-



**07HD0413** 74.5 x 49.0 x 12.0

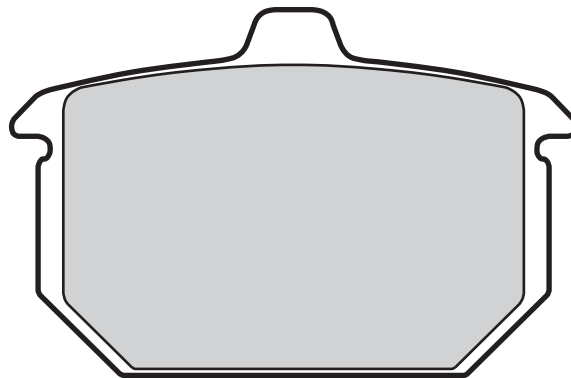

### HARLEY DAVIDSON

883 XLH Sportster	85->86	-	●
1000 XLH Sportster	83->85	-	●
1000 XLS Anniversary	82	-	●
1000 XLS Sportster	83	-	●
1000 XLX 61	83	-	●
1000 XLX 61	84	-	●
1000 XR	85	-	●
1100 XLH Sportster	85->86	-	●

1100 XLX	86	-	●
1340 FLHT Electra Glide	85->86	-	●
1340 FLHTC Electra Glide Classic	85->86	-	●
1340 FLST Heritage Softail	86->87	-	●
1340 FLTC Tour Glide Classic	85->86	-	●
1340 FXE	85->86	-	●
1340 FXR Super Glide	82->83	-	●
1340 FXR Super Glide	85->86	-	●
1340 FXRD Sport Glide GTE	85->86	-	●
1340 FXRS Low Glide	82->84	-	●

1340 FXRS Low Rider	85->86	-	●
1340 FXRS Super Glide II	82->83	-	●
1340 FXRT Sport Glide	85->86	-	●
1340 FXRT Super Glide II	83	-	●
1340 FXSB Low Rider	83	-	●
1340 FXST Softail	84->86	-	●
1340 FXSTC Softail Custom	85->86	-	●
1340 FXWG Wide Glide	83	-	●
1340 FXWG Wide Glide	84	-	●
1340 FXWG Wide Glide	85->86	-	●

3





**07HD0507** 174.3 x 72.8 x 10.4

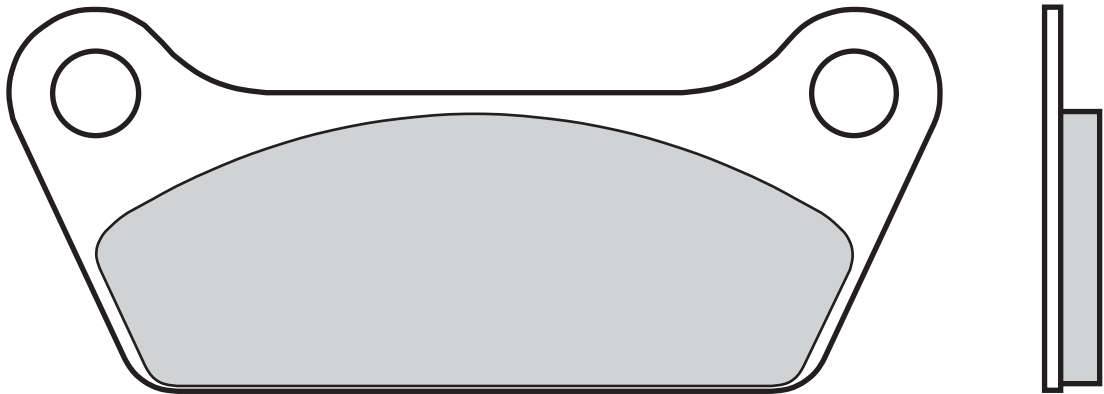

### HARLEY DAVIDSON

1200 FLH	80	-	•
1340 FLH 80	81	-	•
1340 FLH Classic	82->83	-	•

1340 FLH Electra Glide Spec.	84	-	•
1340 FLH Heritage	81	-	•
1340 FLT	84->85	-	•
1340 FLT 80	80->81	-	•
1340 FLT 80 Classic	81	-	•

1340 FLT Classic	82->83	-	•
1340 FLT Tour Glide	82	-	•
1340 FLTH Tour Glide	84	-	•

3



**07HD0614** 59.3 x 61.5 x 13.0

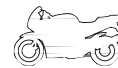
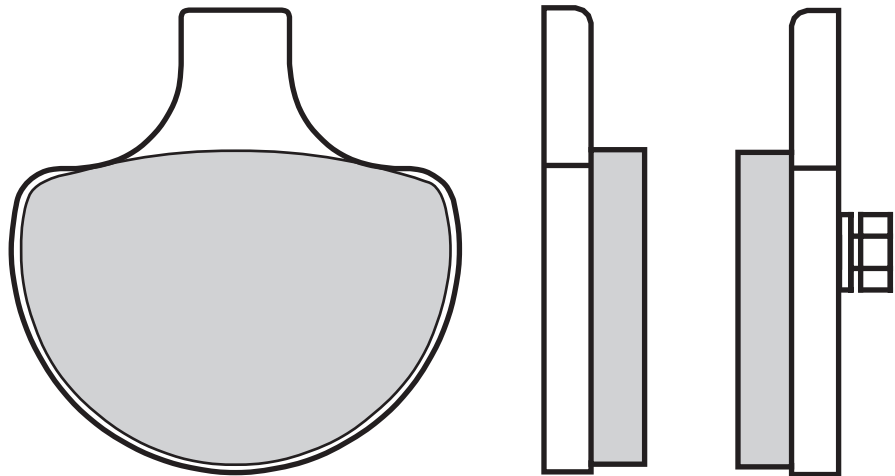

### HARLEY DAVIDSON

FLT Series	88->99	•	-
FLT/H Series	86->87	•	-
XLH Series	88->99	•	-
883 XLH Sportster	85->86	•	-
883 XLH Sportster	87->89	•	-
883 XLH Sportster	90->99	•	-
1100 XLH	87->88	•	-
1100 XLH Sportster	85->86	•	-

1100 XLX	86	•	-
1200 XLH Sportster	90->99	•	-
1340 FLHS Electra Glide Sport	90	•	-
1340 FLHT Electra Glide	85->86	•	-
1340 FLHT Electra Glide Classic	87->99	•	-
1340 FLHTC Electra Glide Classic	85->86	•	-
1340 FLHTC Electra Glide Classic	90->99	•	-
1340 FLHTC Electra Glide Classic	93	•	-
1340 FLHTC Ultra Classic	90->99	•	-
1340 FLST Heritage Softail	86->87	•	-

1340 FLST Heritage Softail	88->99	•	-
1340 FLSTC Heritage Softail Cl.	90->99	•	-
1340 FLSTF Fat Boy	90->99	•	-
1340 FLSTN Heritage Softail Nost.	93->99	•	-
1340 FLT	84->85	•	-
1340 FLTC Tour Glide Classic	85->86	•	-
1340 FLTC Tour Glide Classic	90	•	-
1340 FXDB Dyna Glide Daytona	91->99	•	-
1340 FXDB Dyna Glide Sturgis	91->99	•	-
1340 FXDB Sturgis	91->99	•	-



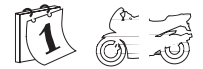
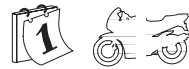
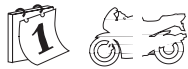
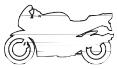

1340 FXDL Dyna Low Rider	93->99	●	-
1340 FXDWG Dyna Wide Glide	93->99	●	-
1340 FXE	85->86	●	-
1340 FXLR Low Rider Custom	87->88	●	-
1340 FXLR Low Rider Custom	93->99	●	-
1340 FXR	87->88	●	-
1340 FXR Super Glide	85->86	●	-
1340 FXR Super Glide	90->99	●	-
1340 FXRD Sport Glide GTE	85->86	●	-
1340 FXRS Low Rider	85->86	●	-
1340 FXRS Low Rider Sport	87->99	●	-
1340 FXRS Low Rider Sport Ed.	90->99	●	-

1340 FXRS Low Rider, Convert.	90->99	●	-
1340 FXRT Sport Glide	85->86	●	-
1340 FXRT Sport Glide	90->99	●	-
1340 FXST Softail	84->86	●	-
1340 FXSTC Softail Custom	85->86	●	-
1340 FXSTC Softail Custom	88->99	●	-
1340 FXSTS Springer Softail	90->99	●	-
1340 FXWG	87->88	●	-
1340 FXWG Wide Glide	85->86	●	-
1450 FLSTS/I Heritage Springer	00->03	●	-
1450 FLSTSC/I Springer Softail Classic	07->	●	-

1450 FLSTSC/I Springer Softail Classic	05->06	●	-
1450 FXSTS/I Springer Softail	07->	●	-
1450 FXSTS/I Springer Softail	00->04	●	-
1450 FXSTS/I Springer Softail	05->06	●	-



**07HD0910** 104.0 x 62.2 x 11.5

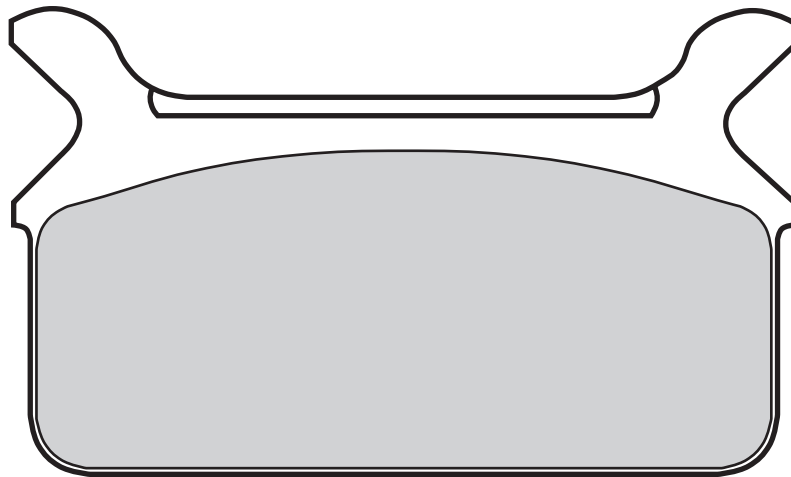

**3**



**HARLEY DAVIDSON**

FLT Series	88->99	-	●
FLT/H Series	86->87	-	●
1340 FLHS Electra Glide Sport	90	-	●
1340 FLHTC Electra Glide Classic	90->99	-	●
1340 FLHTC Ultra Classic	90->99	-	●
1340 FLST Heritage Softail	88->99	-	●
1340 FLTC Tour Glide Classic	90	-	●



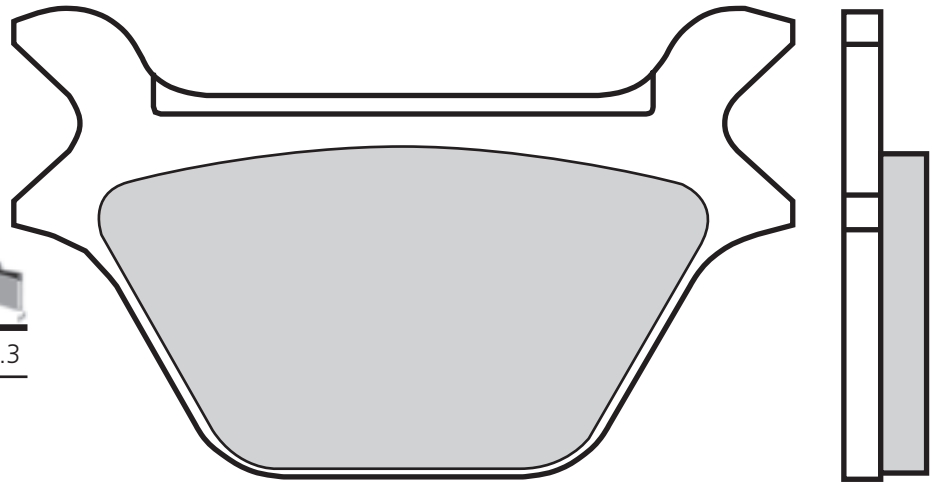

**07HD1011** 104.0 x 62.2 x 11.3



### HARLEY DAVIDSON

XLH Series	88->99	-	•
883 XLH Sportster	87->89	-	•
883 XLH Sportster	90->99	-	•
1100 XLH	87->88	-	•
1200 XLH Sportster	90->99	-	•
1340 FLHT Electra Glide Classic	87->99	-	•
1340 FLHTC Electra Glide Classic	93	-	•
1340 FLSTC Heritage Softail Cl.	90->99	-	•

1340 FLSTF Fat Boy	90->99	-	•
1340 FLSTN Heritage Softail Nost.	93->99	-	•
1340 FXDB Dyna Glide Daytona	91->99	-	•
1340 FXDB Dyna Glide Sturgis	91->99	-	•
1340 FXDB Sturgis	91->99	-	•
1340 FXDL Dyna Low Rider	93->99	-	•
1340 FXDWG Dyna Wide Glide	93->99	-	•
1340 FXE	82	-	•
1340 FXLR Low Rider Custom	87->88	-	•
1340 FXLR Low Rider Custom	93->99	-	•

1340 FXR	87->88	-	•
1340 FXR Super Glide	90->99	-	•
1340 FXRS Low Rider, Convert.	90->99	-	•
1340 FXRS Low Rider Sport	87->99	-	•
1340 FXRS Low Rider Sport Ed.	90->99	-	•
1340 FXRT Sport Glide	90->99	-	•
1340 FXSTC Softail Custom	88->99	-	•
1340 FXSTS Springer Softail	90->99	-	•
1340 FXWG	87->88	-	•

3



**07HD1109** 111.9 x 56.2 x 10.9

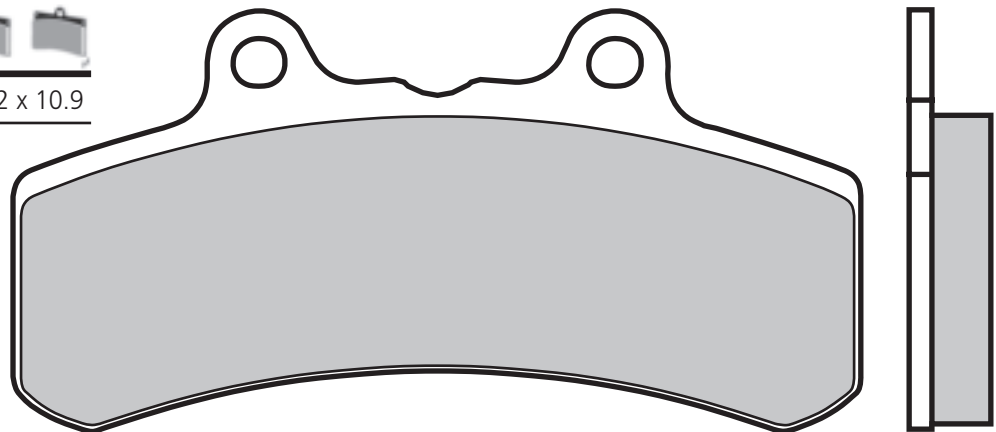

### BUELL

1200 M2	->97	•	-
1200 RS	93->	•	-





**07HD1210** 93.1 X 65.1 X 7.6

**07HD12SA** 93.1 X 65.1 X 7.6  
Sintered

**07HD12SP** 93.1 X 65.1 X 7.6  
Sintered

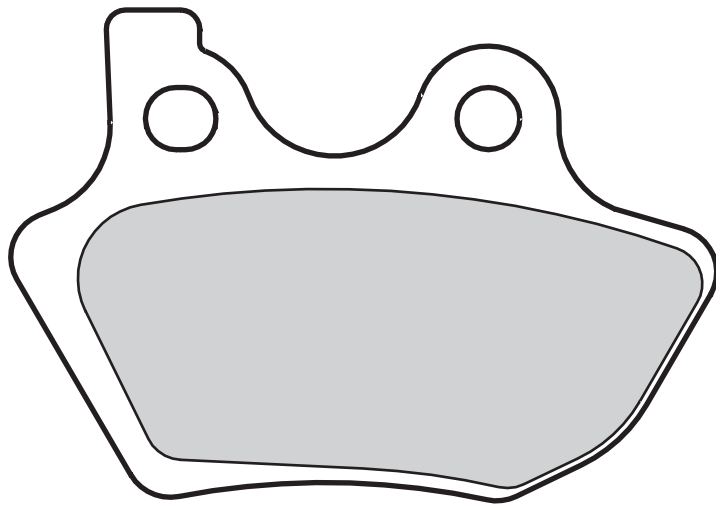
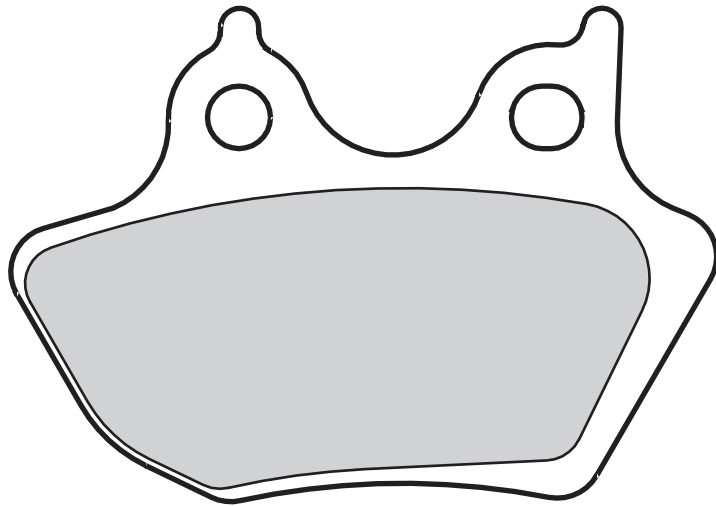

3

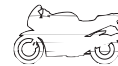
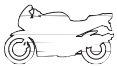

## HARLEY DAVIDSON

883	XL R Sportster	00->03	•	•
883	XL Sportster Custom	00->03	•	•
883	XLH Sportster	00->03	•	•
883	XLH Sportster Hugger	00->03	•	•
1130	VRSCA V-Rod	02->	•	•
1130	VRSCB V-Rod	04->	•	•
1200	XL Sportster Custom	00->03	•	•
1200	XL Sportster Sport	00->03	•	•
1200	XLH Sportster	00->03	•	•
1450	FLHR/I Road King	00->04	•	•
1450	FLHRCI Road King Classic	00->04	•	•
1450	FLHRS/I Road King Custom	04	•	•
1450	FLHT/I Electra Glide Standard	00->04	•	•
1450	FLHTC/I Electra Glide Classic	00->04	•	•

1450	FLHTCUI Ultra Classic Electra Glide	00->04	•	•
1450	FLSTC/I Heritage Softail Classic	00->04	•	•
1450	FLSTF/I Fat Boy	00->04	•	•
1450	FLSTS/I Heritage Springer	00->03	-	•
1450	FLTR/I Road Glide Classic	00->04	•	•
1450	FXD Dyna Super Glide	00->03	•	•
1450	FXDI Dyna Super Glide	04	•	•
1450	FXDL Dyna Low Rider	00->03	•	•
1450	FXDLI Dyna Low Rider	04	•	•
1450	FXDS Dyna Convertible	00->02	•	•
1450	FXDWG Dyna Wide Glide	00->03	•	•
1450	FXDWGI Dyna Wide Glide	04	•	•
1450	FXDX Dyna Super Glide Sport	00->03	•	•
1450	FXDXI Dyna Super Glide Sport	04	•	•

1450	FXDXT Dyna Super Glide T-Sport	00->03	•	•
1450	FXST/I Softail Standard	00->04	•	•
1450	FXSTB/I Night Train	00->04	•	•
1450	FXSTD/I Softail Deuce	00->04	•	•
1450	FXSTS/I Springer Softail	00->04	-	•





**07HD13SA** 101.6 X 38.6 X 8.9  
Sintered

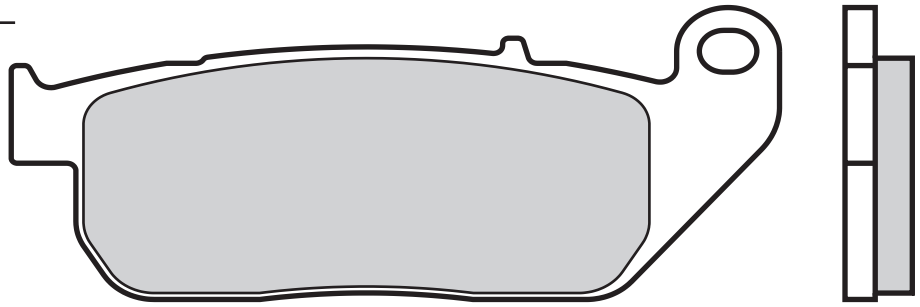

### HARLEY DAVIDSON

883	XL C Sportster Custom	04->	●	-
883	XL L Sportster Low	06->	●	-
883	XL Sportster	04->	●	-
1200	XL C Sportster Custom	04->	●	-
1200	XL N Nightster	07->	●	-
1200	XL R Sportster Roadster	04->	●	-

3



**07HD14SP** 85.7 X 44.3 X 10.0  
Sintered

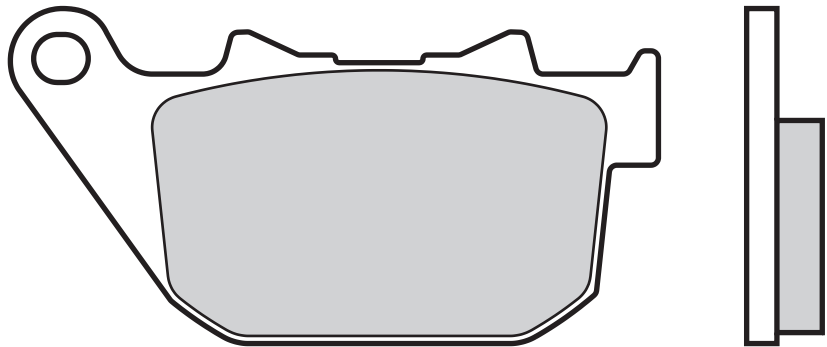

### HARLEY DAVIDSON

883	XL C Sportster Custom	04->	-	●
883	XL L Sportster Low	06->	-	●
883	XL Sportster	04->	-	●
1200	XL C Sportster Custom	04->	-	●
1200	XL N Nightster	07->	-	●
1200	XL R Sportster Roadster	04->	-	●





**07HD16SA** 97.3 X 63.4 X 8.0  
Sintered

**07HD16SP** 97.3 X 63.4 X 8.0  
Sintered

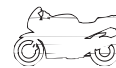
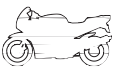
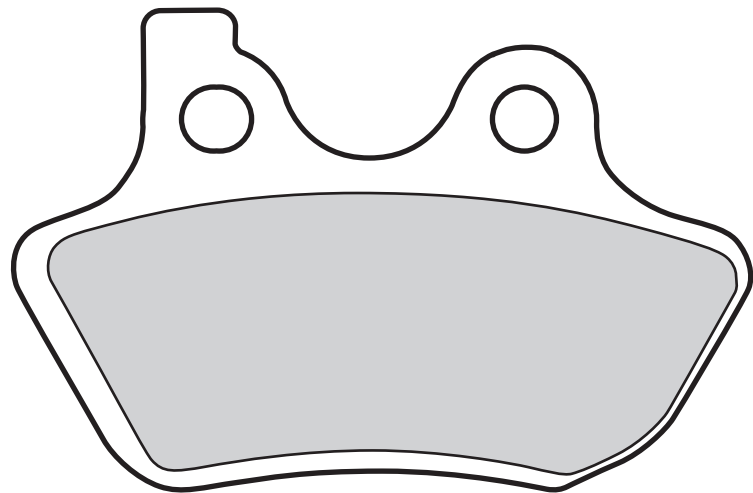
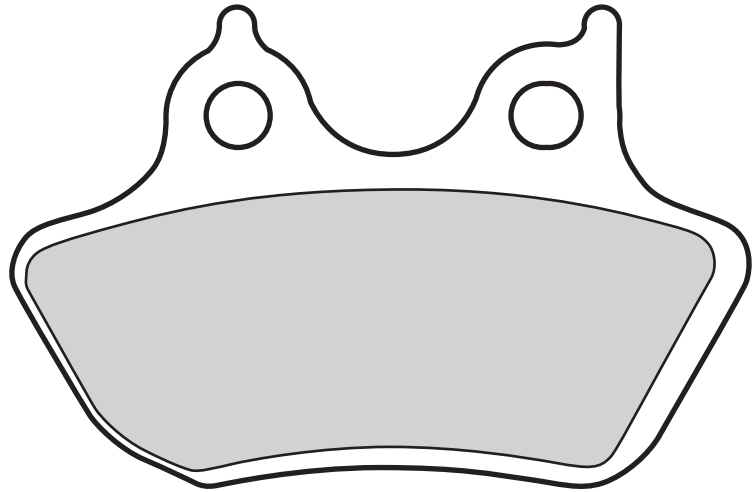

## HARLEY DAVIDSON

1450	FLHR/I Road King	05->	•	•
1450	FLHRCI Road King Classic	05->	•	•
1450	FLHRS/I Road King Custom	05->	•	•
1450	FLHT/I Electra Glide Standard	05->	•	•
1450	FLHTC/I Electra Glide Classic	05->	•	•
1450	FLHTCUI Ultra Classic Electra Glide	05->	•	•
1450	FLHXI Street Glide	06->	•	•

1450	FLSTC/I Heritage Softail Classic	05->06	•	•
1450	FLSTC/I Heritage Softail Classic	07->	•	-
1450	FLSTF/I Fat Boy	05->	•	•
1450	FLSTI Heritage Softail	06->	•	•
1450	FLSTN/I Softail Deluxe	05->	•	•
1450	FLTR/I Road Glide Classic	05->	•	•
1450	FLSTSC/I Springer Softail Classic	05->06	-	•
1450	FXDBI Dyna Street Bob	06->	•	•
1450	FXDC/I Dyna Super Glide Custom	05->	•	•

1450	FXDI 35th Anniversary Super Glide	06->	•	•
1450	FXDI Dyna Super Glide	05	•	•
1450	FXDLI Dyna Low Rider	05->	•	•
1450	FXDWGI Dyna Wide Glide	05->	•	•
1450	FXDXI Dyna Super Glide Sport	05->	•	•
1450	FXST/I Softail Standard	05	•	•
1450	FXST/I Softail Standard	06->	•	-
1450	FXSTB/I Night Train	05	•	•
1450	FXSTB/I Night Train	06->	•	-
1450	FXSTD/I Softail Deuce	05->	•	•
1450	FXSTS/I Springer Softail	05->06	-	•







**07HD18SP** 97.5 X 63.6 X 8.0  
Sintered

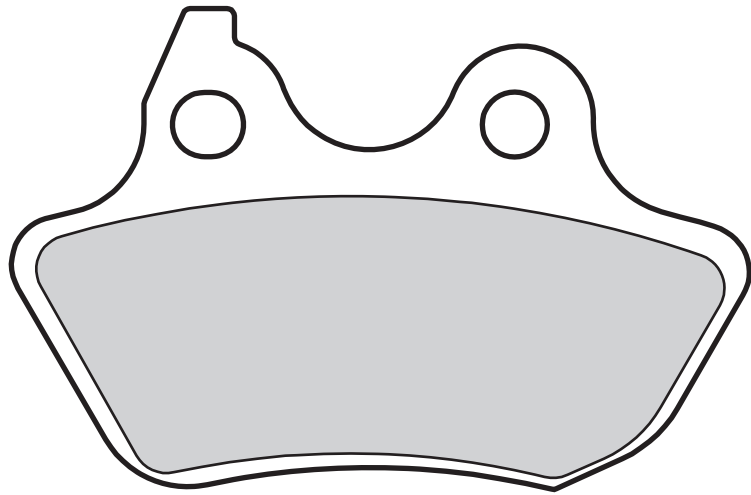
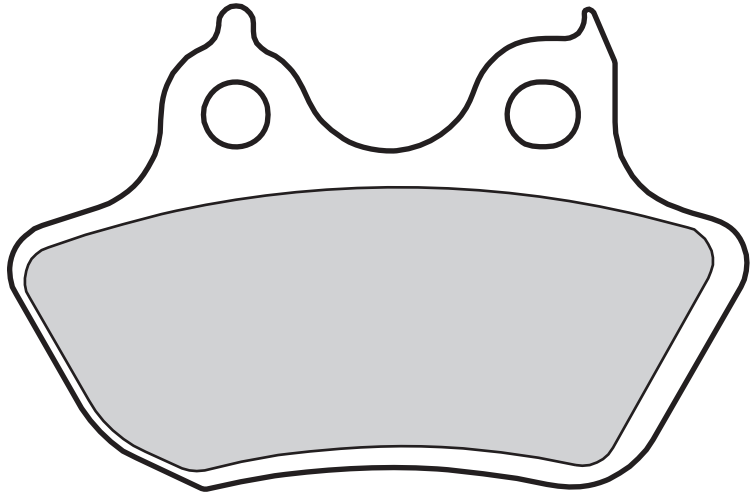

3

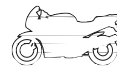
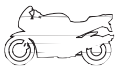

**HARLEY DAVIDSON**

1450	FLSTC/I Heritage Softail Classic	07->	-	•
1450	FLSTSC/I Springer Softail Classic	07->	-	•
1450	FXST/I Softail Standard	06->	-	•
1450	FXSTB/I Night Train	06->	-	•
1450	FXSTS/I Springer Softail	07->	-	•

