

Installation instructions:



502201

AKRAPOVIC RACING & EVOLUTION EXHAUST SYSTEM for the YAMAHA YZF-R1

Congratulations on purchasing an Akrapovic exhaust system. Please read these installation instructions carefully. If you have any trouble installing the system please contact your authorized dealer!

IMPORTANT INFORMATION

Exclusion of Certain Liability

1. The manufacturer, importer or dealer shall not be liable for any incidental damage including personal injury or any other damages caused by improper installation or operation of the Akrapovic exhaust system. When installing the Akrapovic exhaust system be careful that the exhaust system does not touch other parts sensitive to high temperature.
2. Akrapovic makes no representation or warranties with regard to damage caused by the improper installation, use and maintenance of the Akrapovic exhaust system. The warranty is limited to defects recognized by our technical department and to normal use, and excludes items subject to normal wear (gaskets and damping wool). The guarantee is void in case of accident, modification, improper or competition use.
3. Do not attempt to install the Akrapovic exhaust system on a motorcycle for which it was not made or tested by Akrapovic.
4. When the exhaust system gets very hot during operation, be careful not to burn yourself on the exhaust system or parts which are in direct contact with it, even when the motor is not running. Also protect other people, especially children, from the injuries mentioned above.
5. In some cases Akrapovic exhaust system kits contain chemical products (ceramic anti-seizing grease; bolt sealant). Handle with care, do not inhale or swallow. Avoid excessive contact with skin, eyes or mucous membranes. Keep out of reach of children.
6. Technical specifications of Akrapovic exhaust systems and related products subject to change without notice.

Trademarks

The Akrapovic Exhaust System Technology logo is a registered trademark of Akrapovic d.d.

Akrapovic website

Information about Akrapovic exhaust systems and related products is available on the Akrapovic website at:

<http://www.akrapovic.com/>

Copyright

No part of the Akrapovic exhaust system or its documentation may be reproduced or distributed in any form or by any means without the prior written authorization of the Akrapovic company.

© Akrapovic, d.d. All rights reserved.

Symbols

The following symbols are used throughout these installation instructions:



USE BOLT SEALANT; Apply 3 to 4 small drops of bolt sealant onto the cleaned and degreased threads before tightening bolts. **WARNING! Avoid contact with skin, eyes and mucous membranes. Do not inhale fumes. Keep out of the reach of children.**



USE ANTI-SEIZING GREASE (white tube); Prevents seizing, corrosion and excessive wear between the titanium components of your exhaust system. **WARNING! Avoid eye contact. Avoid excessive skin contact. Keep out of the reach of children.**



USE ANTI-SEIZE LEAD-FREE COPPER PASTE (black tube); Provides trouble-free and long-lasting protection against seizing, corrosion and rusting of bolts, threaded ends, nuts, joints, etc. Also protects against vibration, wear and impact. **WARNING! Avoid eye contact. Avoid excessive skin contact. Keep out of the reach of children.**

INSTALLATION INSTRUCTIONS

 **BEFORE INSTALLING CHECK SCHEMATIC OF THE EXHAUST SYSTEM!**

! IF ANY ITEMS IN THE AKRAPOVIC EXHAUST SYSTEM PACKAGE ARE MISSING PLEASE CONTACT YOUR AUTHORIZED DEALER. KEEP THE SCHEMATIC FOR FUTURE REFERENCE.

! THESE INSTALLATION INSTRUCTIONS MUST BE READ CAREFULLY IN ORDER TO ENSURE PROPER INSTALLATION AND OPERATION OF THE AKRAPOVIC EXHAUST SYSTEM.

! THE EXHAUST SYSTEM CAN BE EXTREMELY HOT. ALLOW THE MOTORCYCLE TO COOL DOWN BEFORE BEGINNING INSTALLATION.

 **WE ADVISE YOU TO LEAVE INSTALLATION TO A QUALIFIED SERVICEMAN. IMPROPER INSTALLATION MAY RESULT IN A SHORTER LIFETIME OF THE EXHAUST SYSTEM AND/OR DAMAGE TO THE MOTORCYCLE.**



T-handle 8mm wrench
T-handle 10mm wrench
T-handle 12mm wrench
T-handle 13mm wrench
T-handle 12mm swiveling wrench
T-handle 4mm three hexagon key wrench
T-handle 5mm three hexagon key wrench
T-handle 6mm three hexagon key wrench
Combination 10mm wrench
Combination 12mm wrench
Combination 14mm wrench
Spring puller
Small cross head screwdriver

REMOVAL OF ORIGINAL EXHAUST SYSTEM:

1. Put the motorcycle on a side stand, we recommend a racing stand. Make sure, that surface is solid and flat.
2. Unlock and remove the passenger's seat (**Figure 1**). Unscrew and remove the driver's seat (**Figure 2**). Unscrew the bolts and remove the original mufflers heat shields (**Figure 3**).



Figure 1



Figure 2



Figure 3

3. Unscrew the bolt and undo the plastic fasteners from the seat cowling (Figure 4, 5, 6, 7, 8). Unhook the cable for locking/unlocking the seat and remove the seat cowling (Figure 9).



Figure 4



Figure 5



Figure 6



Figure 7



Figure 8



Figure 9

4. Unscrew and remove the original link pipe heat shield and unhook the brake line (Figure 10, 11).



Figure 10



Figure 11

5. Unscrew the bolt from the link pipe metal clamp (Figure 12), the bolt from the muffler hanging bracket and remove the muffler. Perform the process on both sides of the motorcycle (Figure 13, 14).



Figure 12



Figure 13



Figure 14

6. Disconnect the stop switch electrical lead (Figure 15). Unscrew the bolts from the rider's footrest bracket. **WARNING: do not disconnect the brake fluid tube! (Figure 16, 17).** Unscrew and remove the lambda sensor (Figure 18). **WARNING: make sure not to damage lambda sensor's electrical lead!** Unscrew and remove the metal clamp of the original link pipe/header assembly joint (Figure 19), unscrew the bolt from the original link pipe metal bracket and remove the original link pipe (Figure 20, 21).



Figure 15



Figure 16



Figure 17

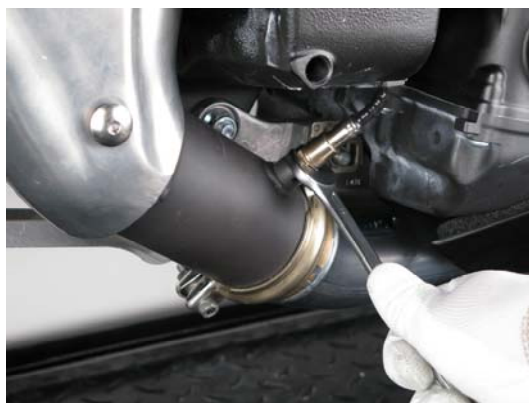

Figure 18



Figure 19



Figure 20



Figure 21

7. Unscrew and remove the lower part of the cowling (Figure 22, 23).



Figure 22



Figure 23

8. Unscrew the bolts and remove the plastic fasteners from the left and right side of the cowling. Partially remove the cowling, disconnect the turn signal electrical connector and then completely remove the cowling (Figure 24, 25, 26, 27, 28). Perform the process on both sides of the motorcycle. **WARNING: be careful not to damage the electrical leads or connectors of the turn signals during process of cowling removal!**



Figure 24



Figure 25



Figure 26



Figure 27



Figure 28

9. Unscrew the bolt from chassis hanging bracket of the collector header assembly (Figure 29). Unscrew the bolt from the water cooler hanging bracket and slightly remove cooler. **WARNING: do not disconnect the cooling system tubes!** Make sure not to damage the cooling fins (Figure 30). Unscrew the nuts from the header tube flanges and remove the original header tubes; make sure not to damage the cooling fins (Figure 31, 32).



Figure 29

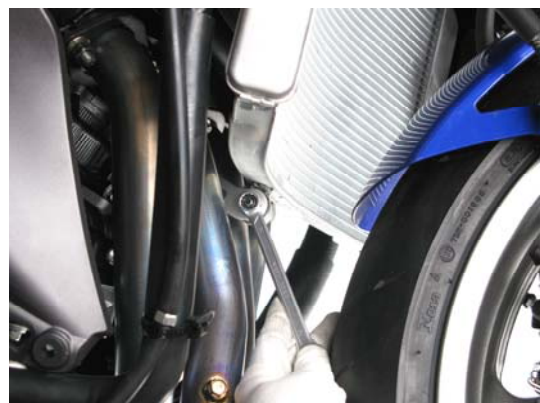

Figure 30



Figure 31



Figure 32

INSTALLATION OF THE AKRAPOVIC RACING OR EVOLUTION EXHAUST SYSTEM:

1. Set up the sleeves together with the flanges and springs; make sure they are correctly oriented and that the holes for attaching the springs line up with the loops on the header tubes; hand tighten the flanges; make sure not to damage the cooling fins (Figure 33, 34).



Figure 33



Figure 34

2. Insert the header tubes properly and attach the springs; make sure not to damage the cooling fins (Figure 35, 36).
WARNING: make sure, that springs pull the headers all the way into the sleeves – use rubber mallet if necessary to tap the connections into place!



Figure 35



Figure 36

- Slide the collectors onto the header tubes and attach the springs (**Figure 37, 38**). For Evolution exhaust only: coat the interior side of the input bushes of the titanium collectors with Akrapovic ceramic anti-seizing grease (white tube). **WARNING: make sure, that springs pull the collectors all the way to the headers – use rubber mallet if necessary to tap the connections into place!**

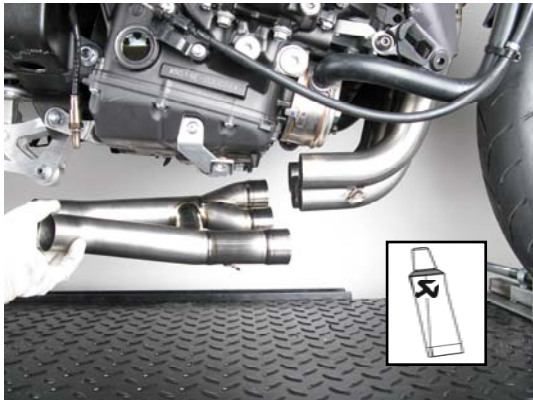

Figure 37



Figure 38

- Reposition the original link pipe bracket to the Akrapovic link pipe using original bolt and washer; tighten the bolt to a specified torque (**Figure 39, 40**). Reposition the original aluminium heat shield to the Akrapovic link pipe using original spacers and Akrapovic 12mm bolts; tighten the bolts to a specified torque (**Figure 41, 42, 43**). Slightly bent the aluminium original heat shield if it touches the link pipe (**Figure 44**).



Figure 39



Figure 40



Figure 41



Figure 42



Figure 43



Figure 44

- Redirect the lambda electrical lead (as shown in figure) to enable correct installation of the sensor into Akrapovic link pipe. **WARNING: make sure that electrical lead of the lambda sensor does not touch hot or moving parts of the motorcycle! (Figure 45).** Tighten the lambda sensor; make sure not to damage the electrical lead during this process. **WARNING: grease only the threads of the lambda sensor with Akrapovic anti-seize lead-free copper paste (black tube)! (Figure 46).**



Figure 45



Figure 46

- Slide the link pipe onto the collectors and attach the springs. **For Evolution exhaust only:** coat the interior side of the input bushes of the titanium link pipe with Akrapovic ceramic anti-seizing grease (white tube). **WARNING: make sure, that springs pull the link pipe all the way onto the collectors – use rubber mallet if necessary to tap the connections into place! (Figure 47, 48).**

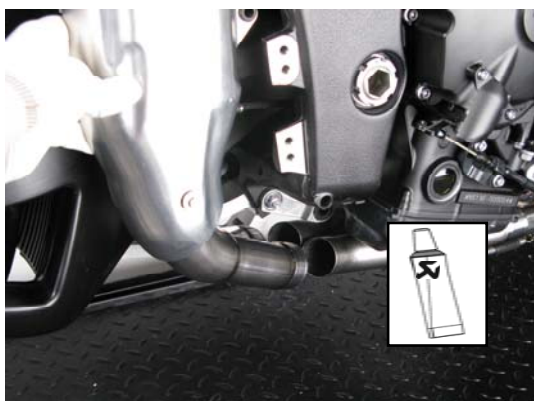

Figure 47



Figure 48

7. Hand tighten the link pipe original bracket using stock bolt and replace the rider's footrest bracket, brake line and reconnect the rear brake stop switch in the reverse order from the order in which they were removed (Figure 49, 50, 51).



Figure 49

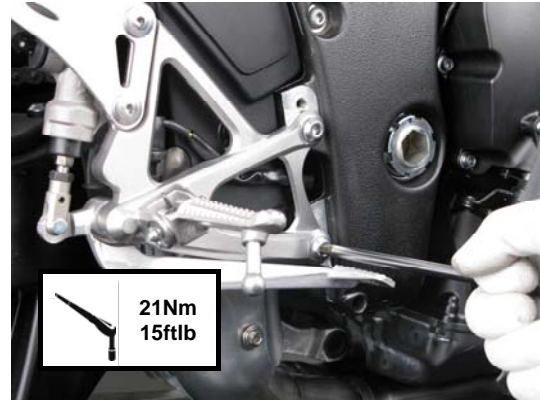

Figure 50



Figure 51

8. Tighten the flanges and tighten the bracket to the water cooler (Figure 52, 53). **WARNING: make sure not to damage the cooling fins of the water cooler or any other part of the motorcycle during this process!**

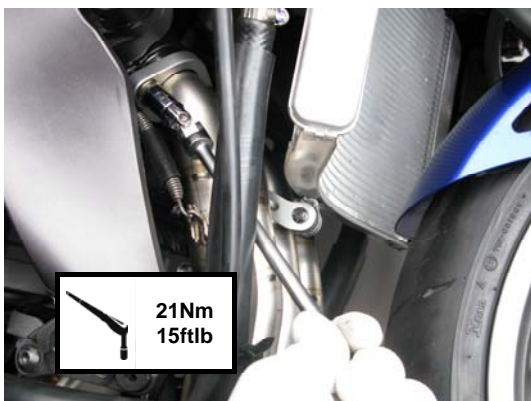

Figure 52

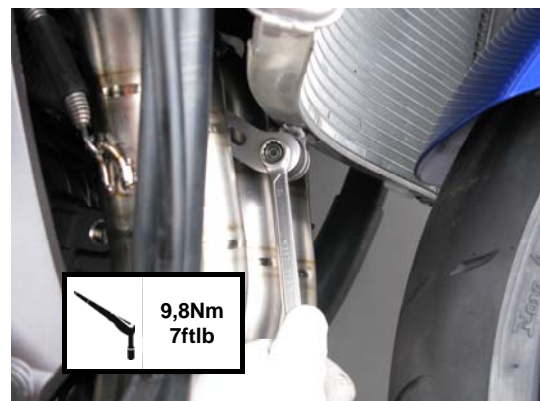

Figure 53

9. Reconnect the turn signal electrical connectors and replace all cowlings in the reverse order from the order in which they were removed (Figure 54, 55). **WARNING: make sure, that you reconnect all electrical leads which were disconnected during installation!**



Figure 54



Figure 55

10. Correctly position the carbon-fiber clamps and slide them onto the mufflers as seen in the figures. **WARNING: open the clamp slightly wider than the diameter of the outer sleeve of the muffler – do not scrape it along the muffler outer sleeve! (Figure 56, 57).**



Figure 56



Figure 57

11. Correctly position and install the Akrapovic carbon-fiber heat shields onto the link pipes; make sure the heat / distance washers are correctly installed (Figure 58, 59, 60).



Figure 58



Figure 59



Figure 60

12. Remove the original metal collar and insert the additional Akrapovic aluminium muffler bracket to the chassis hanging bracket – use the bolt and washer supplied in the Akrapovic kit. Do not fully tighten. Make sure the additional parts from the Akrapovic kit are correctly installed (Figure 61, 62, 63). Perform the process on both sides of the motorcycle.



Figure 61



Figure 62



Figure 63

13. Position the mufflers correctly and slide them onto the outlet side of the link pipes (**Figure 64**). **For Evolution exhaust only:** coat the interior side of the input of the mufflers with Akrapovic ceramic anti-seizing grease (white tube). Position and attach the springs (**Figure 65**). Hand tighten the muffler clamps to Akrapovic aluminium muffler bracket using Akrapovic bolts and washers (fi 15mm). Align the mufflers in respect to the motorcycle and tighten the bolts of the Akrapovic muffler clamps, muffler brackets and the link pipe stock bracket (**Figure 66, 67, 68, 69**). Make sure the link pipe or mufflers are not touching the frame and other parts of the motorcycle.



Figure 64



Figure 65



Figure 66



Figure 67

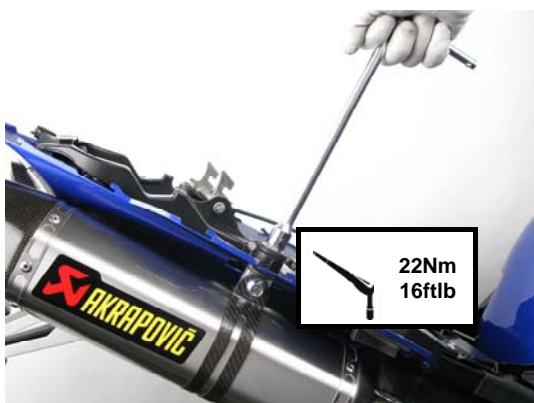

Figure 68



Figure 69

14. Assemble the seat cowl and seats in the reverse order from the order in which they were removed. (Figure 70, 71, 72, 73).

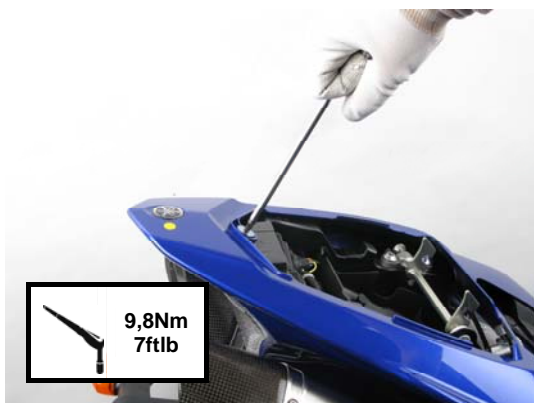

Figure 70



Figure 71



Figure 72



Figure 73

Final installation:

1. Clean grease spots:
 - a. Mufflers – carbon-fiber outer sleeve: use a soft dry cloth.
 - b. Mufflers – titanium outer sleeve: use a soft cloth sprayed with a multi-purpose spray lubricant (WD-40 or equivalent).
 - c. Mufflers – carbon-fiber outlet cap: use a soft dry cloth.
 - d. RACING - stainless steel link pipe, collectors and header tubes: use a soft cloth sprayed with a contact cleaner, then wipe with a soft dry cloth. **WARNING:** inlet caps and welded link pipes in RACING option are made out of titanium – check section “e” (cleaning procedure for evolution exhaust)!
 - e. EVOLUTION - inlet cap and welded link pipes, titanium link pipe, collectors and header tubes : use a soft cloth sprayed with a multi-purpose spray lubricant (WD-40 or equivalent).

Cleaning will prevent spots from burning onto the surface. Do not use aggressive chemical cleaners, because they can damage the sticker.

WARNING:

Please note that certain aftermarket exhaust systems may not comply with applicable California laws and regulations, and may therefore be prohibited for use on California highways or roads, or on roads or vehicles otherwise subject to emissions control requirements.

Akrapovič exhaust systems for automobiles and motorcycles mounted downstream of the catalytic converter (also known as “cat-back systems”) are considered “replacement parts” in California by the California Air Resources Board (CARB), and do not require an exemption or executive order from CARB to be sold in California. However, California prohibits the use of any aftermarket exhaust system that modifies, removes or replaces original equipment catalysts, unless CARB has issued an Executive Order as to such part or system.

Further, Akrapovič parts or exhaust systems used or intended for use on “racing vehicles” (i.e. a competition vehicle used exclusively for competition on closed-course circuits) do not require an exemption or Executive Order from CARB to be sold in California. However, such parts are prohibited from use on California public highways or roads, even if occasionally used “off-road.”

Position of the correctly installed Akrapovic **RACING OR EVOLUTION** system (Figure 74).



Figure 74

2. Check the operation of the brakes and suspension. Make sure all the bolts are sufficiently tightened. In case the exhaust system touches the cowling or other parts repeat the adjustment of the exhaust system or contact your authorized dealer.

! IT IS NORMAL IF WHITE SMOKE COMES OUT OF THE MUFFLER ON FIRST OPERATION.

! DO NOT STAND BEHIND THE MUFFLER ON FIRST OPERATION.

! DO NOT USE AUTOMOTIVE WHEEL CLEANERS OR ANY CLEANING PRODUCTS WHICH CONTAIN ACIDIC ADDITIVES TO CLEAN AKRAPOVIĆ EXHAUST SYSTEMS.

MAINTENANCE OF THE AKRAPOVIĆ EXHAUST SYSTEM:

1. Clean the titanium exhaust components with a multi-purpose spray lubricant (WD-40 or equivalent), carbon fiber exhaust components with soft and dry cloth and stainless steel components with soft cloth sprayed with contact cleaner, then wipe with soft and dry cloth. Do not use aggressive chemical cleaners, because they can damage the sticker. A change in the color of the exhaust system is normal due to the high temperatures.
2. The wearing out of the muffler silencing material depends on the type of the engine and riding style. Contact your dealer/serviceman if visible changes appear on muffler's outer sleeve or the noise level is increased.
3. Periodically make sure all the bolts and springs are sufficiently tight.