



EVOTECH
THE RIGHT CHOICE

versione

9.1

EVOTECH

EVOTECH repräsentiert ein junges und dynamisches Unternehmen, das Technology, Innovation und Qualität verbindet. Dank der Synergien zwischen hoch qualifiziertem Personal und der Anwendung bester Technologien übernimmt Evotech eine Führungsposition auf dem Markt. Evotech konzipiert und realisiert Produkte auf absolutem Top Niveau. Die Kombination all dieser Fähigkeiten, also die 'TECH' nische 'EVO'lution spiegeln sich in unserem Firmennamen wider. Der Grundgedanke von Evotech ist es, alle Produktionsschritte innerhalb des Unternehmens zu haben, um somit der steigenden Nachfrage eines dynamischen Marktes in kurzer Zeit gerecht zu werden. Evotech legt besonderes Augenmerk auf die Entwicklung fortschrittlicher Produkte für die vielfältigen Anforderungen des Marktes: Systemsicherheit, Funktionalität, Einfachheit in der Montage, einzigartiger Stil, Qualität in allen Prozessen und Langlebigkeit. Schließlich übernimmt die Evotech-Forschung eine wichtige Rolle im Unternehmen, um dem Kunden immer die beste und brauchbarste Lösung zu bieten.

EVOTECH brand represents a young and dynamic company that works mixing technology, innovation and quality. Thanks to the synergy among a skilled staff and thanks also to the best technologies on the market, Evotech designs, realizes and offers you high quality products. The ability to combine all these elements can be simply translated in our brand core, TECHNOLOGICAL EVOLUTION. Evotech aims to have all the production steps inside the company in order to maximize and to face the market demand in short time. By paying a particular attention to products progress Evotech maintains the right approach with the market requirements: system functionality, simplicity in the assembling, an unique style, quality in all the processes. Finally Evotech research has an important role in the company in order to always offer the market the most rich and useful solutions.

AGENT

fax tel

EVOTECH fax +39 0461-782707 tel +39 0461-780184

www.evotech-rc.it / e-mail: info@evotech-rc.it

.....

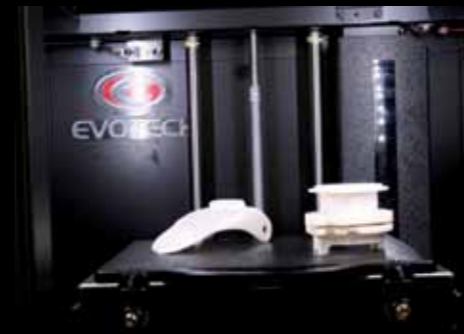
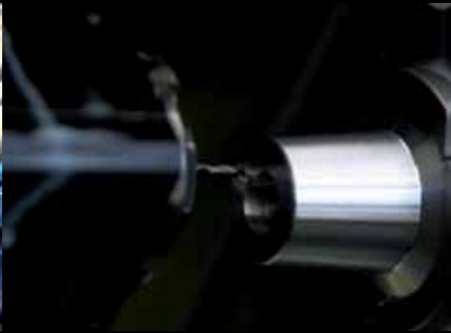
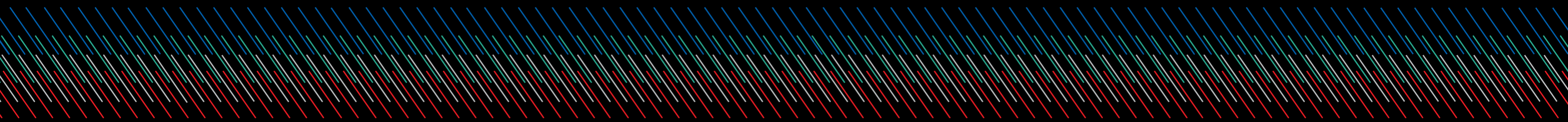

Biagio Calvaruso, Kaufmännische Leitung
Marco Ongaro, Werkstatt
Ing. Matteo Tisi, Entwicklung
Maurizio Osler, Technik
Maria Battaglia, Verwaltung
Gloria Zanghellini, Export

INDEX

NUMMERNSCHILDHALTER \ <i>TAIL TIDY</i>	01 - 05
STURZPADS \ <i>FRAME SLIDERS</i>	06 - 13
ALUMINIUM ÖSENSCHRAUBEN \ <i>ALUMINIUM PLUGS</i>	14
MOTORSCHÜTZER \ <i>ENGINE PROTECTOR</i>	15
GEMS OF THE WIND	16
FINAL STORM	17 - 18
PADDOCK STANDS	19
ACHSBLÖCKE \ <i>AXIAL BLOCKS</i>	20
THUNDERBOLTS	21 - 24
ACHSABDECKUNGEN FÜR T-MAX \ <i>WHEEL PIN COVER T-MAX</i>	25
ÖL-EINFÜLLSCHRAUBE \ <i>OIL FILLER CAP</i>	26
BREMSFLÜSSIGKEITSBEHÄLTER \ <i>FLUID RESERVOIRS</i>	27-28
TANKDECKEL \ <i>FUEL CAP</i>	29
SCHNELLWECHSEL-TANKDECKEL \ <i>RAPID FUEL CAP</i>	30 - 32
SCHRAUBENSÄTZE FÜR TANKDECKEL \ <i>FUEL CAP BOLTS KIT</i>	33 - 34
SCHRAUBENSÄTZE FÜR VERKLEIDUNGSSCHEIBEN \ <i>SCREEN BOLTS KIT</i>	35 - 36
SCHRAUBENSÄTZE \ <i>ERGAL BOLTS</i>	37 - 41
FELGENRAND-AUFKLEBER \ <i>WHEEL STICKERS</i>	42
RACING ZUBEHÖR \ <i>RACING ACCESSORIES</i>	43 - 44
ALLGEMEINE GESCHÄFTSBEDINGUNGEN \ <i>GENERAL SALE CONDITIONS</i>	47 - 48

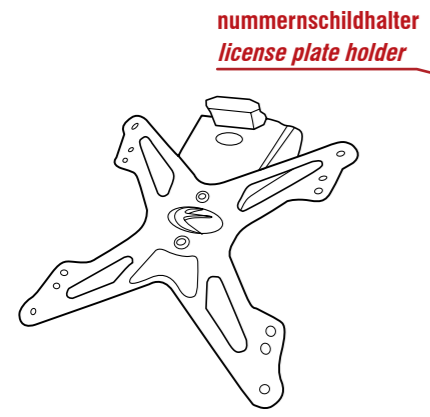
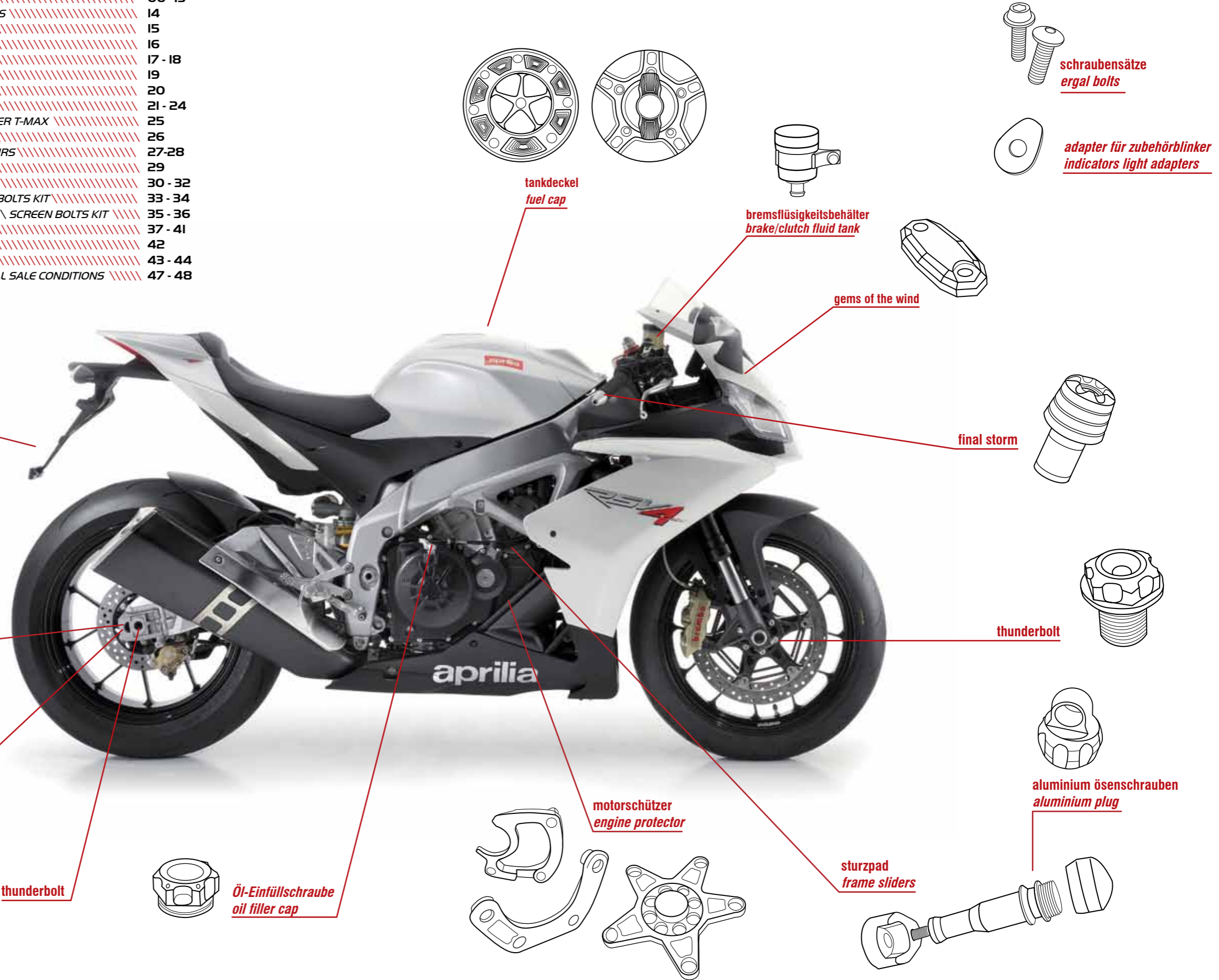

nummernschildhalter
license plate holder

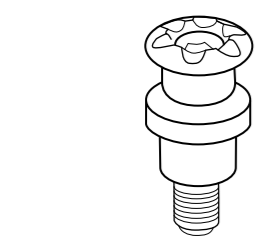

paddock stands

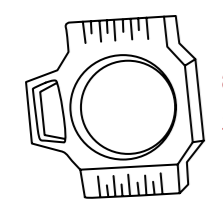

achsblöcke
axial blocks

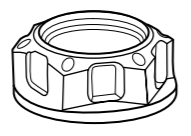

thunderbolt

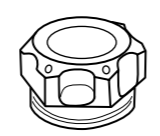

Öl-Einfüllschraube
oil filler cap

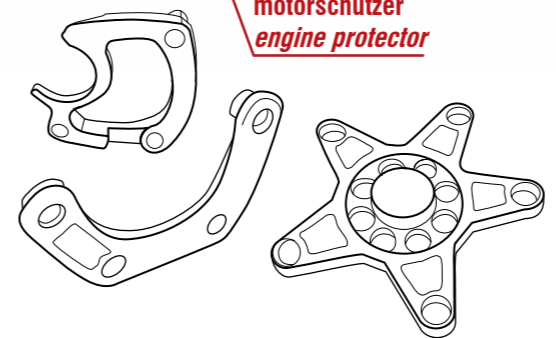

motorschützer
engine protector

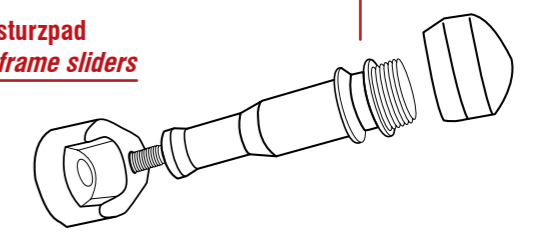

sturzpad
frame sliders

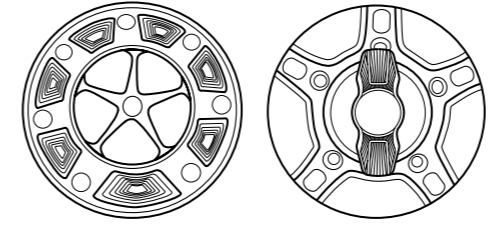

tankdeckel
fuel cap

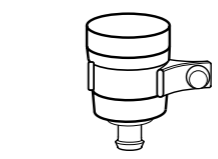

bremsflüssigkeitsbehälter
brake/clutch fluid tank



gems of the wind

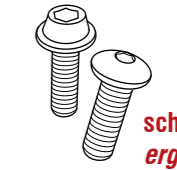

schraubensätze
ergal bolts



adapter für zubehörblinker
indicators light adapters

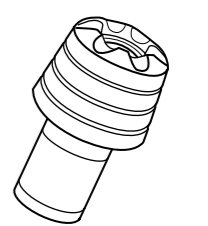

final storm

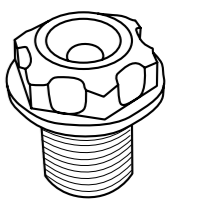

thunderbolt

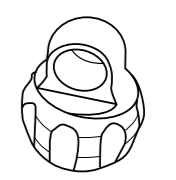

aluminium ösenschrauben
aluminium plug

KENNZEICHENHALTER TAIL TIDY

Die EVOTECH Kennzeichenhalter sind für Racingzwecke verstellbar, extrem leicht, langlebig und mit einem revolutionären Design. Hierbei ist die Kennzeichenplatte und sämtliche weiteren Aluminiumteile schwarz eloxiert. Die Kennzeichenplatten sind auf die Kennzeichengrößen der jeweiligen Länder angepasst. Solide Unterstützung aus dem speziellen TECNOPOLYMER Material mit ANTI-TUNING SYSTEM zur Verringerung der andauernden Vibrationen im Fahrbetrieb. EVOTECH Kennzeichenhalter verfügen über eine Aufnahme der ECE-geprüften LED-Kennzeichenleuchte. Jeder Kit verfügt über spezielle Halterungen aus Aluminium je nach Modell.

- Optional:
- LED-Kennzeichenbeleuchtung
 - Reflektorhalter
 - Blinkerhalter
- Patentiertes Produkt, geschütztes Design

Evotech new racing adjustable, extremely light and with a revolutionary design license plate holder. Black anodized, varnished aluminium support adjusted to each country. Solid support made of tecnopolymer material with ANTI-TUNING SYSTEM to reduce the continous irritating road vibrations. Our kits include the supports for the fixing of aftermarket indicators light with one single hole diameter 10mm. Each kit includes specific brackets made of aluminium diversified depending on the model.

- Optional:
- lighting device for the license plate
 - rear reflecting support
 - supports for original indicators light
- Patented product, Registered design

**5 JAHRE GARANTIE
5 YEARS WARRANTY**

Supporto

- \ **Schockproof Technopolymer**
schockproof tecnopolymer material
- \ **schwarzes UV-beständiges Basismaterial**
black UV-resistant colour
- \ **FEM-Analyse**
FEM analysis
- \ **auf dem Schwingungs-Prüfstand getestet Kennzeichenplatte**
tested product



Placca

- \ **in spezieller Aluminiumlegierung aus der Luftfahrt gefertigt**
machined from billet aluminium
- \ **schwarze Pulverbeschichtung**
black anodization
- \ **länderspezifische Plattengrößen**
specific size for each country
- \ **in zwei Positionen einstellbar**
two interchangeable positions



KENNZEICHENHALTER TAIL TIDY

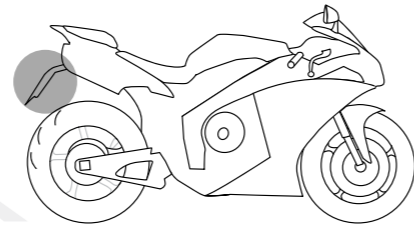

MARKE/BRAND	MODELL/MODEL	JAHR/YEAR	CODE	EURO w/o tax
APRILIA	Tuono / RSV1000	'04-'08	ESTR-1001	70,00
	Dorsoduro	'08-'10	ESTR-1002	70,00
	RS 125	'08-'10	ESTR-1004	70,00
	Shiver	'07-'10	ESTR-1003	70,00
	RSV4 FACTORY/R	/	ESTR-1005	70,00
BMW	S1000RR	'10	ESTR-1102	90,00
	K1300R/S	'10	ESTR-1101	110,00
DUCATI	999/749 #	'10	ESTR-0801	140,00
	1198/1098/848** ++	/	ESTR-0802	160,00
	HYPERMOTARD	'07-'10	ESTR-0804	70,00
	Monster 696*	/	ESTR-0805	105,00
	Monster 1100/796*	/	ESTR-0806	105,00
	Streetfighter	/	ESTR-0807	75,00
	Multiestrada+**	'10	ESTR-0808	120,00
Multiestrada+** (kompatibel mit Taschen/with travel bags)	'10	ESTR-0809	175,00	
HARLEY DAVIDSON	Sportster	/	ESTR-1201	95,00
HONDA	CBR 600 RR	'03-'06	ESTR-0103	100,00
	CBR 1000 RR	'04-'07	ESTR-0103	100,00
	CBR 1000 RR	'08-'09	ESTR-0111	149,00
	CBR 1000 RR**	'10	ESTR-0112	120,00
	CBR 600 RR ++ # s.d.	'07-'10	ESTR-0108	190,00
CB 1000 R**	'08-'10	ESTR-0110	140,00	
KAWASAKI	Z 750**	'07-'10	ESTR-0406	85,00
	Z 1000**	'07-'09	ESTR-0406	85,00
	Z 1000	'10	ESTR-0411	70,00
	ZX6R ++ #	'07-'08	ESTR-0405	130,00
	ZX6R**	'09-'10	ESTR-0407	70,00
	ZX 10 R**	'08-'10	ESTR-0407	70,00
	ER-6N	'09-'10	ESTR-0410	70,00
Versys	'10	ESTR-0412	75,00	
KTM	690 SMC / Enduro	/	ESTR-0902	120,00
	990 Supermoto / R / T	/	ESTR-0904	90,00
	690 Duke	'08-'10	ESTR-0901	70,00
	1190 RC8	'08-'10	ESTR-0903	70,00
690 Supermoto / R	'07-'10	ESTR-0901	70,00	
MV AGUSTA	Brutale	< '10	ESTR-0501	70,00
	F4	'10 >	ESTR-0502	77,00
SUZUKI	GSX-R 600 / 750*	'06-'07	ESTR-0306	70,00
	GSX-R 600 / 750*	'08-'10	ESTR-0309	70,00
	GSX-R 1000*	'05-'08	ESTR-0305	70,00
	GSX-R 1000	'09-'10	ESTR-0312	70,00
	SV-650/S	'03-'08	ESTR-0311	70,00
	Gladius#	'09 >	ESTR-0313	135,00
TRIUMPH	SPEED TRIPLE	'06-'07	ESTR-0701	70,00
	DAYTONA 675	'06-'10	ESTR-0702	70,00
	STREET TRIPLE +	'07-'10	ESTR-0703	110,00
	SPEED TRIPLE	'08-'10	ESTR-0704	149,00
YAMAHA	R6	'06-'10	ESTR-0208	70,00
	R1	'04-'08	ESTR-0204	70,00
	R1 (nur für originalauspuff/ only for original exhaust)	'09-'10	ESTR-0213	70,00
	R1 (für zubehörauspufft/for aftermarket exhaust)	'09-'10	ESTR-0214	70,00
	FZ6/Fazer	'04-'10	ESTR-0207	70,00
	FZ1/Fazer	'06-'10	ESTR-0209	70,00
	FZ8	'10	ESTR-0209	70,00
	T-MAX	'08-'10	ESTR-0210	125,00
	YZF-R 125	'08-'10	ESTR-0211	70,00
XJ6	'09-'10	ESTR-0212	70,00	

* Diese Kennzeichenhalter beinhaltet keine Blinkerhalter, da die Blinker im Heck montiert sind.

** Diese Kennzeichenhalter beinhalten gefräste Aluminiumteile aus der Luftfahrtindustrie

Der Inhaber markiert sind LED-Rücklicht

+ Diese Kennzeichenhalter beinhalten die LED Kennzeichenleuchte EL T001 von EVOTECH

++ Diese Kennzeichenhalter beinhalten die LED Kennzeichenleuchte EL T001 von EVOTECH und die Reflektorhalter s.d. Diese Kennzeichenhalter sind mit anderen Rabatten belegt.

* These license plate holders do not include indicators light kit because the bike includes them on the tail.

** These license plate holders include some pieces which are machined from aluminium billet

These license plate holders include the rear led light

+ These license plate holders include the led light ELT001

++ These license plate holders include the led light ELT001 and the reflecting support ELT003 s.d. These license plate holders have a different discount.

KENNZEICHENHALTER TAIL TIDY

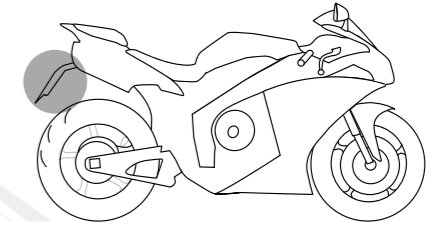

LED-KENNZEICHENBELEUCHTUNG / TURN SIGNALS LIGHTS

Indicator lights with high brightness LED light, homologated and using a black anodized mounting stem. The fixing stem includes a M10 nut. The indicator light has to be mounted with some resistances 6-10-21 W or with a LED flasher device

CODE	DESCRIPTION	EURO w/o tax
F-01	urn signal model 1	30,00
F-02	turn signal model 2	30,00
RES-6W	resistor 6W	22,00
RES-10W	resistor 10W	24,00
RES-21W	resistor 21W	26,00
FLASH-01	led flasher unit	15,00



LED-KENNZEICHENBELEUCHTUNG / LED LIGHT

Nummernschildbeleuchtung mit HIGH-Brightness LED-Technologie. Das kleine Gehäuse ist aus bewährten Aluminiumlegierungen aus der Luftfahrt gewonnen und elegant schwarz satiniert. Dieses Zubehör ist wie folgt aufgebaut: eine integrierte elektronische Schaltung für die Stabilisierung der Helligkeits-Intensität im Gebrauch. Die LEDs sind auf eine Laufleistung von 500.000 km getestet. Im ECE-Prüfungsverfahren.Registriertes Design ®

Lighting device obtained from an aluminium billet with high brightness LED technology. This accessory is equipped with an integrated electronic circuit for the stabilization of the brightness intensity while in use. The waterproof LED is resistant to the most extreme functioning conditions. Granted for 500.000km. Product waiting for homologation.Registered design



ELT-001 25,00

REFLEKTORHALTER / REAR REFLECTOR SUPPORT

Dieses nützliche aerteil ermöglicht es Ihnen, den Original-Rückstrahler an der Nummernschildhalterung zu befestigen. Benutzen Sie bitte 2 Nieten oder Schrauben zur Fixierung an der Unterseite der Kennzeichenplatte.

This useful gadget allows you to place the original reflector on your bike's license plate support. To assemble, use two long rivets or screws and fit them on the bottom of the plate. To know about the right size for each country visit our web site.

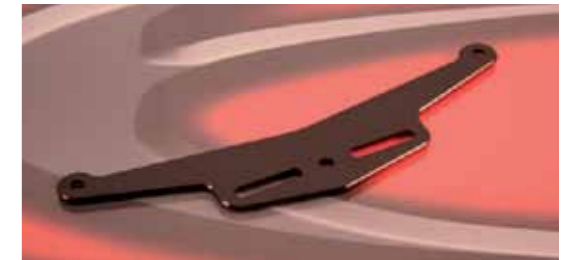

ELT-003 5,00

LED-RÜCKLICHT / REAR STOP LED LIGHT

Dieses homologierte LED-Rücklicht ist die optimale Lösung um Ihrem Motorrad ein individuelleres Aussehen zu geben. Durch seine Bauform passt es perfekt an viele Motorräder. Auslieferung erfolgt ohne Stecker. Kabel müssen evtl. gekürzt oder verlängert werden.

This homologated rear light is the best solution to personalize your motorbike. Its shape makes it perfect for many motorbikes. It is shipped without connector and with cut cables.

ABMESSUNGEN/ MEASURES	
max. Breite / maximum width	140 mm
max. Länge / maximum length	85 mm
max. Höhe / maximum height	40,3 mm
Schraubendurchmesser/ fixing screws diameter	6 mm
Schraubenabstand / fixing screws wheelbase	110 mm



ELT-004 50,00

KENNZEICHENHALTER TAIL TIDY

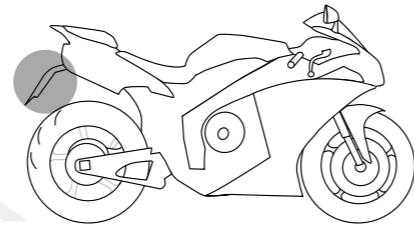

ADAPTER FÜR ZUBEHÖRBLINKER/ INDICATORS LIGHT ADAPTERS

Durch dieses nützliche Bauteil können Sie passende Zubehörblinker montieren. Das Angebot umfasst zwei Teile, die in Aluminium gefertigt sind. Die Form entspricht dem Querschnitt des Schaftes der Originalblinker. Somit kann der Adapter passgenau montiert werden. Sie sind in 4 verschiedenen Farben erhältlich. Bitte besuchen Sie unsere um die verschiedenen Anbaumöglichkeiten zu sehen.



Through this useful gadget you can fit the aftermarket indicators. This kit includes two caps machined from aluminium whose shape is the same as the original indicators shank. This allows you the correct fitting of threaded indicators' shank. They are available in 4 different colours. Visit our web site for the applications.



**5 JAHRE GARANTIE
5 YEARS WARRANTY**

CODE	FARB/CODE/COLOUR				EURO w/o tax
AFIL-01	Dn	Rg	Cr	Eb	12,00
AFIL-02	Dn	Rg	Cr	Eb	12,00
AFIL-03	Dn	Rg	Cr	Eb	12,00
AFIL-04	Dn	Rg	Cr	Eb	12,00
AFIL-05	Dn	Rg	Cr	Eb	12,00
AFIL-06	Dn	Rg	Cr	Eb	12,00
AFIL-07	Dn	Rg	Cr	Eb	12,00
AFIL-08	Dn	Rg	Cr	Eb	12,00

ADAPTER FÜR ORIGINALBLINKER/ SUPPORTS FOR ORIGINAL INDICATORS LIGHT

Dieses hochwertige Zubehör eignet sich optimal zum Anbau der Originalblinker an Evotech Kennzeichenhalter. Sie werden aus speziellem Aluminium aus der Luftfahrtindustrie gefräst und dann gekantet. Diese Adapter für Originalblinker sind für verschiedene Motorradmodelle verfügbar. Besuchen Sie unsere Website zur Wahl des richtigen Modells.



This high quality accessory, is perfect for those who want to maintain the original indicators light on the Evotech tail tidy. They are first machined from billet aluminium through CNC machineries and then they are being bent. Indicators supports are available for the different model bikes. Visit our web site for the correct model choice.

**5 JAHRE GARANTIE
5 YEARS WARRANTY**

MARKE/BRAND	CODE	EURO w/o tax
kit fzubehörblinker	SFK-01	5,00
APRILIA	SFO-10-A	6,50
BENELLI TNT	SFO-06-A	6,50
BMW	SFO-10-A	6,50
DUCATI (old models)	SFO-10-A	6,50
DUCATI (new models)	SFO-08-A	6,50
HONDA	SFO-01-A	6,50
MV AGUSTA	SFO-05-A	6,50
KAWASAKI	SFO-04-A	6,50
KTM	SFO-09-A	6,50
SUZUKI	SFO-03-A	6,50
TRIUMPH	SFO-10-A	6,50
YAMAHA	SFO-02-A	6,50

STURZPADS DEFENDER DEFENDER FRAME SLIDERS

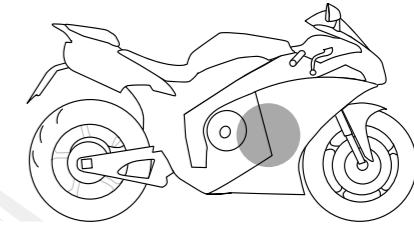

Diese sog. Aluminium Frame Slider (unterer Schaft) sind aus speziellem Aluminium aus der Luftfahrtindustrie gefräst. Das tiefe Bohrloch ermöglicht Ihnen die Steifigkeit des Bauteils zu regulieren, und die Beanspruchung des Rahmens zu reduzieren. Auf diese Weise wird die Gefahr einer Beschädigung des Motorradrahmens deutlich verringert. Jeder Slider hat eine Artikelnummer die Ihnen eine Nachbestellung bei Bedarf vereinfacht.

Aluminium frame sliders machined from billet aluminum through CNC machines. The hole, which is particularly deep, allows you to regulate the rigidity and to reduce frame stress. In this way the possibility that your frame breaks is reduced. Each slider has a number printed under it which enables you to recognize it and replace it when necessary.

**5 JAHRE GARANTIE
5 YEARS WARRANTY**

Die Kappe besteht aus einem speziellen Kunststoff. Dieses Material hat einen idealen Reibungskoeffizienten und ist ursächlich dafür, dass das Motorrad beim Fallen nicht zum Überschlagen neigt. Die Kappen sind an deren Oberfläche gelasert. Ihre besondere Form macht sie unvergleichbar. Jeder Frame Slider Kit hat zwischen dem Schaft und der Kappe einen O-Ring, der den Verlust der Kappe im Fahrbetrieb verhindert.

The Derlyn Plug is machined from special plastic material. This material has a low friction coefficient and allows the motorbike to stop gradually during the fall reducing the risk of a roll over. Derlyn plugs have been screen printed by laser. Their unique shape makes our plug esthetically incomparable. Each defender kit has an o-ring placed between the plastic plug and the aluminium pad which prevents the loss of the plug during the driving.



Der sogenannte OPEN-CLOSE Pack ermöglicht es Ihnen, die Ware aus der Verpackung zu nehmen, ohne dass sie beschädigt wird. Eine spezielle Einlage verhindert das Verkratzen beim Transport. Durch die Bezeichnungen L (LINKS) und R (RECHTS) wird die Seite des Motorrades vorgegeben, da dem der Frame Slider montiert werden soll. Die Anbauanleitung und Bilder zum Anbau am Motorrad finden Sie auf unserer Website.

Comfortable open-close pack which allows you to get out and show the product without breaking the packaging. There is a separating anti-scratch card which protects the product against any bumpy knocks during the transport. The L and R letters sign the motorbike side on which the pad has to be assembled (R=right, L=left). For assembling instruction and images about the motorbike and its accessories visit our web site.



STURZPAD DEFENDER DEFENDER FRAME SLIDERS

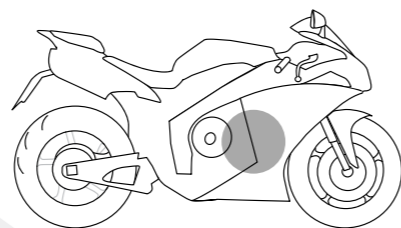

MARKE/BRAND	MODELL/MODEL	JAHR/YEAR	DRILLING SIDE	FARBCODE/COLOUR	CODE	EURO w/o tax	
BENELLI	TnT 1130 / 900/899	'05-'10		schwarz / Black	DEF0601	60,00	
	Tre 1130 K	'06-'10		schwarz / Black	DEF0602	60,00	
HONDA	HORNET 600	'98-'06		schwarz / Black	DEF0101	42,00	
	CBF 600 / N	'04-'07		schwarz / Black	DEF0101	42,00	
	HORNET 600	'07-'10		schwarz / Black	DEF0109	42,00	
	CBF 600 N / S	'08 >		schwarz / Black	DEF0109	42,00	
	CB 1000 R	'08-'10		schwarz / Black	DEF0110	42,00	
	HORNET 900	'01-'07		schwarz / Black	DEF0105	50,00	
	CBR 600 F / Sport	'99-'06	LX	RX	schwarz / Black	DEF0102	42,00
	CBR 600 RR	'03-'06	LX	RX	schwarz / Black	DEF0103	42,00
	CBR 600 RR	'07-'10	LX	RX	schwarz / Black	DEF0108	42,00
	CBR 900 RR	'00-'03			schwarz / Black	DEF0104	42,00
KAWASAKI	CBR 1000 RR	'04-'07	LX	RX	schwarz / Black	DEF0106	42,00
	CBR 1000 RR	'08-'10	LX	RX	schwarz / Black	DEF0111	42,00
	CBF 1000 / ST	'06-'10			schwarz / Black	DEF0107	42,00
	ZX 6R / RR	'03-'04			schwarz / Black	DEF0401	42,00
	ZX 6R / RR	'05-'06	LX		schwarz / Black	DEF0401	42,00
	ZX 6R	'07-'08		RX	schwarz / Black	DEF0405	42,00
	ZX 6R	'09	LX	RX	schwarz / Black	DEF0409	42,00
	Z 750	'04-'06			schwarz / Black	DEF0403	50,00
	Z 750	'07-'10			schwarz / Black	DEF0406	50,00
	Z 1000	'07-'09			schwarz / Black	DEF0406	50,00
MV AGUSTA	Z 1000	'10			schwarz / Black	DEF0410	50,00
	ZX 9R	'02-'04			schwarz / Black	DEF0404	42,00
	Z 1000	'03-'06			schwarz / Black	DEF0403	50,00
	ZX10R	'04-'05	LX	RX	schwarz / Black	DEF0402	42,00
	ZX10R*	'06-'07	LX	RX	schwarz / Black	DEF0402	42,00
	ZX10R	'08-'10	LX		schwarz / Black	DEF0407	42,00
	ZZR 1400	'07-'10			schwarz / Black	DEF0408	50,00
	F4 750 / 1000	<'09	LX	RX	schwarz / Black	DEF0501	42,00
	BRUTALE	<'09			schwarz / Black	DEF0501	42,00
	BRUTALE	'10			schwarz / Black	DEF0502	50,00
SUZUKI	GSX-R 600 / 750	'97-'99			schwarz / Black	DEF0301	42,00
	GSX-R 600 / 750	'00-'03	LX		schwarz / Black	DEF0301	42,00
	GSX-R 600 / 750	'04-'05			schwarz / Black	DEF0301	42,00
	GSX-R 600 / 750	'06-'10	LX		schwarz / Black	DEF0306	42,00
	GSX-R 1000	'00-'02	LX		schwarz / Black	DEF0301	42,00
	GSX-R 1000	'03-'04			schwarz / Black	DEF0301	42,00
	GSX-R 1000	'05-'06			schwarz / Black	DEF0305	42,00
	GSX-R 1000	'07-'08			schwarz / Black	DEF0308	42,00
	GSX-R 1000	'09-'10	LX	RX	schwarz / Black	DEF0312	42,00
	SV 650 naked / S	'00-'02			schwarz / Black	DEF0304	50,00
	SV 650 naked / S	'03-'07			schwarz / Black	DEF0302	50,00
	SV 650 naked / S	'08-'09			schwarz / Black	DEF0311	50,00
	SV 1000	'03-'08			schwarz / Black	DEF0303	50,00
	B-KING	'08-'10			schwarz / Black	DEF0310	42,00
	GSR 600	'06-'10			schwarz / Black	DEF0307	42,00
GLADIUS	'09 >			schwarz / Black	DEF0313	60,00	
TRIUMPH	Speed Triple	'99-'07			schwarz / Black	DEF0701	50,00
	Daytona	'99-'04			schwarz / Black	DEF0701	50,00
	Street Triple	'07-'09			schwarz / Black	DEF0702	50,00
YAMAHA	R1	'02-'03			schwarz / Black	DEF0203	42,00
	R1	'04-'06			schwarz / Black	DEF0204	42,00
	R6	'99-'02	LX	RX	silber / silver	DEF0205	42,00
	R6	'03-'05		RX	schwarz / Black	DEF0206	42,00
	R6	'06-'07	LX		schwarz / Black	DEF0208	42,00
	R6	'08-'10			schwarz / Black	DEF0210	42,00
	FZ6 / Fazer / S2	'04-'10			schwarz / Black	DEF0207	42,00
	FZ1 / Fazer / FZ8	'06-'10			schwarz / Black	DEF0209	42,00
XJ6	'09 >	LX	RX	schwarz / Black	DEF0212	42,00	
EVOTECH	ERSATZKAPPEN / SPARE PLUG				DEF0001	10,00	
	O-RING				DEF0002	0,50	

* it is necessary to replace the tank of radiator's fluid

STREET DEFENDER KIT

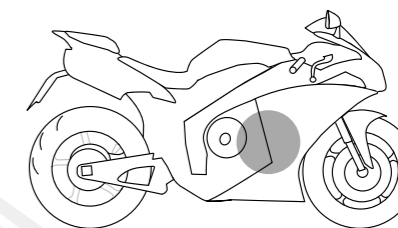

STREET DEFENDER KIT

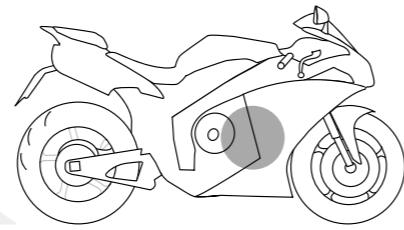

Die Defender Frame Slider bieten den optimalen Schutz nur dann, wenn sie an soliden Stellen (zum Beispiel Motoraufhängung), mit Schrauben von mindestens 10mm Durchmesser befestigt sind. An Motorrädern sind diese Stellen oftmals durch die Verkleidung verdeckt. In diesen Fällen wäre es notwendig, die Verkleidung zu modifizieren, um die Crash Pads montieren zu können. Frame Silders, die an anderen Stellen montiert werden, gewährleisten oftmals keinen Schutz beim Sturz. Aus diesem Grunde entwickelt Evotech lediglich für solche Motorräder Defender Frame Slider, an denen ein effizienter Schutz des Motorrades möglich ist. Sie ermöglichen optimalen Schutz des Motorrades ohne dass an der Motorradverkleidung Modifikationen vorgenommen werden müssen.

Defender frame sliders offer the greatest protection only when they are fitted on a solid point (frame-engine attachment) and through bolts with a large diameter (10mm at least). On some motorbikes these connection points are often hidden by the fairing. In this case it is necessary to modify it in order to assemble the crash pads. Frame sliders fixed on other points that are not so tough (frame brackets, etc) can't guarantee in case of fall a good protection. It is for all these reasons that Evotech, only for those motorbikes where the application is efficient, has created these kits. They allow to protect your bike in a very efficient way and without making any modification to the original fairing.



MARKE/BRAND	MODELL/MODEL	JAHR/YEAR	CODE/CODE	EURO w/o tax
APRILIA	TUONO R / FACTORY	'06 -'09	STD-A01	100,00
	RSV4	'09-'10	STD-V4	150,00
BMW	S1000RR	'10 >	STD-S1000	120,00
DUCATI	Monster 696 / 1100	'08 -'10	STD-D1*	179,00
<small>*anderer Rabatt / different discount</small>				
HONDA	CBR 600 RR	'07 -'08	STD-H06	120,00
	CBR 1000 RR	'05	STD-H10	120,00
	CBR 1000 RR	'06 -'07	STD-H11	120,00
KAWASAKI	ZX6R / RR	'05 -'06	STD-K6	80,00
	ZX6R	'07 -'08	STD-K7	80,00
	ZX6R	'09	STD-K8	120,00
	Z750	'07 -'10	STD-K12	90,00
	Z1000	'07 -'09	STD-K12	90,00
	ER6-N	'06 -'08	STD-ER6	80,00
	VERSYS	'07 -'09	STD-ER6	80,00
KTM	SUPERMOTO 990	'09 >	STD-SM990	100,00
	SUPERDUKE 990	'09 >	STD-SDUKE	100,00
SUZUKI	GSX-R 600 / 750	'06 -'07	STD-GX	100,00
	GSX-R 600 / 750	'08 -'10	STD-GX2	100,00
TRIUMPH	DAYTONA 675	'06 -'10	STD-T675	150,00
	STREET TRIPLE	'07 -'10	STD-T675	150,00
	SPEED TRIPLE	'08 -'10	STD-SPEED	100,00
	TIGER 1050	'07 -'10	STD-TIGER	150,00
YAMAHA	R6	'03 -'05	STD-Y6	80,00
	R6	'06 -'07	STD-Y8	100,00
	R1	'07 -'08	STD-Y9	100,00
	R1	'09 -'10	STD-Y11	120,00
	XJ6	'09 -'10	STD-Y10	90,00

ZUBEHÖRTEILE SPARE PARTS

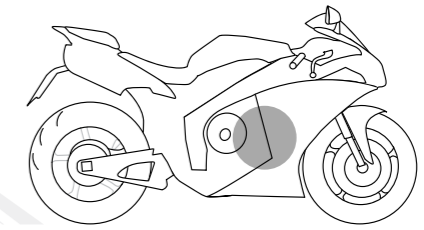

KIT	BESCHREIBUNG/DESCRIPTION	CODE/CODE	EURO w/o tax
APRILIA TUONO '06 -'09	Halterung Rechts / Right bracket	STR-A01	50,00
	Linker Aluminium Frame Slider / LEFT alu frame slider	TG-47B	10,00
	Rechte Slider Schraube / Right slider's bolt	M10X90	3,00
	Rechter Aluminium Frame Slider / Righty alu frame slider	TG-15B	10,00
	Rechte Unterlage / Right spacer	STR-A01-D	3,00
	Linke Slider Schraube / Left slider's bolt	M10x140 1.5	3,00
APRILIA RSV4 '09-'10	Halterung Rechts / Right bracket	STR-RV4-SR	56,00
	Halterung Links / Left bracket	STR-RV4-SL	56,00
	Rechter Aluminium Frame Slider / Right alu frame slider	TG-07B	10,00
	Linker Aluminium Frame Slider / Left alu frame slider	TG-06B	10,00
	Rechte Slider Schraube / Right slider's bolt	M10X40	3,00
	Linke Slider Schraube / Left slider's bolt	M10X40	3,00
	Linke Halterschraube / Left bracket's bolt	M10X75 1.5	3,00
	Rechte Halterschraube / Right bracket's bolt	M10X90 1.5	3,00
	Unterlage Halterung/bracket spacer	STR-RV4-B1	12,00
Unterlage Halterung/bracket spacer	STR-RV4-B2	12,00	
BMW S1000RR '10	Halterung Rechts / Right bracket	STR-S1000-SR	55,00
	Halterung Links / Left bracket	STR-S1000-SL	55,00
	Rechter Aluminium Frame Slider / Right alu frame slider	TG-33B	10,00
	Linker Aluminium Frame Slider / Left alu frame slider	TG-33B	10,00
	Rechte Slider Schraube / Right slider's bolt	M10X50	3,00
	Linke Slider Schraube / Left slider's bolt	M10X50	3,00
	Linke Halterschraube / Left bracket's bolt	M10X60 1.5	3,00
DUCATI MONSTER 696/1100	Halterung Rechts / Right bracket	STR-MON-SR	68,00
	Halterung Links / Left bracket	STR-MON-SL	68,00
	Rechter Aluminium Frame Slider / Right alu frame slider	TG-42B	10,00
	Linker Aluminium Frame Slider / Left alu frame slider	TG-07B	10,00
	Rechte Slider Schraube / Right slider's bolt	M10X40	3,00
	Linke Slider Schraube / Left slider's bolt	M10X40	3,00
	Special bolts RX-LX / Special right and left spacer	STR-MON-V	14,00
	Linke Unterlage / Left spacer	STR-MON-B1	11,00
	Rechte Unterlage / Right spacer	STR-MON-B2	11,00
Edelstahl Bolzen / Inox bolt	STR-MON-P	24,00	
HONDA CBR 600 RR '07 -'08	Halterung Links / Left bracket	STR-H06SL	55,00
	Halterung Rechts / Right bracket	STR-H06SR	55,00
	Linker Aluminium Frame Slider / Left alu frame slider	DEF0033	10,00
	Rechter Aluminium Frame Slider / Right alu frame slider	DEF0006	10,00
	Linke Slider Schraube / Left slider's bolt	M10X50	3,00
	Rechte Slider Schraube / Right slider's bolt	M10X50	3,00
HONDA CBR 1000 RR '05	Halterung Links / Left bracket	STR-H10SL	45,00
	Halterung Rechts / Right bracket	STR-H10SR	45,00
	Aluminium frame slider	DEF0020	10,00
	Linke Halterschraube / Left bracket's bolt	M12X70	3,00
	Rechte Halterschraube / Right bracket's bolt	M12X80	3,00
	Schraube slider / Frame slider's bolt	M10X40	3,00
Schraube M6 / M6 bracket's bolt	M6X20	1,00	

**5 JAHRE GARANTIE
5 YEARS WARRANTY**

ZUBEHÖRTEILE SPARE PARTS

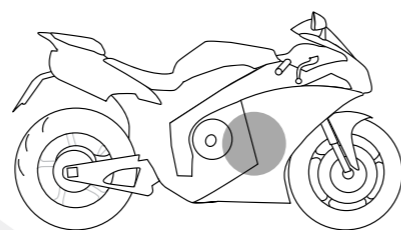

KIT	BESCHREIBUNG / DESCRIPTION	CODE/CODE	EURO w/o tax
HONDA CBR 1000 RR '06 -'07	Halterung Links / Left bracket	STR-H11SL	45,00
	Halterung Rechts / Right bracket	STR-H11SR	45,00
	Aluminium frame slider	DEF0020	10,00
	Linke Halterschraube / Left bracket's bolt	M12X80	3,00
	Rechte Halterschraube / Right bracket's bolt	M12X90	3,00
	Schraube frame slider / Frame slider's bolt	M10X40	3,00
	Verkleidungsadapter / Fairing spacer	STR-H11D	2,00
KAWASAKI ZX6R/RR '05 -'06	Halterung Links / Left bracket	STR-K6S	40,00
	Bullone di fissaggio staffa / Bracket's bolt	M10X70	3,00
	Linker Aluminium Frame Slider / Left frame slider	DEF0017	10,00
	Rechter Aluminium Frame Slider / Right frame slider	DEF0016	10,00
	Linke Slider Schraube / Left slider's bolt	M10X70	3,00
	Rechte Slider Schraube / Right slider's bolt	M10X100	3,00
KAWASAKI ZX6R '07 -'08	Halterung Rechts / Right bracket	STR-K7D	40,00
	Schraube Halterung / Bracket's bolt	M10X70	3,00
	Linker Aluminium Frame Slider / Left frame slider	DEF0019	10,00
	Rechter Aluminium Frame Slider / Right frame slider	DEF0009	10,00
	Linke Slider Schraube / Left slider's bolt	M10X100	3,00
KAWASAKI ZX6R '09	Halterung Links / Left bracket	STR-K8SL	40,00
	Halterung Rechts / Right bracket	STR-K8SR	40,00
	Linke Halterschraube / Left bracket's bolt	M10X50	3,00
	Rechte Halterschraube / Right bracket's bolt	M10X60	3,00
	Spezielle Ringmutter / special ring nut	STR-K8-G	2,00
KAWASAKI ER - 6N / VERSYS	frame slider LX / Left frame slider	DEF0042	10,00
	frame slider RX / Right frame slider	DEF0037	10,00
	Linke Slider Schraube / Left slider's bolt	M10X50	3,00
	Rechte Slider Schraube / Right slider's bolt	M10X60	3,00
	Halterung Links / Left bracket	STR-ER6SL	20,00
	Halterung Rechts / Right bracket	STR-ER6SR	20,00
	Linke Halterschraube / Left bracket's bolt	M10X60	3,00
	Rechte Halterschraube / Right bracket's bolt	M10X100	3,00
KAWASAKI ER-6N '09	Linker Aluminium Frame Slider / Left alu frame slider	DEF0023	10,00
	Rechter Aluminium Frame Slider / Right alu frame slider	DEF0042	10,00
	Linke Slider Schraube / Left slider's bolt	M10X60	3,00
	Rechte Slider Schraube / Right sliders's bolt	M10X40	3,00
	Halterung Rechts / Right bracket	STR-ER62SR	20,00
	Rechte Halterschraube / Right bracket's bolt	M10X80	3,00
KAWASAKI Z750 '07- '10	Linker Aluminium Frame Slider / Left alu frame slider	DEF0023	10,00
	Rechter Aluminium Frame Slider / Right alu frame slider	DEF0042	10,00
	Linke Slider Schraube / Left slider's boltw	M10X60	3,00
	Rechte Slider Schraube / Right slider's bolt	M10X40	3,00
	Halterung Rechts / Right bracket	STR-K12	40,00
	Halterung Links / Left bracket	STR-K12	40,00
	Schraube Halterung / Bracket's bolt	TCCE M8X50	3,00

ZUBEHÖRTEILE SPARE PARTS

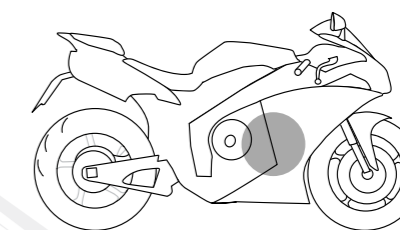

KIT	BESCHREIBUNG / DESCRIPTION	CODE/CODE	EURO w/o tax
KTM SUPERMOTO 990	Halterung Rechts / Right bracket	STR-LC8	45,00
	Halterung Links / Left bracket	STR-LC8	45,00
	Rechter Aluminium Frame Slider / Right alu frame slider	TG-23B	10,00
	Linker Aluminium Frame Slider / Left alu frame slider	TG-23B	10,00
	Rechte Slider Schraube / Right slider's bolt	M10X60	3,00
	Linke Slider Schraube / Left slider's boltw	M10X60	3,00
	Schraube Halterung / Bracket's bolt	M10X40 1.5	3,00
	KTM 990 SUPERDUKE/R	Halterung Rechts / Right bracket	STR-LC8
Halterung Links / Left bracket		STR-LC8	45,00
Rechter Aluminium Frame Slider / Right alu frame slider		TG-23B	10,00
Linker Aluminium Frame Slider / Left alu frame slider		TG-19B	10,00
Rechte Slider Schraube / Right slider's bolt		M10X60	3,00
Linke Slider Schraube / Left slider's boltw		M10X60	3,00
Bullone di fissaggio staffa / Bracket's bolt		M10X40 1.5	3,00
SUZUKI GSX-R 600 / 750 '06 -'07	Halterung Links / Left bracket	STR-GX	60,00
	Schraube Halterung / Bracket's bolt	M10X60	3,00
	Linker Aluminium Frame Slider / Left frame slider	DEF0007	10,00
	Rechter Aluminium Frame Slider / Right frame slider	DEF0020	10,00
	Linke Slider Schraube / Left slider's bolt	M10X50	3,00
SUZUKI GSX-R 600 / 750 '08 -'09	Rechte Slider Schraube / Right slider's bolt	M10X70	3,00
	Halterung Links / Left bracket	STR-GX2	60,00
	Schraube Halterung / Bracket's bolt	M10X60	3,00
	Linker Aluminium Frame Slider / Left frame slider	DEF0007	10,00
	Rechter Aluminium Frame Slider / Right frame slider	DEF0020	10,00
TRIUMPH DAYTONA 675	Linke Slider Schraube / Left slider's bolt	M10X50	3,00
	Rechte Slider Schraube / Right slider's bolt	M10X70	3,00
	Halterung Links / Left bracket	STR-T6S	50,00
	Halterung Rechts / Right bracket	STR-T6D	50,00
	Unterlage LX / Left spacer	STR-T6LD	8,00
	Unterlage RX / Right spacer	STR-T6RD	8,00
	Schraube Halterung Links / Left bracket's bolt	M10X120	3,00
	Schraube Halterung Rechts / Right bracket's bolt	M10X120	3,00
YAMAHA R6 '03 -'05	Linker Aluminium Frame Slider / Left frame slider	DEF0041	10,00
	Rechter Aluminium Frame Slider / Right frame slider	DEF0007	10,00
	Rechte Slider Schraube / Right slider's bolt	M10X40	3,00
	Linke Slider Schraube / Left slider's bolt	M10X70	3,00
	Halterung Rechts / Right bracket	STR-Y6S	40,00
	Schraube Halterung / Bracket's bolt	M10X50	3,00
YAMAHA R6 '06 -'07	Linker Aluminium Frame Slider / Left frame slider	DEF0033	10,00
	Rechter Aluminium Frame Slider / Right frame slider	DEF0006	10,00
	Linke Slider Schraube / Left slider's bolt	M10X60	3,00
	Rechte Slider Schraube / Right slider's bolt	M10X50	3,00
	Halterung Links / Left bracket	STR-Y8	60,00
	Schraube Halterung / Bracket's bolt	M10X60	3,00
	Linker Aluminium Frame Slider / Left frame slider	DEF0017	10,00
	Rechter slider / Right frame slider	DEF0007	10,00
YAMAHA R6 '06 -'07	Linke Slider Schraube / Left slider's bolt	M10X70	3,00
	Rechte Slider Schraube / Right slider's bolt	M10X70	3,00

ZUBEHÖRTEILE SPARE PARTS

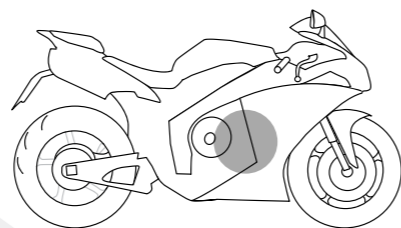

KIT	BESCHREIBUNG/DESCRIPTION	CODE/CODE	EURO w/o tax
YAMAHA R1 '07-'08	Halterung Links / Left bracket	STR-Y9SL	40,00
	Halterung Rechts / Right bracket	STR-Y9SR	40,00
	Linke Halterschraube / Left bracket's bolt	M10X60	3,00
	Schraube Ölwanne-Halterung Lx / LX bracket cover's screw	M6X35	0,50
	Rechte Halterschraube / Right bracket's bolt	M10X60	3,00
	Linker Aluminium Frame Slider / Left frame slider	DEF0041	10,00
	Rechter Aluminium Frame Slider / Right frame slider	DEF0042	10,00
	Linke Slider Schraube / Left slider's bolt	M10X70	3,00
	Rechte Slider Schraube / Right slider's bolt	M10X40	3,00
YAMAHA R1 '09	Halterung Rechts / Right bracket	STR-Y11SR	45,00
	Halterung Links / Left bracket	STR-Y11SL	45,00
	Linke Halterschraube / Left bracket's bolt	M12X60	3,00
	Linker Aluminium Frame Slider / Left frame slider	DEF0020	10,00
	Rechter Aluminium Frame Slider / Right frame slider	DEF0037	10,00
	Linke Slider Schraube / Left slider's bolt	M10X40	3,00
	Rechte Slider Schraube / Right slider's bolt	M10X60	3,00
	Linke Unterlage / Left ferrule	STR-Y11-B1	1,50
Rechte Unterlage / Right ferrule	STR-Y11-B2	0,70	
YAMAHA XJ6 '09	Halterung Rechts / Right bracket	STR-Y10SR	40,00
	Halterung Links / Left bracket	STR-Y10SL	40,00
	Rechte Halterschraube / Right bracket's bolt	M6X35	4,00
	Rechter Aluminium Frame Slider / Right frame slider	DEF0020	10,00
	Rechte Slider Schraube / Right slider's bolt	M10X40	3,00
	Linke Halterschraube / Left bracket's bolt	M6X35	3,00
	Linker Aluminium Frame Slider / Left frame slider	DEF0042	10,00
Linke Slider Schraube / Left slider's bolt	M10X40	3,00	
SPEED TRIPLE	Halterung Rechts / Right Bracket	STR-SPEED	40,00
	Rechte Halterschraube / Right bracket's bolt	M12X70	3,00
	Rechter Aluminium Frame Slider / Right frame slider	DEF0039	10,00
	Rechte Slider Schraube / Right slider's bolt	M12X80	3,00
	Linker Aluminium Frame Slider / Left frame slider	DEF0038	10,00
	Linke Slider Schraube / Left slider's bolt	M12X120	3,00
TIGER 1050	Halterung Rechts / Right bracket	STR-TIGERSR	40,00
	Halterung Links / Left Bracket	STR-TIGERSL	40,00
	Rechte Halterschraube / Right bracket's bolt	M12x80	3,00
	Rechter Aluminium Frame Slider / Right frame slider	DEF0018	10,00
	Rechte Slider Schraube / Right slider's bolt	M10X80	3,00
	Linke Halterschraube / Left bracket's bolt	M12X50	3,00
Linker Aluminium Frame Slider / Left frame slider	DEF0018	10,00	

ALUMINIUM ÖSENSCHRAUBEN ALUMINIUM PLUGS

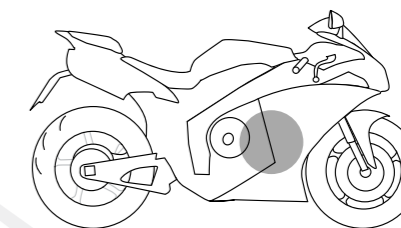

Durch den Tausch der Kappen am Frame Slider, erhält man mit diesen speziellen Ösenschrauben optimale Haltepunkte zur Abspannung des Motorrades beim Transport. Dank der Fertigung aus einem Stück und besonders festem Material, sind die Ösenschrauben absolut stabil. Die grossen Löcher in den Ösenschrauben ermöglichen den Einsatz breiter Spannbänder oder Spannbügel. So verhindern Sie Kratzer in der Verkleidung, durch Spanngurte, die an der Verkleidung scheuern. Ebenfalls verhindern Sie Beschädigungen an den Griffen des Lenkers, durch Spanngurte mit Schlaufen, die über die Griffe gestülpt werden.

By replacing the derlyn plugs with this special aluminium plugs, the frame sliders become the safest and most practical system to tie your motorbike on the van! Say stop to the scratches on the fairing panels made by the belts make, semi-handlebars, fairing, say stop to those tie systems on the grips that little by little will ruin them! Great resistance thanks to the working of a single block of a special alloy by sophisticated numerical control machineries. The hole has a big diameter to allow the passage of big cables or belts.

**5 JAHRE GARANTIE
5 YEARS PRODUCTS GUARANTEE**



PROTECTOR

MOTORSCHÜTZER

ENGINE PROTECTOR

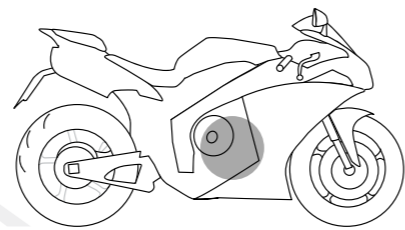

Auch wenn bei einem Sturz die meisten Schäden durch unsere Street Defender vermieden werden, benötigt der Motor bei einigen Motorrädern mehr Schutz. Die Einsatzkomponenten werden durch FEM-Analyse geprüft. Das Gewicht wird reduziert ohne dass Stabilität verloren geht. Bei einigen Rennserien haben sich solche Schutzvorrichtungen durchgesetzt, da stärkere Beschädigungen vermieden werden können. Aus diesem Grund entwickelt Evotech solche Bauteile, die funktionelle Aspekte, geringes Gewicht und Eleganz verbinden.

Even though during a fall our Street Defender avoid most damages, in some motorbikes the engine needs more defense. The components have been checked by FEM analysis to optimize its weight but keeping the best mechanical resistance in case of fall. Evotech chain guards have been thought because some championships in the motorcycle world establish a clause with the obligation to protect the engine parts which, in case of fall, might become perforated and dirty the course by losing the lubricant. For this reason Evotech decided to create this accessory that combines the functional aspects with the elegance and the originality typical of all our products.



5 JAHRE GARANTIE
5 YEARS WARRANTY

MARKE/BRAND	MODELL/MODEL	JAHR/YEAR	CODE/CODE	FARBCODE/COLOUR	EURO w/o tax
YAMAHA	R1	'04-'06	PRO 0204	Dn / /	36,00
	R6	'06-'10	PRO 0210	Dn / /	40,00
KAWASAKI	ZX6R	'09 >	PRO 0469-A	Dn / /	80,00
	ZX6R	'09 >	PRO 0469-B	Dn Si Rg	100,00
	ZX6R	'09 >	PRO 0469-C	Dn / /	190,00

GEMS OF THE WIND

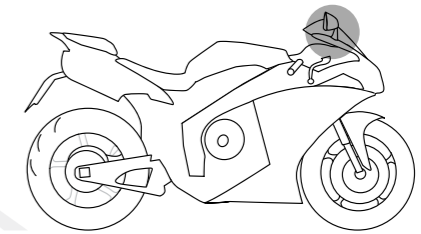

Wenn Sie auf der Rennstrecke fahren werden die Original Spiegel entfernt. Dann stellt sich aber die Frage, wie die Verkleidung an den Haltepunkten der Spiegel befestigt werden und die Löcher sauber abgedeckt werden können. Diese Kleinen Tags sind die richtige Lösung. Diese passgenauen und formschönen Teile erfüllen Ihre Wünsche. Sie können unter 6 verschiedenen Farben wählen. Mit dem Evotech-Logo und vollendeter Oberfläche sind diese Teile ein Blickfang auf der Rennstrecke oder auf Veranstaltungen oder speziellen Umbauten bei denen die Original Spiegel demontiert werden.

To drive on a track it is advisable to take off the original mirrors. But how can You fix the original fairing to the frame hiding the not so attractive holes that will remain? These small tags are the right solution. We have given them the aspect of real precious gems, and here comes their name. Gems of the wind! You can choose among 6 different gleaming colours, all with their silk screen, giving them a refined touch to Your motorbike while on the track, or in any occasion in which you want to show it off (sporting events, fairs etc..)

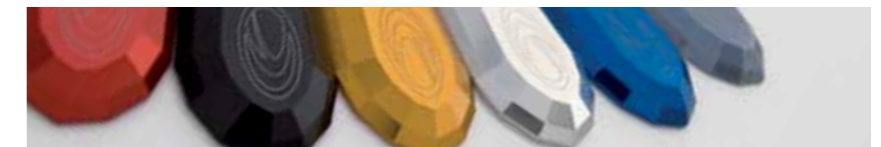

5 JAHRE GARANTIE
5 YEARS WARRANTY

MARKE/BRAND	MODELL/MODEL	JAHR/YEAR	CODE/CODE	FARBCODE/COLOUR	EURO w/o tax
APRILIA	RSV4 FACTORY/R	/	GW-V4	Si Dn Ti Rg Cr Eb	32,00
BMW	S1000RR	'09 >	GW-YA3	Si Dn Ti Rg Cr Eb	32,00
HONDA	HORNET 600 S	'98-'06	GW-HO	Si Dn Ti Rg Cr Eb	32,00
	CBR 600 F	'99-'06	GW-HO	Si Dn Ti Rg Cr Eb	32,00
	CBR 600 RR	'03-'10	GW-HO	Si Dn Ti Rg Cr Eb	32,00
	CBR 929 RR	'00-'01	GW-HO	Si Dn Ti Rg Cr Eb	32,00
	CBR 954 RR	'02-'03	GW-HO	Si Dn Ti Rg Cr Eb	32,00
	VTR SP 1/2	/	GW-HO	Si Dn Ti Rg Cr Eb	32,00
	CBR 1000 RR	'04-'07	GW-HO	Si Dn Ti Rg Cr Eb	32,00
KAWASAKI	ZX6R/RR	'03-'04	GW-KA1	Si Dn Ti Rg Cr Eb	32,00
	ZX6R	'09 >	GW-KA3	Si Dn Ti Rg Cr Eb	32,00
	ER-6F	'06-'08	GW-KA1	Si Dn Ti Rg Cr Eb	32,00
	ZX6R/RR	'05-'08	GW-KA2	Si Dn Ti Rg Cr Eb	32,00
	ZX10R	'04-'10	GW-KA2	Si Dn Ti Rg Cr Eb	32,00
SUZUKI	GSX-R 600/750	'00-'05	GW-SU	Si Dn Ti Rg Cr Eb	32,00
	GSX-R 1000	'00-'04	GW-SU	Si Dn Ti Rg Cr Eb	32,00
	GSX-R 600/750	'06-'10	GW-S2	Si Dn Ti Rg Cr Eb	32,00
	GSX-R 1000	'05-'10	GW-S2	Si Dn Ti Rg Cr Eb	32,00
	SV 650 S	'00-'09	GW-SU	Si Dn Ti Rg Cr Eb	32,00
	SV 1000 S	'03-'08	GW-SU	Si Dn Ti Rg Cr Eb	32,00
YAMAHA	R1	'98-'06	GW-YA	Si Dn Ti Rg Cr Eb	32,00
	R6	'99-'07	GW-YA	Si Dn Ti Rg Cr Eb	32,00
	R6	'08-'10	GW-YA2	Si Dn Ti Rg Cr Eb	32,00
	R1	'09 >	GW-YA3	Si Dn Ti Rg Cr Eb	32,00
	R1	'07-'08	GW-KA1	Si Dn Ti Rg Cr Eb	32,00
	FAZER 1000	'02-'03	GW-YA	Si Dn Ti Rg Cr Eb	32,00
	T-MAX	'07	GW-MAX	Si Dn / Rg Cr Eb	45,00

FINAL STORM

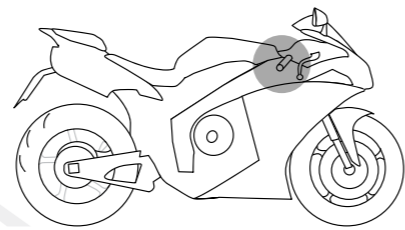

Lenkerendengewichte aus speziellem Aluminium gefräst. Sie haben ein innovatives Design bis ins letzte Detail. Der Aufnahme punkt entspricht dem des Originals. Aus diesem Grund ist der Anbau sehr einfach und schnell. Die Schrauben sind im leichten aber hochfesten Duraluminium gefertigt, und im gleichen Farbton wie die Lenkerendengewichte eloxiert. Sie können aus 6 verschiedenen Farbtönen wählen.

Bar end counterbalances machined from billet aluminium.
They boast a definitely innovative design and the maximal carefulness in each detail .The attach point is the same as the original one, for this reason the assembly is easy and fast.
The bolts are made of anodized ergal in the same colour of the bar ends.
You can choose among 6 wonderful anodized colours.



MARKE/BRAND	MODELL/MODEL	JAHR/YEAR	CODE/CODE	FARB/CODE/COLOUR	EURO w/o tax
	UNIVERSALE/ UNIVERSAL		FS-U	Si Dn Ti Rg Cr Eb	22,50
APRILIA	TUONO/ RSV/ RSV4	'05-'10	FS-BE	Si Dn Ti Rg Cr Eb	22,50
	RS 125	'07-'10	FS-SU	Si Dn Ti Rg Cr Eb	22,50
	SHIVER	'08-'08	FS-BE	Si Dn Ti Rg Cr Eb	22,50
	SHIVER	'09-'10	FS-SU	Si Dn Ti Rg Cr Eb	22,50
BENELLI	TnT/ Trek	/	FS-BE	Si Dn Ti Rg Cr Eb	22,50
DUCATI	Alle außer ST2 e S4/ except for ST2,S4		FS-U	Si Dn Ti Rg Cr Eb	22,50
HONDA	HORNET 600/ 900	tutte/ all	FS-HO	Si Dn Ti Rg Cr Eb	22,50
	CBR 600 F/ Sp	'99-'06	FS-HO	Si Dn Ti Rg Cr Eb	22,50
	CBR 600 RR	'03-'10	FS-HO	Si Dn Ti Rg Cr Eb	22,50
	CBR 900 RR	'00-'03	FS-HO	Si Dn Ti Rg Cr Eb	22,50
	VTR SP1/ 2	'01-'03	FS-HO	Si Dn Ti Rg Cr Eb	22,50
	CB 1300	'08-'10	FS-HO	Si Dn Ti Rg Cr Eb	22,50
	CB 1000 R	'08-'10	FS-HO	Si Dn Ti Rg Cr Eb	22,50
	CBF 600/ N	'08-'10	FS-HO	Si Dn Ti Rg Cr Eb	22,50
	CBR 1000 RR	'04-'10	FS-HO	Si Dn Ti Rg Cr Eb	22,50
	KAWASAKI	ZX6R/ RR	'98-'06	FS-KA1	Si Dn Ti Rg Cr Eb
ZX6R		'07-'10	FS-KA2	Si Dn Ti Rg Cr Eb	22,50
ZX9R		'00-'04	FS-KA1	Si Dn Ti Rg Cr Eb	22,50
Z1000/ 750		'03-'10	FS-KA1	Si Dn Ti Rg Cr Eb	22,50
ZX10R		'04-'10	FS-KA2	Si Dn Ti Rg Cr Eb	22,50
ER-6N/ F - VERSYS		'06-'10	FS-KA1	Si Dn Ti Rg Cr Eb	22,50
MV AGUSTA	F4/ BRUTALE	< '09	FS-MV	Si Dn Ti Rg Cr Eb	22,50
	BRUTALE	'10	FS-U	Si Dn Ti Rg Cr Eb	22,50

FINAL STORM

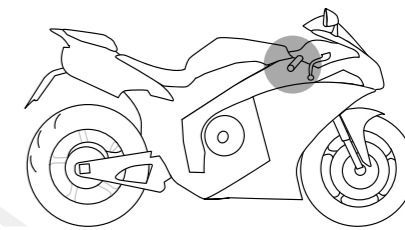

Lenkerendengewichte aus speziellem Aluminium gefräst. Sie haben ein innovatives Design bis ins letzte Detail. Der Aufnahme punkt entspricht dem des Originals. Aus diesem Grund ist der Anbau sehr einfach und schnell. Die Schrauben sind im leichten aber hochfesten Duraluminium gefertigt, und im gleichen Farbton wie die Lenkerendengewichte eloxiert. Sie können aus 6 verschiedenen Farbtönen wählen.

Final Storm barends are constructed from stainless steel and aircraft grade aluminum.
Bmw final Storm are designed according to the OEM components, but give beautiful personalization to your BMW while maintaining the OEM design intentions. Inertial main body manufactured in stainless steel; the special ring machined from aircraft grade, billet aluminium, assembled using the highest quality Ergal bolt.
Weight: from 200 to 235 grams



MARKE/BRAND	MODELL/MODEL	CODE/CODE	COLORI/COLOUR	EURO w/o tax
BMW	K1200S/R/Sport - K1300S/R	FS-BMW1	Si Dn Ti Rg Cr Eb	70,00
	F800 R, R1200 ST, F650 GS *	FS-BMW2	Si Dn Ti Rg Cr Eb	70,00
	R1200 GS, R1100 GS	FS-BMW3	Si Dn Ti Rg Cr Eb	80,00
	R850 R, R1100 R, R1150 R, K1200 GT	FS-BMW4	Si Dn Ti Rg Cr Eb	70,00
	S1000 RR	FS-BMW5	Si Dn Ti Rg Cr Eb	/

* nur ohne Handschützer / only without hand protectors

MARKE/BRAND	MODELL/MODEL	JAHR/YEAR	CODE/CODE	COLORI/COLOUR	EURO w/o tax
KTM	Superduke 990/690 SMC	/	FS-U	Si Dn Ti Rg Cr Eb	22,50
SUZUKI	GSX-R 600/ 750	'00-'05	FS-U	Si Dn Ti Rg Cr Eb	22,50
	GSX-R 1000	'00-'04	FS-U	Si Dn Ti Rg Cr Eb	22,50
	GSX-R 600/ 750	'06-'10	FS-SU	Si Dn Ti Rg Cr Eb	22,50
	GSX-R 1000	'05-'10	FS-SU	Si Dn Ti Rg Cr Eb	22,50
	SV 650 S	'00-'10	FS-U	Si Dn Ti Rg Cr Eb	22,50
	SV 1000 S	'03-'10	FS-U	Si Dn Ti Rg Cr Eb	22,50
	GSR 600	'06-'10	FS-U	Si Dn Ti Rg Cr Eb	22,50
	B-King	'08-'10	FS-U	Si Dn Ti Rg Cr Eb	22,50
	Gladius	/	FS-SU	Si Dn Ti Rg Cr Eb	22,50
TRIUMPH	SPEED TRIPLE	'05-'10	FS-U	Si Dn Ti Rg Cr Eb	22,50
YAMAHA	R1	'98-'10	FS-YA1	Si Dn Ti Rg Cr Eb	22,50
	R6	'99-'05	FS-YA2	Si / / Rg / /	22,50
	FZ6	'04-'10	FS-YA3	Si Dn Ti Rg Cr Eb	22,50
	FAZER 1000	'02-'04	FS-YA3	Si Dn Ti Rg Cr Eb	22,50
	TDM 900/ T-Max	/	FS-YA3	Si Dn Ti Rg Cr Eb	22,50
	R6	'06-'10	FS-YA1	Si Dn Ti Rg Cr Eb	22,50
	FZ1 Naked/FZ8	'06-'10	FS-YA1	Si Dn Ti Rg Cr Eb	22,50
	FZ1 Fazer	'06-'10	FS-YA3	Si Dn Ti Rg Cr Eb	22,50
	XJ6	'09	FS-YA3	Si Dn Ti Rg Cr Eb	22,50

PADDOCK STANDS

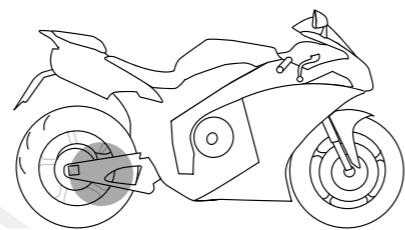

Diese Anbauteile werden aus einer, in der Luftfahrt angewendeten Aluminiumlegierung gefräst. Durch die Bearbeitung an CNC- gesteuerten Maschinen sind sportliche und sehr elegante Formen realisierbar. Der Stiel ist derselbe, wie bei unseren FINAL STORM Lenkerendengewichten. Aufgrund ihres grossen Durchmessers und des besonderen Materials sind unsere Bolzen für Paddock Stands sehr stabil. Sie Schützen zudem beim Motorradtransport. Die Montage erfolgt mit einem Standard Innensechskant-Schlüssel. 5 Jahre Garantie

This component has been completely machined from a single block made of a special aeronautic alloy. Thanks to sophisticated numerical control machineries, these items boast a new design in any aspects, giving a sports and elegant touch to every motorbike, sports or naked ones. The style is the same as our "Final Storm" handlebar counterbalances giving the motorcycles that wear these two components a sophisticated fashion and a continuity of style. Evotech paddock stands bobbins are machined from billet aluminium and they are extremely solid thanks also to the big diameter of the piece. They secure the bikes also during the transportation, avoiding any possible fall from the trestle. For the assembling you only need an Allen key. 5 YEARS WARRANTY.

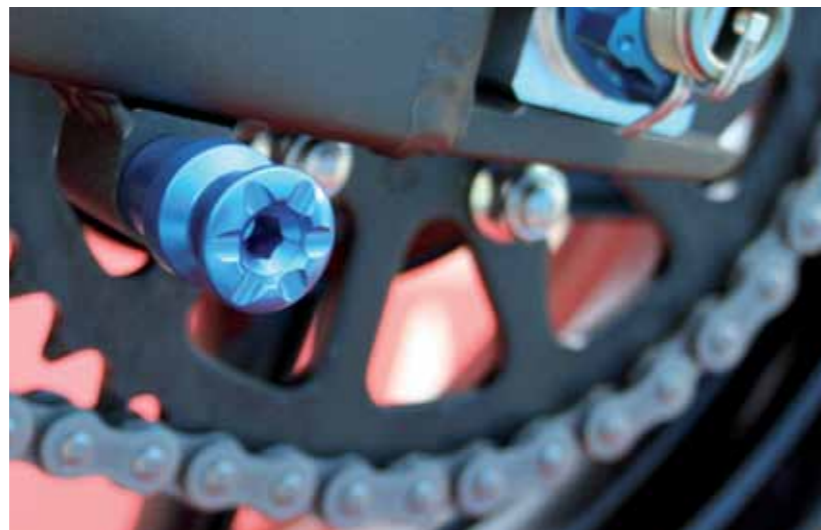

MARKE/BRAND	MODELL/MODEL	JAHR/YEAR	CODE/CODE	FARB/CODE/COLOUR	EURO w/o tax
APRILIA	RSV 1000 R / Factory / RSV4	'05-'10	PS-M6b	Si Dn Ti Rg Cr Eb	15,00
	TUONO 1000 R / Factory	'06-'10	PS-M6b	Si Dn Ti Rg Cr Eb	15,00
	Dorsoduro, Shiver, RS125	'08-'10	PS-M6	Si Dn Ti Rg Cr Eb	15,00
BMW	S1000 RR	'10>	PS-M8b	Si Dn Ti Rg Cr Eb	15,00
DUCATI	749/999 base / S / R	'05-'10	PS-M8	Si Dn Ti Rg Cr Eb	15,00
HONDA	alle anderen Modelle / all other models	/	PS-M8	Si Dn Ti Rg Cr Eb	15,00
	CBR 600 RR	'07-'10	PS-M8b	Si Dn Ti Rg Cr Eb	15,00
KAWASAKI	ZX6 R / RR	'03-'06	PS-M10	Si Dn Ti Rg Cr Eb	15,00
	ZX6R	'07-'10	PS-M10b	Si Dn Ti Rg Cr Eb	15,00
	Z 1000	'03-'06	PS-M10	Si Dn Ti Rg Cr Eb	15,00
	ZX 10R	'04-'05	PS-M10	Si Dn Ti Rg Cr Eb	15,00
	Z 750 / S	'04-'10	PS-M10b	Si Dn Ti Rg Cr Eb	15,00
	ER-6N / F	'06-'10	PS-M10b	Si Dn Ti Rg Cr Eb	15,00
	ZX 10R	'06-'07	PS-M10b	Si Dn Ti Rg Cr Eb	15,00
	ZX 10R	'08-'10	PS-M10	Si Dn Ti Rg Cr Eb	15,00
	Z 1000	'07-'09	PS-M10b	Si Dn Ti Rg Cr Eb	15,00
	Z 1000	'10	PS-M10d	Si Dn Ti Rg Cr Eb	15,00
KTM	VERSYS	'07-'10	PS-M10b	Si Dn Ti Rg Cr Eb	15,00
KTM	filetto / thread M10 x 1,5	/	PS-M10c	Si Dn Or	15,00
SUZUKI	GSX-R 600 / 750	'97-'03	PS-M8	Si Dn Ti Rg Cr Eb	15,00
	GSX-R 1000	'01-'02	PS-M8	Si Dn Ti Rg Cr Eb	15,00
	SV 650 / S	'00-'10	PS-M8	Si Dn Ti Rg Cr Eb	15,00
	GSX-R 600 / 750	'04-'10	PS-M8b	Si Dn Ti Rg Cr Eb	15,00
	GSX-R 1000	'03-'10	PS-M8b	Si Dn Ti Rg Cr Eb	15,00
	SV 1000 / S	'03-'10	PS-M8b	Si Dn Ti Rg Cr Eb	15,00
	GSR 600	'06-'10	PS-M8b	Si Dn Ti Rg Cr Eb	15,00
	HAYABUSA	tutte / all	PS-M8b	Si Dn Ti Rg Cr Eb	15,00
	B-KING	'08-'10	PS-M8b	Si Dn Ti Rg Cr Eb	15,00
	Gladius	/	PS-M8	Si Dn Ti Rg Cr Eb	15,00
YAMAHA	tutte con foro M6 / M6 hole	/	PS-M6	Si Dn Ti Rg Cr Eb	15,00

Wir empfehlen den Einsatz einer geeigneten Schraubensicherung (z.B. Loctite) für die PS-M6 Modelle./ We suggest to apply some thread glue only for the PS-M6 models

KETTENSPANNER AXIAL BLOCKS

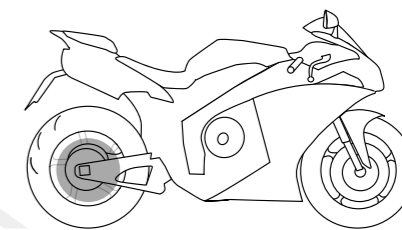

Evotech hat sich entschlossen, eine Reihe hochwertiger und eleganter Anbauteile für KTM-Motorräder zu entwickeln. Der Kettenspanner ersetzt das Original ohne zusätzliche Modifikationen. Die Passung mit der Schwinge wurde verbessert und mehr Markierungen zur besseren Justierung des Hinterrades eingefräst. Das Gewicht wurde deutlich reduziert, und die Stabilität dennoch beibehalten. Eloxiert. 3 verschiedene Farbtöne stehen zur Auswahl.

Evotech has decided to create a set of precious and refined accessories for Ktm bikes. The Chain adjuster replaces the original components without making any modifications. The match with the swingarm has been optimized and there are more dents to allow a faster and more accurate wheel alignment. It has been lightened in many points without precluding the reliability and it is available in 3 wonderful anodized colours.

**5 JAHRE GARANTIE
5 YEARS WARRANTY**



MARKE/BRAND	MODELL/MODEL	CODE/CODE	FARB/CODE/COLOUR	EURO w/o tax
KTM	690 SMC	BT-0900	Si Dn Or	65,00
	990 Supermoto	BT-0900	Si Dn Or	65,00
	950 Supermoto R	BT-0900	Si Dn Or	65,00
	690 Duke	BT-0900	Si Dn Or	65,00
	990 Superduke	BT-0900	Si Dn Or	65,00
	990 Superduke R	BT-0900	Si Dn Or	65,00
	1190 RC8	BT-0900	Si Dn Or	65,00
	690 Supermoto	BT-0900	Si Dn Or	65,00
	690 Supermoto R	BT-0900	Si Dn Or	65,00

MARKE/BRAND	MODELL/MODEL	CODE/CODE	FARB/CODE/COLOUR	EURO w/o tax
KTM	Offroad Competition LX 125/150/250/450	BT-0902	Si Dn Or	65,00
	Offroad Comepetition EXC 125/200/250/300/400/450/530)	BT-0902	Si Dn Or	65,00
	SUPERMOTO 450 SMR	BT-0902	Si Dn Or	65,00
	625 SMC	BT-0902	Si Dn Or	65,00

THUNDERBOLT

ACHSMUTTER-VORDERRAD
FRONT WHEEL NUT

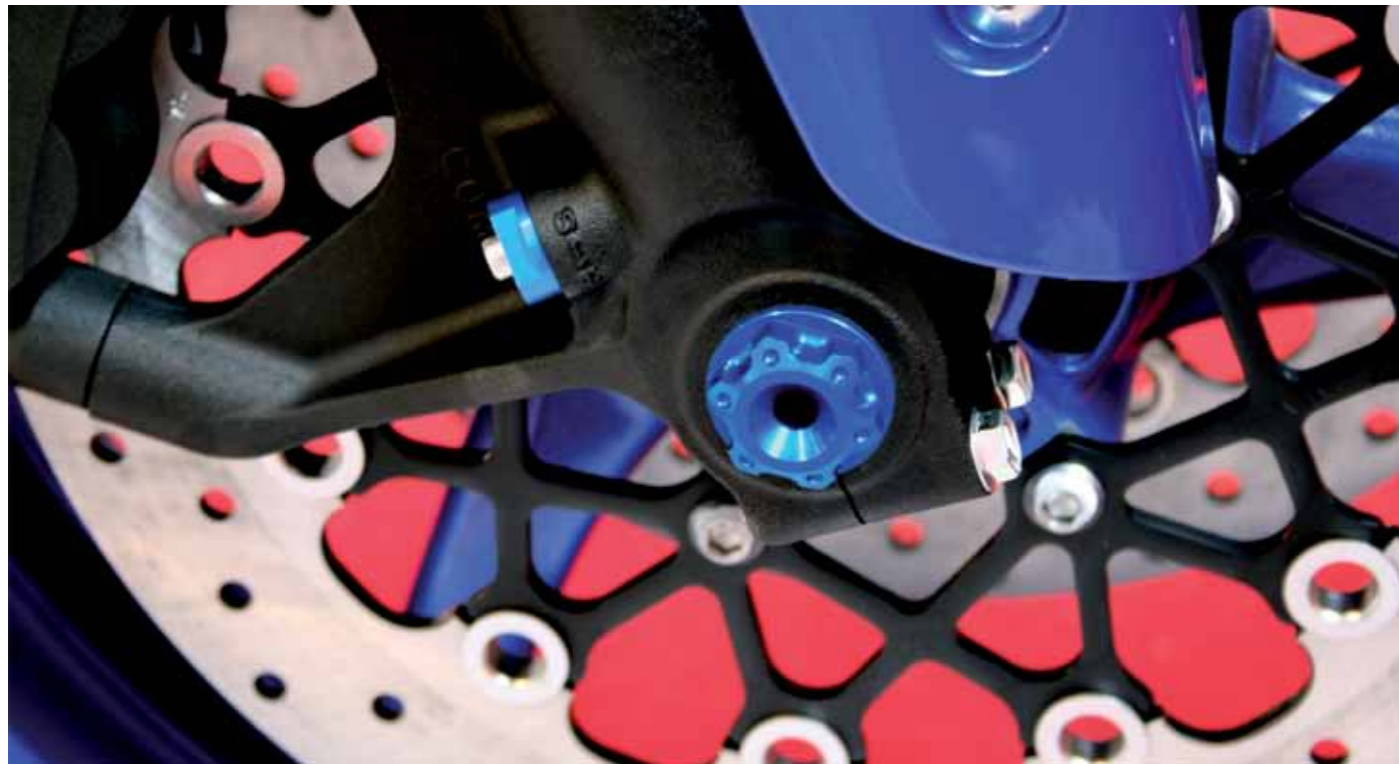
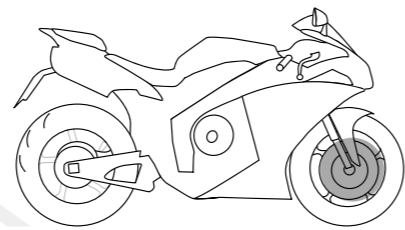

MARKE/BRAND	MODELL/MODEL	JAHR/YEAR	CODE/CODE	FARBCODE/COLOUR	EURO w/o tax
APRILIA	RSV 1000 R/ Factory	'02-'10	TB-018	Si Dn Ti Rg Cr Eb	19,50
	RSV4/TUONO R/ Factory	'02-'10	TB-018	Si Dn Ti Rg Cr Eb	19,50
	Dorsoduro/ Shiver	'08-'10	TB-018	Si Dn Ti Rg Cr Eb	19,50
	RS 125	'08-'10	TB-018	Si Dn Ti Rg Cr Eb	19,50
	HONDA	CBR 600 F/ Sport	'99-'06	TB-060	Si Dn Ti Rg Cr Eb
CBR 600 RR		'03-'10	TB-060	Si Dn Ti Rg Cr Eb	19,50
HORNET 600		'98-'10	TB-060	Si Dn Ti Rg Cr Eb	19,50
HORNET 900		'02-'07	TB-060	Si Dn Ti Rg Cr Eb	19,50
CBR 1000 RR		'04-'10	TB-061	Si Dn Ti Rg Cr Eb	19,50
CBR 929/954 RR		'00-'03	TB-061	Si Dn Ti Rg Cr Eb	19,50
CB 1000 R		'08-'10	TB-060	Si Dn Ti Rg Cr Eb	19,50
VTR SP1/SP2		/	TB-060	Si Dn Ti Rg Cr Eb	19,50
KAWASAKI	ZX 10R	'06-'10	TB-005	Si Dn Ti Rg Cr Eb	19,50
SUZUKI	GSX-R 600/750	'06-'10	TB-061	Si Dn Ti Rg Cr Eb	19,50
	GSX-R 1000	'05-'10	TB-061	Si Dn Ti Rg Cr Eb	19,50
	BANDIT 1200/S	'06-'07	TB-061	Si Dn Ti Rg Cr Eb	19,50
	B-KING	'08-'10	TB-061	Si Dn Ti Rg Cr Eb	19,50
	HAYABUSA	'09>	TB-061	Si Dn Ti Rg Cr Eb	19,50
YAMAHA	R6	'06-'10	TB-060	Si Dn Ti Rg Cr Eb	19,50
	R1	'02-'10	TB-060	Si Dn Ti Rg Cr Eb	19,50

5 JAHRE GARANTIE
5 YEARS WARRANTY

THUNDERBOLT

ACHSMUTTER-HINTERRAD
REAR WHEEL NUT

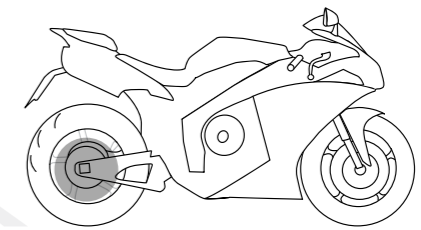

MARKE/BRAND	MODELL/MODEL	JAHR/YEAR	CODE/CODE	FARBCODE/COLOUR	EURO w/o tax
APRILIA	RSV 1000 R/ RSV4	'02-'10	TB-018	Si Dn Ti Rg Cr Eb	19,50
	TUONO R / FACTORY	'02-'10	TB-018	Si Dn Ti Rg Cr Eb	19,50
	RS125	'08-'10	TB-018	Si Dn Ti Rg Cr Eb	19,50
	Dorsoduro/ Shiver	'08-'10	TB-018	Si Dn Ti Rg Cr Eb	19,50
BMW	S1000 RR	'10>	TB-005	Si Dn Ti Rg Cr Eb	19,50
DUCATI	749/999	'02-'06	TB-002	Si Dn Ti Rg Cr Eb	19,50
HONDA	CBR 600 F	'99-'06	TB-001	Si Dn Ti Rg Cr Eb	19,50
	HORNET 600	'98-'06	TB-017	Si Dn Ti Rg Cr Eb	19,50
	HORNET 600	'07-'10	TB-001	Si Dn Ti Rg Cr Eb	19,50
	CBR 600 RR	'03-'10	TB-003	Si Dn Ti Rg Cr Eb	19,50
	CBR 929/954 RR	'00-'03	TB-003	Si Dn Ti Rg Cr Eb	19,50
	CBR 1000 RR	'04-'10	TB-003	Si Dn Ti Rg Cr Eb	19,50
	HORNET 900	'02-'07	TB-001	Si Dn Ti Rg Cr Eb	19,50
	VTR SP1- SP2	/	TB-003	Si Dn Ti Rg Cr Eb	19,50
KAWASAKI	ZX6R/ RR	'03-'10	TB-005	Si Dn Ti Rg Cr Eb	19,50
	ZX10R	'04-'10	TB-001	Si Dn Ti Rg Cr Eb	19,50
	Z1000	'03-'09	TB-005	Si Dn Ti Rg Cr Eb	19,50
	Z750/S	'04-'10	TB-001	Si Dn Ti Rg Cr Eb	19,50
	ER6-N/F - VERSYS	'06-'10	TB-001	Si Dn Ti Rg Cr Eb	19,50
	SUZUKI	GSX-R 600/750/1000	'00-'10	TB-008	Si Dn Ti Rg Cr Eb
SV650/S		'00-'10	TB-001	Si Dn Ti Rg Cr Eb	19,50
GSR 600		'06-'10	TB-003	Si Dn Ti Rg Cr Eb	19,50
Bandit 1200/S		'05-'08	TB-008	Si Dn Ti Rg Cr Eb	19,50
SV 1000/S		'04-'10	TB-008	Si Dn Ti Rg Cr Eb	19,50
Hayabusa		'99-'10	TB-008	Si Dn Ti Rg Cr Eb	19,50
B-King		'08-'10	TB-008	Si Dn Ti Rg Cr Eb	19,50
Gladius		/	TB-002	Si Dn Ti Rg Cr Eb	19,50
TRIUMPH	Daytona 675 Triple	'06-'10	TB-001	Si Dn Ti Rg Cr Eb	19,50
	Street Triple	'07-'10	TB-001	Si Dn Ti Rg Cr Eb	19,50
YAMAHA	R6	'99-'10	TB-005	Si Dn Ti Rg Cr Eb	19,50
	R1	'98-'08	TB-005	Si Dn Ti Rg Cr Eb	19,50
	R1	'09-'10	TB-015	Si Dn Ti Rg Cr Eb	19,50
	Fazer 600	'98-'03	TB-001	Si Dn Ti Rg Cr Eb	19,50
	Fazer 1000	'01-'05	TB-005	Si Dn Ti Rg Cr Eb	19,50
	FZ6 / Fazer/S2	'04-'10	TB-005	Si Dn Ti Rg Cr Eb	19,50
	FZ1 / Fazer/ FZ8	'06-'10	TB-005	Si Dn Ti Rg Cr Eb	19,50
	MT-01	'05-'06	TB-005	Si Dn Ti Rg Cr Eb	19,50
	XJ6	'09 >	TB-017	Si Dn Ti Rg Cr Eb	19,50

THUNDERBOLT

ACHSMUTTER-SCHWINGE
SWINGARM NUT

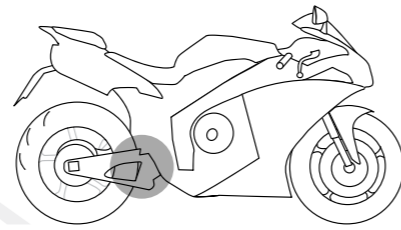

MARKE/BRAND	MODELL/MODEL	JAHR/YEAR	CODE/CODE	FARB/CODE/COLOUR	EURO w/o tax
APRILIA	Rsv 1000 / Tuono / RSV4	tutte/all	TB-002	Si Dn Ti Rg Cr Eb	19,50
	Dorsoduro / Shiver	'08-'10	TB-002	Si Dn Ti Rg Cr Eb	19,50
BMW	S1000 RR	'10>	TB-001	Si Dn Ti Rg Cr Eb	19,50
HONDA	CBR 600 F / Sport	'99-'06	TB-001	Si Dn Ti Rg Cr Eb	19,50
	CBR 600 RR	'07-'10	TB-001	Si Dn Ti Rg Cr Eb	19,50
	HORNET 600	'98-'06	TB-016	Si Dn Ti Rg Cr Eb	19,50
	HORNET 600	'07-'10	TB-001	Si Dn Ti Rg Cr Eb	19,50
	CBR 1000 RR	'04-'10	TB-003	Si Dn Ti Rg Cr Eb	19,50
	CB 1000 R	'08-'10	TB-001	Si Dn Ti Rg Cr Eb	19,50
	VTR SP1	/	TB-003	Si Dn Ti Rg Cr Eb	19,50
VTR SP2	/	TB-001	Si Dn Ti Rg Cr Eb	19,50	
KAWASAKI	ZX6R / RR	'03-'10	TB-002	Si Dn Ti Rg Cr Eb	19,50
	ZX10R	'04-'10	TB-002	Si Dn Ti Rg Cr Eb	19,50
	Z1000	'10	TB-002	Si Dn Ti Rg Cr Eb	19,50
SUZUKI	GSX-R 600 / 750	'00-'03	TB-008	Si Dn Ti Rg Cr Eb	19,50
	GSX-R 600 / 750	'04-'10	TB-002	Si Dn Ti Rg Cr Eb	19,50
	GSX-R 1000	'01-'04	TB-008	Si Dn Ti Rg Cr Eb	19,50
	GSX-R 1000	'05-'10	TB-002	Si Dn Ti Rg Cr Eb	19,50
	SV 650 / S	'00-'10	TB-001	Si Dn Ti Rg Cr Eb	19,50
	SV 1000 / S	'04-'10	TB-008	Si Dn Ti Rg Cr Eb	19,50
	Hayabusa	'99-'10	TB-008	Si Dn Ti Rg Cr Eb	19,50
B-king	'08-'10	TB-002	Si Dn Ti Rg Cr Eb	19,50	
TRIUMPH	DAYTONA 675 Triple	'06-'10	TB-017	Si Dn Ti Rg Cr Eb	19,50
	Street Triple 675	'07-'10	TB-017	Si Dn Ti Rg Cr Eb	19,50
YAMAHA	R6	'99-'05	TB-001	Si Dn Ti Rg Cr Eb	19,50
	R6 links Mutter / Left nut	'06-'10	TB-003	Si Dn Ti Rg Cr Eb	19,50
	R6 rechte Ringmutter / Right ring	'06-'10	TB-011	Si Dn Ti Rg Cr Eb	19,50
	R1	'98-'06	TB-001	Si Dn Ti Rg Cr Eb	19,50
	R1 links Mutter / Left nut	'07-'10	TB-002	Si Dn Ti Rg Cr Eb	19,50
	R1 rechte Ringmutter / Right ring	'07-'10	TB-020	Si Dn Ti Rg Cr Eb	19,50
	Fazer 600	'98-'03	TB-001	Si Dn Ti Rg Cr Eb	19,50
	FZ6 / Faze/S2	'04-'10	TB-001	Si Dn Ti Rg Cr Eb	19,50
	FZ1 / Fazer/FZ8	'06-'10	TB-001	Si Dn Ti Rg Cr Eb	19,50
	MT-03	'06-'10	TB-017	Si Dn Ti Rg Cr Eb	19,50

THUNDERBOLT

GABELBRÜCKENMUTTER
TOP YOKE NUT

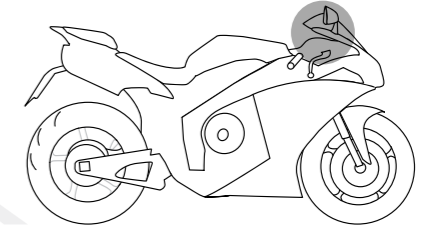

Sehr hochwertige Duraluminium Muttern (7075T6). Durch die Bearbeitung an CNC- gesteuerten Maschinen ist ein tolles Design und ein raffinierter Look realisierbar. Die 6 Ausbuchtungen und die 6 frontalen Bohrungen reduzieren Gewicht, im Vergleich zum Original, ohne dass die Stabilität darunter leidet. Das Anzugsmoment bleibt unverändert. Die Montage erfolgt mit handelsüblichem Ringschlüssel. Eloxiert. 6 verschiedene Farbtöne stehen zur Auswahl.

Ergal nuts machined from ergal 7075-T6 bars through sophisticated numerical control machineries. The amazing design gives a refined look to your special bike. The six pockets and the six frontal holes realized on the nut give it less weight compared to the original component. These lightening don't preclude the resistance of the product and in fact the chiselling has not been realized on the key torque point. The assembly is very easy: through a simple hexagonal key. Available in 6 anodized colours.



5 JAHRE GARANTIE
5 YEARS WARRANTY

MARKE / BRAND	MODELL / MODEL	JAHR / YEAR	CODE / CODE	FARB / CODE / COLOUR	EURO w/o tax
APRILIA	Dorsoduro / Shiver	'08-'09	TB-010	Si Dn Ti Rg Cr Eb	19,50
BMW	S1000 RR	'10>	TB-009	Si Dn Ti Rg Cr Eb	19,50
HONDA	CBR 600 F	'99-'06	TB-004	Si Dn Ti Rg Cr Eb	19,50
	CBR 600 RR	'03-'10	TB-004	Si Dn Ti Rg Cr Eb	19,50
	CBR 900 RR	'00-'03	TB-004	Si Dn Ti Rg Cr Eb	19,50
	HORNET 600	'98-'10	TB-004	Si Dn Ti Rg Cr Eb	19,50
	HORNET 900	'02-'07	TB-004	Si Dn Ti Rg Cr Eb	19,50
	VTR SP1	/	TB-004	Si Dn Ti Rg Cr Eb	19,50
	CBR1000RR	'08-'10	TB-019	Si Dn Ti Rg Cr Eb	19,50
KAWASAKI	ZX 6R / RR	'05-'10	TB-009	Si Dn Ti Rg Cr Eb	19,50
	ZX10R	'04-'07	TB-009	Si Dn Ti Rg Cr Eb	19,50
SUZUKI	GSX-R 600 / 750	'00-'05	TB-015	Si Dn Ti Rg Cr Eb	19,50
	GSX-R 600 / 750	'06-'10	TB-009	Si Dn Ti Rg Cr Eb	19,50
	GSX-R 1000	'00-'02	TB-015	Si Dn Ti Rg Cr Eb	19,50
	GSX-R 1000	'03-'10	TB-009	Si Dn Ti Rg Cr Eb	19,50
	SV650 / S	'00-'02	TB-010	Si Dn Ti Rg Cr Eb	19,50
	SV 650 / S	'03-'10	TB-015	Si Dn Ti Rg Cr Eb	19,50
	SV 1000 / S	'04-'10	TB-015	Si Dn Ti Rg Cr Eb	19,50
	Hayabusa	tutte / all	TB-015	Si Dn Ti Rg Cr Eb	19,50
	GSR 600 Naked	'06-'10	TB-015	Si Dn Ti Rg Cr Eb	19,50
	BANDIT 650 / S	'06-'10	TB-015	Si Dn Ti Rg Cr Eb	19,50
	B-King	'08-'10	TB-015	Si Dn Ti Rg Cr Eb	19,50
YAMAHA	R6	'99-'10	TB-009	Si Dn Ti Rg Cr Eb	19,50
	R1	'98-'10	TB-009	Si Dn Ti Rg Cr Eb	19,50
	Fazer 600	'98-'03	TB-010	Si Dn Ti Rg Cr Eb	19,50
	Fazer 1000	'01-'05	TB-010	Si Dn Ti Rg Cr Eb	19,50
	FZ6 / Fazer	'04-'10	TB-010	Si Dn Ti Rg Cr Eb	19,50
	FZ1 N / Fazer / FZ8	'06-'10	TB-009	Si Dn Ti Rg Cr Eb	19,50
	MT-03	'06-'10	TB-010	Si Dn Ti Rg Cr Eb	19,50
	XJ6	'09>	TB-010	Si Dn Ti Rg Cr Eb	19,50

ACHSABDECKUNGEN FÜR TMAX WHEEL PIN COVER TMAX

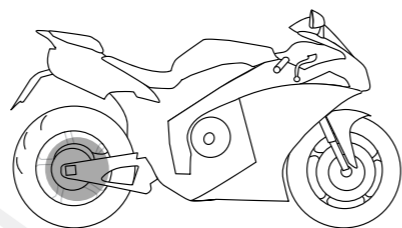

Dieses wunderschöne Zubehör zeigt wiederum das elegant-sportliche Evotech-Design. Wir stellen diese Achsabdeckung in 4 verschiedenen Farbtönen bereit (blau, rot, gold und schwarz). Die Abdeckung ist mit Laser graviert.

This amazing accessory shows again the elegant and dynamic Evotech style. We realized these items for Tmax scooter in four brilliant colours: blue, red, gold and black. The pin has been screen printed by laser.

**5 JAHRE GARANTIE
5 YEARS WARRANTY**



MARKE / BRAND	MODELL / MODEL	JAHR / YEAR	CODE / CODE	FARBCODE / COLOUR	EURO w/o tax
YAMAHA	T-MAX	'01-'07	CPR-TM1	Dn Rg Cr Eb	60,00
		'08-'10	CPR-TM2	Dn Rg Cr Eb	105,00

ÖL-EINFÜLLSCHRAUBEN OIL FILLER CAP

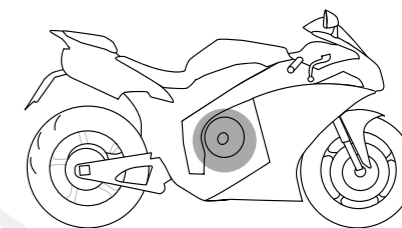

Evotech Öl-Einfüllschrauben sind aus dem Vollen gefräst. Durch die Bearbeitung an CNC-gesteuerten Maschinen ist ein sehr schönes Design realisierbar. Das besondere Material wird die Verschraubung stabil und fest. Der spezielle Sechskant reduziert die Gefahr des Diebstahls. Es wird ein spezieller Schlüssel benötigt. Spezielle Bohrungen ermöglichen den Einsatz eines Sicherheitsdrahtes. Die 6 Ausbuchtungen und die 6 frontalen Bohrungen reduzieren Gewicht, im Vergleich zum Original, ohne dass die Stabilität darunter leidet. Eloxiert. 6 verschiedene Farbtöne stehen zur Auswahl. 5 Jahre Garantie

Evotech oil filler caps are machined from billet aluminium through sophisticated CNC machineries. The incredible design gives to specials a refined style and material makes our caps very safe and strong. We realized these accessories with an hexagonal head in order to avoid that someone can steal your oil cap. Some holes have been made around its shape for fixing the safety wire which is binding during competitions. The 6 milled pockets and the 6 holes give to our oil caps lightness but without precluding its resistance. Oil filler caps are available in 6 wonderful brilliant colours. 5 YEARS WARRANTY



MARKE / BRAND	PASSO / THREAD	FARBCODE / COLOUR	CODE / CODE	EURO w/o tax
APRILIA	M20 x 1,5	Si Dn Ti Rg Cr Eb	OFC-01	17,90
	Dorsoduro / Shiver / RSV4	Si Dn Ti Rg Cr Eb	OFC-06	17,90
BMW	S1000 RR	Si Dn Ti Rg Cr Eb	OFC-11	17,90
BENELLI	M24 x 1,5	Si Dn Ti Rg Cr Eb	OFC-02	17,90
DUCATI	M22 x 1,5	Si Dn Ti Rg Cr Eb	OFC-03	17,90
	848*	Si Dn Ti Rg Cr Eb	OFC-04	17,90
	Monster 696* Monster 1100	Si Dn Ti Rg Cr Eb	OFC-04 OFC-03	17,90 17,90
HONDA	M20 x 2,5	Si Dn Ti Rg Cr Eb	OFC-04	17,90
KAWASAKI	M30 x 1,5	Si Dn Ti Rg Cr Eb	OFC-05	17,90
	ER6-N / F / Versys	Si Dn Ti Rg Cr Eb	OFC-04	17,90
	Z1000 '10 >	Si Dn Ti Rg Cr Eb	OFC-04	17,90
	KLV KX 125 '00-'08	Si Dn Ti Rg Cr Eb	OFC-01 OFC-04	17,90 17,90
KTM	M24X3	Si Dn Or	OFC-09	17,90
MV AGUSTA	M25 x 1,5	Si Dn Ti Rg Cr Eb	OFC-06	17,90
SUZUKI	M20 x 1,5	Si Dn Ti Rg Cr Eb	OFC-01	17,90
TRIUMPH	M20 X 2,5	Si Dn Ti Rg Cr Eb	OFC-08	17,90
YAMAHA	M26 x 3	Si Dn Ti Rg Cr Eb	OFC-07	17,90
	T-MAX M20 x 2,5	Si Dn Ti Rg Cr Eb	OFC-04	17,90
	WR 125 / 250 '00-'08	Si Dn Ti Rg Cr Eb	OFC-04	17,90
	WRF 250 / 450 '00-'08	Si Dn Ti Rg Cr Eb	OFC-04	17,90
	YZ 125 / 250 '00-'08	Si Dn Ti Rg Cr Eb	OFC-04	17,90
	YZF 250 / 450 '00-'08	Si Dn Ti Rg Cr Eb	OFC-04	17,90

*Kupplung im Ölbad / clutch in oil bath

BREMSFLÜSSIGKEITSBEHÄLTER REAR BRAKE/CLUTCH FLUID TANK

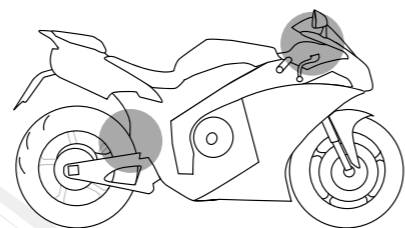

Evotech bietet verschiedene Flüssigkeitsbehälter für DOT-4 Flüssigkeit, die für die hydraulische Kupplung und als Bremsflüssigkeitsbehälter für die hintere Bremse dienen. Diese Behälter sind sowohl für den Rennsport und bei Anpassung auf Ihr Motorrad für den Strassenbetrieb geeignet. Sie ersetzen den Originalbehälter. Diese Behälter haben ein Entlüftungssystem, das durch eine Membran die korrekte Funktion ermöglicht, auch dann, wenn der Füllstand sinkt.

- Der Kit enthält:
- Säurebeständiges eloxiertes Aluminiumbehälter
 - Spezielle Halterung in eloxiertem Aluminium
 - Deckel in eloxiertem Aluminium
 - Membran-Dichtung
 - Haltering die Dichtung
 - Düsenrohrhalter aus eloxiertem Aluminium
- Durch die Kombination der Farben der drei Hauptkomponenten, können Sie bis zu 216 Farbkombinationen erreichen

Evotech's now offers the finest designs to replace your rear brake and hydraulic clutch reservoirs. DOT 4 compatible

Our superior designs are suitable both for racing use and for the customization of your machine. The reservoirs are easy to replace on all hydraulic fluid systems

The reservoirs have been designed with a unique vent system that allows the membrane to adapt itself to the tank and to the decrease of hydraulic fluid during use.

- The kit includes:
- Aircraft grade anodized aluminum body tank
 - Aircraft grade anodized aluminum bracket
 - Aircraft grade anodized aluminum cap
 - Membrane gasket
 - Retaining ring for the gasket
 - Aircraft grade tube fitting in anodized aluminum

By combining the colors of the three main components, you can get up to 216 combinations for the ultimate in customization.



CODE/CODE	MODELL/MODEL	FARBCODE/COLOUR	EURO w/o tax
RT-01-A	Kupplung/hintere Bremse-rear brake/clutch	Si Dn Ti Rg Cr Eb /	35,00
RT-01-C		Si Dn Ti Rg Cr Eb Or	
RTB-UP1		Si Dn Ti Rg Cr Eb /	

Zur Bestellung des Kits RT-01 müssen nachfolgende Teile separat angegeben werden:
To order the kit RT-01 the following codes must be specified separately:

- RT-01-A/RG
- RT-01-C/DN
- RTB-UP1/RG

Wenn Sie die Farbtöne nicht angeben, dann werden beide Komponenten gleichfarbig ausgeliefert
If you do not specify the color of all components it will be considered as monochrome



BREMSFLÜSSIGKEITSBEHÄLTER FRONT BRAKE FLUID TANK

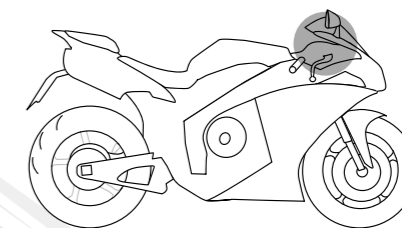

Der neue Evotech-Behälter für Hydraulikflüssigkeit, ist sowohl für den Einsatz im Rennsport als auch für den Strassenbetrieb ausgelegt. Er verleiht Ihrem Motorrad Rennsport-Stil. Geeignet als Bremsflüssigkeitsbehälter der Vorderradbremse. 36 verschiedene Farbkombinationen möglich. Elegante Form und Liebe zum Detail, spiegelt sich in diesem Behälter wider.

Diese Behälter haben ein Entlüftungssystem, das durch eine Membran die korrekte Funktion ermöglicht, auch dann, wenn der Füllstand sinkt.

- Das Kit enthält:
- Eloxiertes Aluminiumgehäuse
 - Deckel in eloxiertem Aluminium
 - Düsenrohrhalter aus eloxiertem Aluminium
 - Membrane
 - Bullauge zur Füllstandskontrolle
 - Weichgummi
 - Spezial-Schraube Ergal zur Befestigung
 - angepasster Befestigungsbügel aus gebürstetem Edelstahl

The new Evotech front brake reservoir (DOT 3 and DOT 4 compatible) has been designed both for racing use and/or to give a touch of beautiful Italian style to your motorcycle. Can be matched in 36 different color combinations by choosing cap and body colors.

Elegant and unique in its shape, Evotech reservoirs are a distinctive component compared to standard tanks. All are equipped with a unique vent circuit able to control the liquid level during consumption.

- The kit includes:
- Aircraft grade anodized aluminum body
 - Aircraft grade anodized aluminum cap
 - Aircraft grade tube fitting in black anodized aluminum
 - Membrane
 - Window for liquid control level
 - Elastic rubber
 - Special Ergal screw for the mounting bracket
 - Mounting bracket in brushed stainless steel



CODE/CODE	MODELL/MODEL	FARBCODE/COLOUR	EURO w/o tax
RT-05-A	Front Bremse-Front brake	Si Dn Ti Rg Cr Eb /	55,00
RT-05-C		Si Dn Ti Rg Cr Eb Or	

Zur Bestellung des Kits RT-05 müssen nachfolgende Teile separat angegeben werden:
To order the kit RT-05 the following codes must be specified separately:

- RT-05-C/SI
- RT-05-A/EB

Wenn Sie die Farbtöne nicht angeben, dann werden beide Komponenten gleichfarbig ausgeliefert
If you do not specify the color of both components it will be considered as monochrome



SCHNELLWECHSEL-TANKDECKEL RAPID GAS CAP

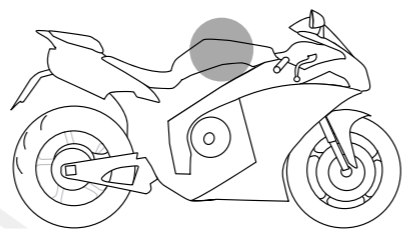

Dank der Schnellwechsel-Tankdeckel von Evotech war das Betanken noch nie so schnell und einfach. Mit einer Drehung des Hebels um 35° gegen den Uhrzeigersinn lässt sich der Tankdeckel öffnen. Perfekt für die Strasse und den Renneinsatz. In unserem System ist ein gleichwertiger Entlüftungsmechanismus verbaut, wie beim Original. Der ungewollte Austritt von Benzin wird somit vermieden.

Thanks to the opening system of new Evotech rapid gas cap, refuelling has never been so fast and easy. Push the central lever and turn it counter-clockwise for about 35 degree. Rapid gas cap is perfect for street or racing use. The cap maintains the same fuel venting system as the original cap, avoiding any loss of fuel.

**5 JAHRE GARANTIE
5 YEARS WARRANTY**



MARKE/BRAND	MODELL/MODEL	CODE/CODE	FARBCODE/COLOUR	EURO w/o tax
APRILIA	RSV4 FACTORY/R '09>	FCR-A2	Si Dn Ti Rg Cr Eb /	120,00
	RSV 1000 R/Factory '04>	FCR-A2	Si Dn Ti Rg Cr Eb /	120,00
	Tuono 1000 R/Factory '06>	FCR-A2	Si Dn Ti Rg Cr Eb /	120,00
BMW	S1000RR	FCR-BMW	Si Dn Ti Rg Cr Eb /	120,00
DUCATI	MONSTER 696/1100 '09	FCR-DU2	Si Dn Ti Rg Cr Eb /	120,00
	Streetfighter '09	FCR-A2	Si Dn Ti Rg Cr Eb /	120,00
	Monster 600/750/900/620/695/1000	FCR-DMY	Si Dn Ti Rg Cr Eb /	120,00
	800/S2R/S4/S4R/1098/1198/848	FCR-DMY	Si Dn Ti Rg Cr Eb /	120,00
	916/996/998/748	FCR-DMY	Si Dn Ti Rg Cr Eb /	120,00
HONDA	alle/all	FCR-HO	Si Dn Ti Rg Cr Eb /	120,00
KAWASAKI	Z750 '07-'10	FCR-KA2	Si Dn Ti Rg Cr Eb /	120,00
	Z1000 '07-'09	FCR-KA2	Si Dn Ti Rg Cr Eb /	120,00
	ZX6R/ZX10R/ZX14R	FCR-KA2	Si Dn Ti Rg Cr Eb /	120,00
	ER6N/F '09>	FCR-KA2	Si Dn Ti Rg Cr Eb /	120,00
	ZZR 1400	FCR-KA2	Si Dn Ti Rg Cr Eb /	120,00
	VERSYS '07-'09	FCR-KA2	Si Dn Ti Rg Cr Eb /	120,00
MV AGUSTA	5 viti/5 bolts	FCR-DMY	Si Dn Ti Rg Cr Eb /	120,00
	Brutale '10	FCR-A2	Si Dn Ti Rg Cr Eb /	120,00
KTM	RC8	FCR-A2	Si Dn Ti Rg Cr Eb /	120,00
SUZUKI	Bandit GSF 1200/1250/650/S	FCR-SU2	Si Dn Ti Rg Cr Eb /	120,00
	Gladius	FCR-SU2	Si Dn Ti Rg Cr Eb /	120,00
	GSR 600	FCR-SU2	Si Dn Ti Rg Cr Eb /	120,00
	GSX-F 650 '08-'10	FCR-SU2	Si Dn Ti Rg Cr Eb /	120,00
	GSX-R 1000 '03-'10	FCR-SU2	Si Dn Ti Rg Cr Eb /	120,00
	GSX-R 1300 '08-	FCR-SU2	Si Dn Ti Rg Cr Eb /	120,00
	GSX-R 600/750 '04-'10	FCR-SU2	Si Dn Ti Rg Cr Eb /	120,00
	SV650/SV1000	FCR-SU2	Si Dn Ti Rg Cr Eb /	120,00
YAMAHA		FCR-DMY	Si Dn Ti Rg Cr Eb /	120,00
	Universeller Innendeckel/universal inner cap	FCR-U2	Si Dn Ti Rg Cr Eb Or	/

TANKDECKEL FUEL CAP

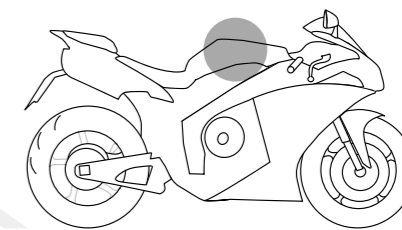

Wieder hat Evotech ein besonderes und exklusives Zubehör für Ihr Motorrad entwickelt. Technische Details:

- ein neuartiges Evotech-Labyrinth verhindert den Austritt von Kraftstoff.
- der grössere Durchmesser der Einfüllöffnung gegenüber dem Original-Tankdeckel ermöglicht schnelleres und einfacheres Tanken.
- Diese Teile sind aus speziellem Aluminium aus der Luftfahrt gefertigt.
- In 6 verschiedenen Farbtönen erhältlich.

Sie können durch die Farbwahl des Innen- und Aussendeckels 36 verschiedene Farbkombinationen wählen. Durch die Farbwahl der Duraluminium-Schrauben sind dann 180 Farbkombinationen möglich. Der Aussenring ist speziell für das entsprechende Motorrad konzipiert. Ein O-Ring verhindert das Austreten von Benzin und verhindert eine ungewollte Druckänderung im Tank.

Once again Evotech has created a special and exclusive accessory for your bike. Technical details:

- a new and Evotech exclusive labyrinth for fuel venting
- the diameter of fuel opening is larger than OEM for quicker refueling on the track.
- the parts are CNC machined from aluminium billet
- fuel caps are available in six different colours.

You can "mix and match" the two parts (inner cap and outer mounting part) and 36 different combinations can be created. In addition you can fit also our ergal bolts kit on the tank cap getting 180 different colour combinations. The outer ring that fits on the tank has been designed to comply to the different model bikes for easy installation. We also decided to put a gasket between the two parts in order to avoid any loss of fuel and to maintain the correct pressure.



MARKE/BRAND	MODELL/MODEL	CODE/CODE	FARBCODE/COLOUR	EURO w/o tax
APRILIA	SHIVER 750	FC-ATB	Si Dn Ti Rg Cr Eb	80,00
	RS125 '06>	FC-ATB	Si Dn Ti Rg Cr Eb	80,00
	RS250 '98>	FC-ATB	Si Dn Ti Rg Cr Eb	80,00
	Tuono 1000 <'05	FC-ATB	Si Dn Ti Rg Cr Eb	80,00
	RSV 1000 <'03	FC-ATB	Si Dn Ti Rg Cr Eb	80,00
	RSV 1000 '04-'08	FC-A2	Si Dn Ti Rg Cr Eb	80,00
	TUONO '05-'09	FC-A2	Si Dn Ti Rg Cr Eb	80,00
	RSV4 /R/FACTORY	FC-A2	Si Dn Ti Rg Cr Eb	80,00
BENELLI	TNT 899/1130	FC-ATB	Si Dn Ti Rg Cr Eb	80,00
DUCATI	748/916/996/998	FC-DU	Si Dn Ti Rg Cr Eb	80,00
	SS 620/800/900	FC-DU	Si Dn Ti Rg Cr Eb	80,00
	PAUL SMART 1000	FC-DU	Si Dn Ti Rg Cr Eb	80,00
	GT 1000 '07>	FC-DU	Si Dn Ti Rg Cr Eb	80,00
	848/1098/1198	FC-DU	Si Dn Ti Rg Cr Eb	80,00
	888 SP5	FC-DU	Si Dn Ti Rg Cr Eb	80,00
	STREETFIGHTER	FC-A2	Si Dn Ti Rg Cr Eb	80,00
HONDA	von /from 2000	FC-HO	Si Dn Ti Rg Cr Eb	80,00

TANKDECKEL FUEL CAP

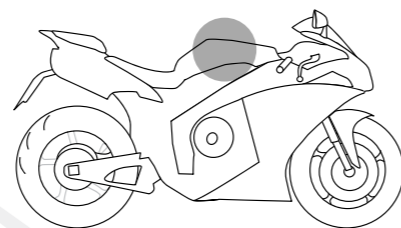

MARKE/BRAND	MODELL/MODEL	CODE/CODE	FARB/CODE/COLOUR						EURO w/o tax
KAWASAKI	Z750 '04-'06	FC-KA1	Si	Dn	Ti	Rg	Cr	Eb	80,00
	Z1000 '03-'06	FC-KA1	Si	Dn	Ti	Rg	Cr	Eb	80,00
	ZX6R/RR '03-'06	FC-KA1	Si	Dn	Ti	Rg	Cr	Eb	80,00
	ZX10R '04-'05	FC-KA1	Si	Dn	Ti	Rg	Cr	Eb	80,00
	ZX9R '00-'04	FC-KA1	Si	Dn	Ti	Rg	Cr	Eb	80,00
	ER6N/F '06-'08	FC-KA1	Si	Dn	Ti	Rg	Cr	Eb	80,00
	Z750 '07-'10	FC-KA2	Si	Dn	Ti	Rg	Cr	Eb	80,00
	Z1000 '07-'10	FC-KA2	Si	Dn	Ti	Rg	Cr	Eb	80,00
	ZX6R '07-'10	FC-KA2	Si	Dn	Ti	Rg	Cr	Eb	80,00
	ZX10R '06-'10	FC-KA2	Si	Dn	Ti	Rg	Cr	Eb	80,00
	ER6N/F '09-'10	FC-KA2	Si	Dn	Ti	Rg	Cr	Eb	80,00
	ZZR 1400	FC-KA2	Si	Dn	Ti	Rg	Cr	Eb	80,00
	VERSYS '07-'09	FC-KA2	Si	Dn	Ti	Rg	Cr	Eb	80,00
	ZX14R	FC-KA2	Si	Dn	Ti	Rg	Cr	Eb	80,00
ZX250 '09>	FC-KA3	Si	Dn	Ti	Rg	Cr	Eb	80,00	
KTM	990 SUPERDUKE	FC-ATB	Si	Dn	Ti	Rg	Cr	Eb	80,00
	950 ADVENTURE	FC-ATB	Si	Dn	Ti	Rg	Cr	Eb	80,00
	990 ADVENTURE	FC-ATB	Si	Dn	Ti	Rg	Cr	Eb	80,00
	RC8	FC-A2	Si	Dn	Ti	Rg	Cr	Eb	80,00
MV AGUSTA	Brutale '10	FC-A2	Si	Dn	Ti	Rg	Cr	Eb	80,00
SUZUKI	7 viti / 7 bolts								
	Bandit GSF 1200	FC-SU1	Si	Dn	Ti	Rg	Cr	Eb	80,00
	Bandit GSF 600/S	FC-SU1	Si	Dn	Ti	Rg	Cr	Eb	80,00
	DL 1000 V-Strom	FC-SU1	Si	Dn	Ti	Rg	Cr	Eb	80,00
	DL 650 V-Strom	FC-SU1	Si	Dn	Ti	Rg	Cr	Eb	80,00
	GS 500 '01-	FC-SU1	Si	Dn	Ti	Rg	Cr	Eb	80,00
	GSX 1400	FC-SU1	Si	Dn	Ti	Rg	Cr	Eb	80,00
	GSX 750 F '98-	FC-SU1	Si	Dn	Ti	Rg	Cr	Eb	80,00
	GSX 750 Naked	FC-SU1	Si	Dn	Ti	Rg	Cr	Eb	80,00
	GSX F 600 '97-'00	FC-SU1	Si	Dn	Ti	Rg	Cr	Eb	80,00
	GSX-F 750 F '98>	FC-SU1	Si	Dn	Ti	Rg	Cr	Eb	80,00
	GSX R 1000 '01-'02	FC-SU1	Si	Dn	Ti	Rg	Cr	Eb	80,00
	GSX R 1100 '91-'97	FC-SU1	Si	Dn	Ti	Rg	Cr	Eb	80,00
	GSX R 1300 Hayabusa-'07	FC-SU1	Si	Dn	Ti	Rg	Cr	Eb	80,00
	GSX R 600 '97-'03	FC-SU1	Si	Dn	Ti	Rg	Cr	Eb	80,00
	GSX R 750 '92-'03	FC-SU1	Si	Dn	Ti	Rg	Cr	Eb	80,00
	RF 600	FC-SU1	Si	Dn	Ti	Rg	Cr	Eb	80,00
	RF 900 '94-'97	FC-SU1	Si	Dn	Ti	Rg	Cr	Eb	80,00
	SV 650/S -'02	FC-SU1	Si	Dn	Ti	Rg	Cr	Eb	80,00
	TL 1000 R/S	FC-SU1	Si	Dn	Ti	Rg	Cr	Eb	80,00
	XF 650 Freewind	FC-SU1	Si	Dn	Ti	Rg	Cr	Eb	80,00
	5 viti / 5 bolts								
	Bandit GSF 1200/1250	FC-SU2	Si	Dn	Ti	Rg	Cr	Eb	80,00
	Bandit GSF 650/S '05-'07	FC-SU2	Si	Dn	Ti	Rg	Cr	Eb	80,00
Gladius	FC-SU2	Si	Dn	Ti	Rg	Cr	Eb	80,00	
GSR 600	FC-SU2	Si	Dn	Ti	Rg	Cr	Eb	80,00	
GSX F 650'08-'10	FC-SU2	Si	Dn	Ti	Rg	Cr	Eb	80,00	
GSX R 1000 '03-'10	FC-SU2	Si	Dn	Ti	Rg	Cr	Eb	80,00	

TANKDECKEL FUEL CAP

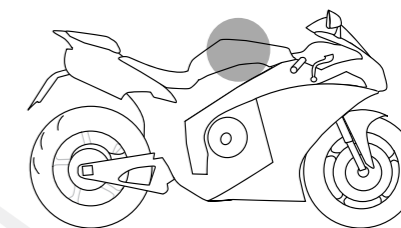

MARKE/BRAND	MODELL/MODEL	CODE/CODE	FARB/CODE/COLOUR						EURO w/o tax
SUZUKI	GSX R 1300 '08-'10	FC-SU2	Si	Dn	Ti	Rg	Cr	Eb	80,00
	GSX R 600/750 '04-'10	FC-SU2	Si	Dn	Ti	Rg	Cr	Eb	80,00
	SV 1000	FC-SU2	Si	Dn	Ti	Rg	Cr	Eb	80,00
	SV 650/S	FC-SU2	Si	Dn	Ti	Rg	Cr	Eb	80,00
TRIUMPH	SPEED TRIPLE 1050	FC-ATB	Si	Dn	Ti	Rg	Cr	Eb	80,00
	DAYTONA 955i	FC-ATB	Si	Dn	Ti	Rg	Cr	Eb	80,00
	DAYTONA T955 '02-'04	FC-ATB	Si	Dn	Ti	Rg	Cr	Eb	80,00
	SPEED TRIPLE T955 '02-'04	FC-ATB	Si	Dn	Ti	Rg	Cr	Eb	80,00
YAMAHA	Fazer 600 -'03	FC-YA	Si	Dn	Ti	Rg	Cr	Eb	80,00
	FZ6/FZ6 S2	FC-YA	Si	Dn	Ti	Rg	Cr	Eb	80,00
	MT-03	FC-YA	Si	Dn	Ti	Rg	Cr	Eb	80,00
	Thundercat 600	FC-YA	Si	Dn	Ti	Rg	Cr	Eb	80,00
	R6 '99-'10	FC-YA	Si	Dn	Ti	Rg	Cr	Eb	80,00
	YZF 750 '93-'98	FC-YA	Si	Dn	Ti	Rg	Cr	Eb	80,00
	Thunderace 1000	FC-YA	Si	Dn	Ti	Rg	Cr	Eb	80,00
	R1 '00-'10	FC-YA	Si	Dn	Ti	Rg	Cr	Eb	80,00
	FZ1/Fazer 1000 -'05-'10	FC-YA	Si	Dn	Ti	Rg	Cr	Eb	80,00
	FZ1 Naked '06-'10	FC-YA	Si	Dn	Ti	Rg	Cr	Eb	80,00
	Bulldog	FC-YA	Si	Dn	Ti	Rg	Cr	Eb	80,00
	MT-01	FC-YA	Si	Dn	Ti	Rg	Cr	Eb	80,00
	TDM 850 '91-'01	FC-YA	Si	Dn	Ti	Rg	Cr	Eb	80,00
	TDM 900	FC-YA	Si	Dn	Ti	Rg	Cr	Eb	80,00
	XJR 1300	FC-YA	Si	Dn	Ti	Rg	Cr	Eb	80,00
	Universeller Innendeckel / universal inner cap		FC-U	Si	Dn	Ti	Rg	Cr	Eb

**5 JAHRE GARANTIE
5 YEARS WARRANTY**

SCHRAUBENSÄTZE FÜR TANKDECKEL FUEL CAP BOLTS KIT

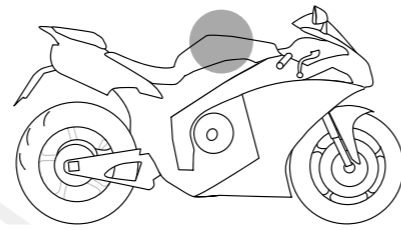

MARKE/BRAND	MODELL/MODEL	JAHR/YEAR	CODE/CODE	FARBCODE/COLOUR	EURO w/o tax
APRILIA	RS 125	'97-'00	KVS-003	Sf Dn Rg Cr Eb	9,40
	RS 250 Replica	'99>	KVS-005	Sf Dn Rg Cr Eb	7,70
	SL FALCO 1000		KVS-005	Sf Dn Rg Cr Eb	7,70
	TUONO	'02-'05	KVS-004	Sf Dn Rg Cr Eb	7,95
	TUONO	'06-'09	KVS-004	Sf Dn Rg Cr Eb	7,95
	RSV 1000/R/Factory	98-'09	KVS-004	Sf Dn Rg Cr Eb	7,95
	SHIVER 750	07-'10	KVS-004	Sf Dn Rg Cr Eb	7,95
BENELLI	TnT 1130/899	/	KVS-004	Sf Dn Rg Cr Eb	7,95
	TRE 1130 K	/	KVS-004	Sf Dn Rg Cr Eb	7,95
BMW	F 650 Enduro	'93-'99	KVS-007	Sf Dn Rg Cr Eb	8,40
	R 1100 RT	'95-'00	KVS-007	Sf Dn Rg Cr Eb	8,40
	R 1150 RT	'01-'05	KVS-007	Sf Dn Rg Cr Eb	8,40
	R 1150 GS/Adventure	'99>	KVS-007	Sf Dn Rg Cr Eb	8,40
	R 1200 CL	'02>	KVS-007	Sf Dn Rg Cr Eb	8,40
	R 1100 RS	'98-'03	KVS-007	Sf Dn Rg Cr Eb	8,40
	K 1200 RS	'97-'00	KVS-007	Sf Dn Rg Cr Eb	8,40
	K 1200 RS	'01-'05	KVS-007	Sf Dn Rg Cr Eb	8,40
	K 1200 R	'05>	KVS-007	Sf Dn Rg Cr Eb	8,40
	K 1200 GT	'06>	KVS-007	Sf Dn Rg Cr Eb	8,40
DUCATI	748/916/996/749/999	/	KVS-012	Sf Dn Rg Cr Eb	6,50
	MONSTER DS 1000	'03-'09	KVS-012	Sf Dn Rg Cr Eb	6,50
	848/1098/1198	/	KVS-012	Sf Dn Rg Cr Eb	6,50
	MONSTER 696/1100	'08-'09	KVS-040	Sf Dn Rg Cr Eb	14,30
	ST2/ST4	/	KVS-013	Sf Dn Rg Cr Eb	9,90
HONDA	CBR 600	<'00	KVS-014	Sf Dn Rg Cr Eb	8,50
	CBR 600 F/Sport	'01-'02	KVS-015	Sf Dn Rg Cr Eb	8,50
	CBR 900 RR	'96-'99	KVS-014	Sf Dn Rg Cr Eb	8,50
	VFR 750	'90-'97	KVS-014	Sf Dn Rg Cr Eb	8,50
	VFR 800	'98>	KVS-014	Sf Dn Rg Cr Eb	8,50
	VTR 1000 F	/	KVS-014	Sf Dn Rg Cr Eb	8,50
	X 11	/	KVS-014	Sf Dn Rg Cr Eb	8,50
	CBR 1100 XX	/	KVS-014	Sf Dn Rg Cr Eb	8,50
	CB 1300	/	KVS-015	Sf Dn Rg Cr Eb	8,50
	VTR SP1	'00-'01	KVS-014	Sf Dn Rg Cr Eb	8,50
	VTR SP2	<'02	KVS-015	Sf Dn Rg Cr Eb	8,50
	CBR 600 RR	'03-'10	KVS-015	Sf Dn Rg Cr Eb	8,50
	HORNET 600	'03-'10	KVS-015	Sf Dn Rg Cr Eb	8,50
	HORNET 900	'03-'07	KVS-015	Sf Dn Rg Cr Eb	8,50
	CB 1000 R	'08-'10	KVS-015	Sf Dn Rg Cr Eb	8,50
	CBR 929 RR	'00-'01	KVS-014	Sf Dn Rg Cr Eb	8,50
CBR 954 RR	'02-'03	KVS-015	Sf Dn Rg Cr Eb	8,50	
CBR 1000 RR	'04-'10	KVS-015	Sf Dn Rg Cr Eb	8,50	
MV AGUSTA	F4 750/1000	5 viti/5 bolts	KVS-012	Sf Dn Rg Cr Eb	6,50
	BRUTALE	5 viti/5 bolts	KVS-012	Sf Dn Rg Cr Eb	6,50
KAWASAKI	ZX250 Ninja	'08-'10	KVS-027	Sf Dn Rg Cr Eb	7,20
	ZX6R	'00-'02	KVS-041	Sf Dn Rg Cr Eb	6,00
	ZX6R/RR	'03-'06	KVS-041	Sf Dn Rg Cr Eb	6,00
	ZX6R	'07-'10	KVS-017	Sf Dn Rg Cr Eb	6,00

SCHRAUBENSÄTZE FÜR TANKDECKEL FUEL CAP BOLTS KIT

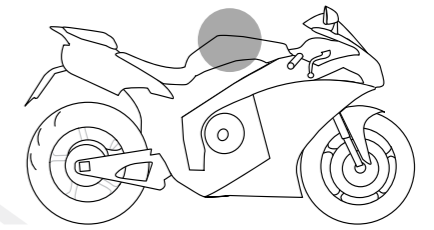

MARKE/BRAND	MODELL/MODEL	JAHR/YEAR	CODE/CODE	FARBCODE/COLOUR	EURO w/o tax
KAWASAKI	ER6-N/F	'06-'10	KVS-017	Sf Dn Rg Cr Eb	5,90
	VERSYS	'07-'10	KVS-017	Sf Dn Rg Cr Eb	5,90
	ZX7R	/	KVS-019	Sf Dn Rg Cr Eb	8,19
	ZX9R	'98-'99	KVS-019	Sf Dn Rg Cr Eb	8,19
	ZX9R	'00-'04	KVS-041	Sf Dn Rg Cr Eb	6,00
	ZX10R	'04-'10	KVS-017	Sf Dn Rg Cr Eb	5,90
	Z 750	'04-'10	KVS-017	Sf Dn Rg Cr Eb	5,90
	Z 1000	'03-'09	KVS-017	Sf Dn Rg Cr Eb	5,90
	ZX12R	/	KVS-018	Sf Dn Rg Cr Eb	4,70
	SUZUKI	SV 650/S	'03-'09	KVS-026	Sf Dn Rg Cr Eb
SV 1000/S		'03-'09	KVS-026	Sf Dn Rg Cr Eb	6,17
FREEWIND 650		/	KVS-023	Sf Dn Rg Cr Eb	8,97
GSR 600		'06-'10	KVS-026	Sf Dn Rg Cr Eb	6,17
GSX-R 600		'97-'03	KVS-022	Sf Dn Rg Cr Eb	8,67
GSX-R 750		'00-'03	KVS-022	Sf Dn Rg Cr Eb	8,67
GSX-R 600/750		'04-'10	KVS-026	Sf Dn Rg Cr Eb	6,17
GSX-R 1000		'01-'02	KVS-022	Sf Dn Rg Cr Eb	8,67
GSX-R 1000		'03-'04	KVS-026	Sf Dn Rg Cr Eb	6,17
GSX-R 1000		'05-'10	KVS-026	Sf Dn Rg Cr Eb	6,17
GSF 1200 Bandit		/	KVS-028	Sf Dn Rg Cr Eb	9,80
GSX-R 1300 Hayabusa		'99-'07	KVS-022	Sf Dn Rg Cr Eb	8,67
GSX-R 1300 Hayabusa		'08-'10	KVS-026	Sf Dn Rg Cr Eb	6,17
KTM	Superduke 990	'05-'09	KVS-020	Sf Dn Rg Cr Eb	7,65
TRIUMPH	TT 600	/	KVS-029	Sf Dn Rg Cr Eb	7,80
	SPRINT	/	KVS-029	Sf Dn Rg Cr Eb	7,80
	SPEED TRIPLE	'97-'10	KVS-029	Sf Dn Rg Cr Eb	7,80
	DAYTONA 675	'06-'10	KVS-029	Sf Dn Rg Cr Eb	7,80
	STREET TRIPLE	'07-'10	KVS-009	Sf Dn Rg Cr Eb	8,10
	DAYTONA 955 i	'02-'05	KVS-009	Sf Dn Rg Cr Eb	8,10
YAMAHA	FZR 400/600	/	KVS-033	Sf Dn Rg Cr Eb	10,41
	Fazer 600	'97-'03	KVS-024	Sf Dn Rg Cr Eb	8,50
	Fazer 1000	'99-'05	KVS-024	Sf Dn Rg Cr Eb	8,50
	FZ6/Fazer/S2	'04-'10	KVS-036	Sf Dn Rg Cr Eb	6,10
	R6	'99-'02	KVS-012	Sf Dn Rg Cr Eb	6,50
	R6	'05-'10	KVS-042	Sf Dn Rg Cr Eb	6,20
	MT-03	'06-'10	KVS-042	Sf Dn Rg Cr Eb	6,40
	XJ6	'09-'10	KVS-042	Sf Dn Rg Cr Eb	6,40
	TDM 850	'91-'95	KVS-034	Sf Dn Rg Cr Eb	8,58
	TDM 850	'96-'01	KVS-035	Sf Dn Rg Cr Eb	8,50
	TDM 900	'02-'10	KVS-024	Sf Dn Rg Cr Eb	8,50
	R1	'98-'01	KVS-024	Sf Dn Rg Cr Eb	8,50
	R1	'02-'03	KVS-036	Sf Dn Rg Cr Eb	6,10
	R1	'04-'10	KVS-042	Sf Dn Rg Cr Eb	6,20
FZ1 Naked/Fazer	'06-'10	KVS-042	Sf Dn Rg Cr Eb	6,20	
BT Bulldog 1100	'02-'06	KVS-010	Sf Dn Rg Cr Eb	7,94	
XVS 1100 Dragstar	'99-'02	KVS-037	Sf Dn Rg Cr Eb	3,51	

5 JAHRE GARANTIE
5 YEARS WARRANTY

SCHRAUBENSÄTZE FÜR VERKLEIDUNGSSCHEIBEN SCREEN BOLTS KIT

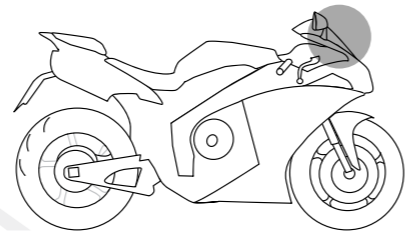

MARKE/BRAND	MODELL/MODEL	JAHR/YEAR	CODE/CODE	FARB/CODE/COLOUR	EURO w/o tax
APRILIA	RS 125	'06-'10	KVC-032	Si Dn Rg Cr Eb	16,60
	RS 250	'99-	KVC-030	Si Dn Rg Cr Eb	7,00
	TUONO	'03-'05	KVC-001	Si Dn Rg Cr Eb	14,20
	RSV 1000	'01-'03	KVC-002	Si Dn Rg Cr Eb	13,60
	RSV 1000/R/Factory	'04-'05	KVC-003	Si Dn Rg Cr Eb	12,40
	SHIVER 750	'07-'10	KVC-029	Si Dn Rg Cr Eb	6,80
	RSV4	/	KVC-020	Si Dn Rg Cr Eb	6,40
BMW	S1000RR	'10	KVC-034	Si Dn Rg Cr Eb	13,20
DUCATI	748/916/996/749/999	/	KVC-004	Si Dn Rg Cr Eb	14,40
	MONSTER S4	'01-'02	KVC-005	Si Dn Rg Cr Eb	6,90
	MONSTER DS 1000	'03-	KVC-006	Si Dn Rg Cr Eb	21,10
	998	/	KVC-018	Si Dn Rg Cr Eb	18,30
HONDA	CBR 600 RR	'03-'06	KVC-008	Si Dn Rg Cr Eb	9,90
	CBR 600 RR	'07-	KVC-015	Si Dn Rg Cr Eb	13,30
	CBR 900 RR	'97-'99	KVC-008	Si Dn Rg Cr Eb	9,90
	CBR 600 F/S	'01-'06	KVC-008	Si Dn Rg Cr Eb	9,90
	VTR SP1/SP2	'00-'03	KVC-008	Si Dn Rg Cr Eb	9,90
	CBR 929 RR	'00-'01	KVC-009	Si Dn Rg Cr Eb	9,90
	CBR 954 RR	'02-'03	KVC-010	Si Dn Rg Cr Eb	21,45
	CBR 1000 RR	'04-'07	KVC-008	Si Dn Rg Cr Eb	9,90
	CBR 1000 RR	'08-'10	KVC-016	Si Dn Rg Cr Eb	6,60
MV AGUSTA	F4 750 / 1000	/	KVC-013	Si Dn Rg Cr Eb	16,50
KAWASAKI	ZX6R	'00-'02	KVC-008	Si Dn Rg Cr Eb	9,90
	ZX6R/RR	'03-'04	KVC-015	Si Dn Rg Cr Eb	13,30
	ZX6R	'05-'08	KVC-008	Si Dn Rg Cr Eb	9,90
	ZX6R	'09-'10	KVC-023	Si Dn Rg Cr Eb	15,50
	ZX9R	'00-'03	KVC-008	Si Dn Rg Cr Eb	9,90

SCHRAUBENSÄTZE FÜR VERKLEIDUNGSSCHEIBEN SCREEN BOLTS KIT

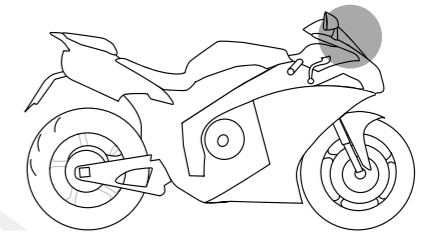

MARKE/BRAND	MODELL/MODEL	JAHR/YEAR	CODE/CODE	FARB/CODE/COLOUR	EURO w/o tax
KAWASAKI	ZX10R	'04-'10	KVC-008	Si Dn Rg Cr Eb	9,90
	ZX12R	'00-	KVC-008	Si Dn Rg Cr Eb	9,90
	Z 1000	'03-'06	KVC-016	Si Dn Rg Cr Eb	6,60
KTM	SUPER DUKE 990	'07-'10	KVC-016	Si Dn Rg Cr Eb	6,60
	990 SUPERMOTO T		KVC-033	Si Dn Rg Cr Eb	16,60
SUZUKI	GSX-R 600 / 750	'04-'05	KVC-016	Si Dn Rg Cr Eb	6,60
	GSX-R 600 / 750	'06-'10	KVC-024	Si Dn Rg Cr Eb	10,00
	GSX-R 1000	'05-'10	KVC-008	Si Dn Rg Cr Eb	9,90
YAMAHA	Fazer 600	'99-'03	KVC-026	Si Dn Rg Cr Eb	13,60
	FZ6 Fazer	'04-	KVC-025	Si Dn Rg Cr Eb	10,70
	Fazer 1000	'99-'05	KVC-026	Si Dn Rg Cr Eb	13,60
	XJ6	'09-'10	KVC-030	Si Dn Rg Cr Eb	7,00
	R6	'99-'00	KVC-016	Si Dn Rg Cr Eb	6,60
	R6	'03-'10	KVC-016	Si Dn Rg Cr Eb	6,60
	R1	'98-'06	KVC-008	Si Dn Rg Cr Eb	9,90
	FZ1 Naked	'06-'10	KVC-031	Si Dn Rg Cr Eb	9,20

5 JAHRE GARANTIE
5 YEARS WARRANTY

SCHRAUBENSÄTZE ERGAŁ BOLTS

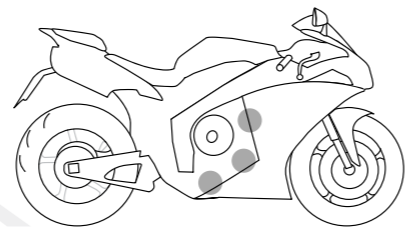

Evotech Schrauben sind in Duraluminium aus dem Vollen gefräst. Durch die Bearbeitung an CNC gesteuerten Maschinen ist ein sehr schönes Design realisierbar. Eine Gewichtsreduzierung auf 60% gegenüber Stahlschrauben ist möglich. Das besondere Material wird die Verschraubung stabil und fest. Eloxiert. 6 verschiedene Farbtöne stehen zur Auswahl. Duraluminium Schrauben sind passend für unkritische Bereiche, die die Fahrsicherheit nicht direkt beeinträchtigen.

Anwendungsbeispiele: Schutzbleche, Nummernschildhalter, Verkleidungsscheiben, Verkleidungen, Randabdeckungen, Abdeckungen, Tankdeckel, Auspuffblenden, Fersenschützer, Kupplungshebel, Krümmerschrauben usw

Machined from Ergal 7075 T6 bars through CNC machineries. Thanks to material and machining technologies these bolts weight less than 60% compared to the steel bolts. They are available in 5 anodized colours. Ergal is suitable to use in ALL NON-SAFETY CRITICAL AREAS e.g. mudguards, screens, fairings, engine casings, huggers, fuel caps, fuel cap surround, number plates, lamp units, exhaust cans, heel plates, clutch levers, exhaust manifold brackets and so on.

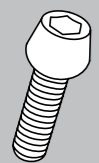

TCCE



CODE/CODE	MODELL/MODEL	FARB/CODE/COLOUR	EURO w/o tax
TCCE	M5X10	Si Dn Rg Cr Eb	1,15
TCCE	M5X15	Si Dn Rg Cr Eb	1,20
TCCE	M5X20	Si Dn Rg Cr Eb	1,30
TCCE	M5X25	Si Dn Rg Cr Eb	1,40
TCCE	M5X30	Si Dn Rg Cr Eb	1,45
TCCE	M5X35	Si Dn Rg Cr Eb	1,50
TCCE	M6X10	Si Dn Rg Cr Eb	1,15
TCCE	M6X15	Si Dn Rg Cr Eb	1,20
TCCE	M6X20	Si Dn Rg Cr Eb	1,30
TCCE	M6X25	Si Dn Rg Cr Eb	1,40
TCCE	M6X30	Si Dn Rg Cr Eb	1,45
TCCE	M6X35	Si Dn Rg Cr Eb	1,50
TCCE	M6X40	Si Dn Rg Cr Eb	1,55
TCCE	M6X45	Si Dn Rg Cr Eb	1,65
TCCE	M6X50	Si Dn Rg Cr Eb	1,70
TCCE	M6X55	Si Dn Rg Cr Eb	1,85
TCCE	M6X60	Si Dn Rg Cr Eb	1,95
TCCE	M6X65	Si Dn Rg Cr Eb	2,05
TCCE	M6X70	Si Dn Rg Cr Eb	2,15
TCCE	M6X75	Si Dn Rg Cr Eb	2,30
TCCE	M6X80	Si Dn Rg Cr Eb	2,35
TCCE	M6X85	Si Dn Rg Cr Eb	2,40
TCCE	M6X90	Si Dn Rg Cr Eb	2,50
TCCE	M6X95	Si Dn Rg Cr Eb	2,70
TCCE	M6X100	Si Dn Rg Cr Eb	2,80
TCCE	M8X10	Si Dn Rg Cr Eb	1,40
TCCE	M8X15	Si Dn Rg Cr Eb	1,50
TCCE	M8X20	Si Dn Rg Cr Eb	1,55
TCCE	M8X25	Si Dn Rg Cr Eb	1,65
TCCE	M8X30	Si Dn Rg Cr Eb	1,70
TCCE	M8X35	Si Dn Rg Cr Eb	1,80
TCCE	M8X40	Si Dn Rg Cr Eb	1,85
TCCE	M8X45	Si Dn Rg Cr Eb	1,90
TCCE	M8X50	Si Dn Rg Cr Eb	2,00
TCCE	M8X55	Si Dn Rg Cr Eb	2,10
TCCE	M8X60	Si Dn Rg Cr Eb	2,20

SCHRAUBENSÄTZE ERGAŁ BOLTS

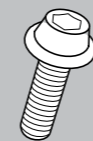
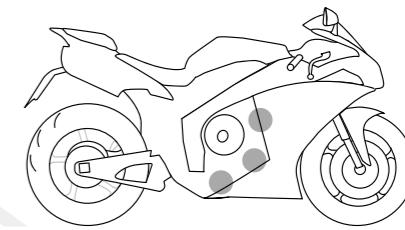

TCRCE

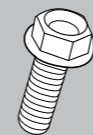

TER

CODE/CODE	MODELL/MODEL	FARB/CODE/COLOUR	EURO w/o tax
TCRCE	M6X10	Si Dn Rg Cr Eb	1,30
TCRCE	M6X15	Si Dn Rg Cr Eb	1,35
TCRCE	M6X20	Si Dn Rg Cr Eb	1,40
TCRCE	M6X25	Si Dn Rg Cr Eb	1,50
TCRCE	M6X30	Si Dn Rg Cr Eb	1,60
TCRCE	M6X35	Si Dn Rg Cr Eb	1,65
TCRCE	M6X40	Si Dn Rg Cr Eb	1,70
TCRCE	M8X35	Si Dn Rg Cr Eb	2,50
TCRCE	M8X40	Si Dn Rg Cr Eb	2,60
TCRCE	M8X45	Si Dn Rg Cr Eb	2,70
TCRCE	M8X50	Si Dn Rg Cr Eb	2,80
TCRCE	M8X55	Si Dn Rg Cr Eb	3,00
TER	M5X10	Si Dn Rg Cr Eb	1,60
TER	M5X15	Si Dn Rg Cr Eb	1,65
TER	M5X20	Si Dn Rg Cr Eb	1,70
TER	M5X25	Si Dn Rg Cr Eb	1,75
TER	M5X30	Si Dn Rg Cr Eb	1,80
TER	M5X35	Si Dn Rg Cr Eb	1,90
TER	M6X10	Si Dn Rg Cr Eb	1,75
TER	M6X15	Si Dn Rg Cr Eb	1,80
TER	M6X20	Si Dn Rg Cr Eb	1,90
TER	M6X25	Si Dn Rg Cr Eb	1,95
TER	M6X30	Si Dn Rg Cr Eb	2,00
TER	M6X35	Si Dn Rg Cr Eb	2,05
TER	M6X40	Si Dn Rg Cr Eb	2,15
TER	M6X45	Si Dn Rg Cr Eb	2,30
TER	M6X50	Si Dn Rg Cr Eb	2,35
TER	M6X55	Si Dn Rg Cr Eb	2,50
TER	M6X60	Si Dn Rg Cr Eb	2,60
TER	M6X65	Si Dn Rg Cr Eb	2,70
TER	M6X70	Si Dn Rg Cr Eb	2,80
TER	M6X75	Si Dn Rg Cr Eb	2,90
TER	M6X80	Si Dn Rg Cr Eb	3,00
TER	M6X85	Si Dn Rg Cr Eb	3,10
TER	M6X90	Si Dn Rg Cr Eb	3,20
TER	M6X95	Si Dn Rg Cr Eb	3,30
TER	M6X100	Si Dn Rg Cr Eb	3,50

SCHRAUBENSÄTZE ERGA BOLTS

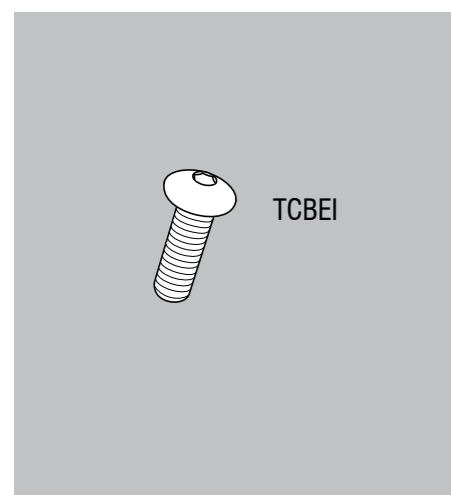
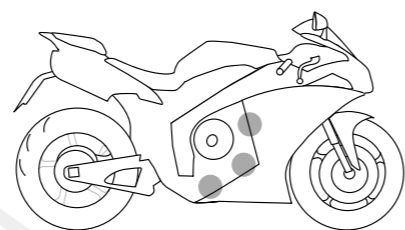

CODE/CODE	MODELL/MODEL	FARB/CODE/COLOUR	EURO w/o tax
TCBEI	M4X10	Dn Si Rg Cr Eb	1,55
TCBEI	M4X15	Dn Si Rg Cr Eb	1,65
TCBEI	M5X10	Dn Si Rg Cr Eb	1,55
TCBEI	M5X15	Dn Si Rg Cr Eb	1,65
TCBEI	M5X20	Dn Si Rg Cr Eb	1,70
TCBEI	M5X25	Dn Si Rg Cr Eb	1,80
TCBEI	M5X30	Dn Si Rg Cr Eb	1,90
TCBEI	M5X35	Dn Si Rg Cr Eb	2,00
TCBEI	M6X10	Dn Si Rg Cr Eb	1,70
TCBEI	M6X15	Dn Si Rg Cr Eb	1,75
TCBEI	M6X20	Dn Si Rg Cr Eb	1,80
TCBEI	M6X25	Dn Si Rg Cr Eb	1,85
TCBEI	M6X30	Dn Si Rg Cr Eb	1,90
TCBEI	M6X35	Dn Si Rg Cr Eb	2,00
TCBEI	M6X40	Dn Si Rg Cr Eb	2,10
TCBEI	M6X45	Dn Si Rg Cr Eb	2,40

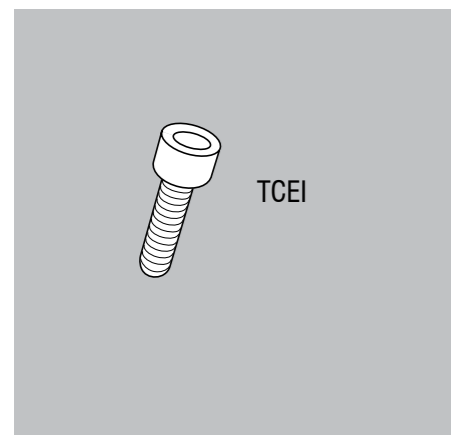

TCEI	M5X8	Dn Si Rg Cr Eb	1,10
TCEI	M5X10	Dn Si Rg Cr Eb	1,15
TCEI	M5X12	Dn Si Rg Cr Eb	1,17
TCEI	M5X15	Dn Si Rg Cr Eb	1,20
TCEI	M5X20	Dn Si Rg Cr Eb	1,30
TCEI	M5X25	Dn Si Rg Cr Eb	1,40
TCEI	M5X30	Dn Si Rg Cr Eb	1,45
TCEI	M6X8	Dn Si Rg Cr Eb	1,10
TCEI	M6X10	Dn Si Rg Cr Eb	1,15
TCEI	M6X12	Dn Si Rg Cr Eb	1,17
TCEI	M6X15	Dn Si Rg Cr Eb	1,20
TCEI	M6X20	Dn Si Rg Cr Eb	1,30
TCEI	M6X25	Dn Si Rg Cr Eb	1,40
TCEI	M6X30	Dn Si Rg Cr Eb	1,45
TCEI	M6X35	Dn Si Rg Cr Eb	1,50

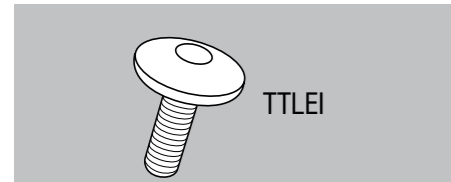

TTLEI	M5X10	Dn Si Rg Cr Eb	1,55
TTLEI	M5X15	Dn Si Rg Cr Eb	1,65
TTLEI	M5X20	Dn Si Rg Cr Eb	1,70
TTLEI	M6X10	Dn Si Rg Cr Eb	1,80
TTLEI	M6X15	Dn Si Rg Cr Eb	1,85

SCHRAUBENSÄTZE ERGA BOLTS

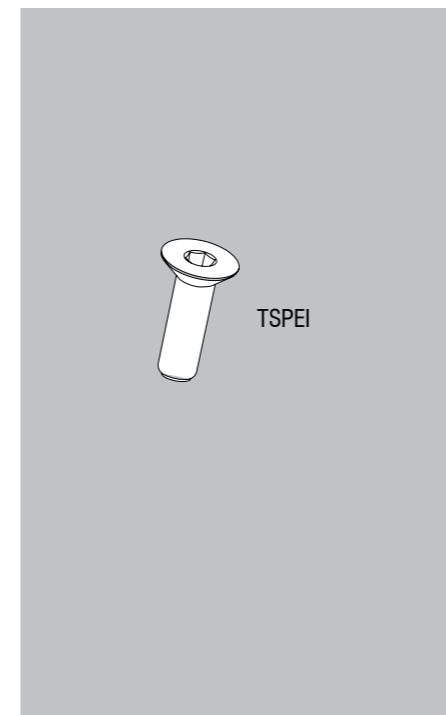
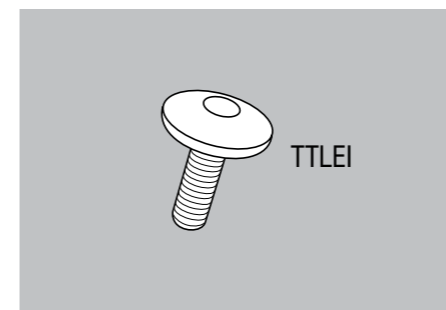
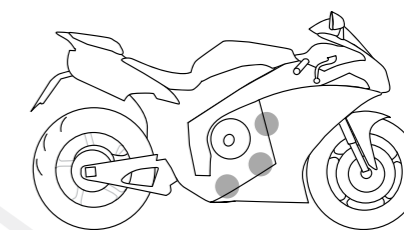

CODE/CODE	MODELL/MODEL	FARB/CODE/COLOUR	EURO w/o tax
TTLEI	M6X20	Dn Si Rg Cr Eb	1,95
TTLEI	M6X25	Dn Si Rg Cr Eb	2,05
TTLEI	M8X15	Dn Si Rg Cr Eb	2,10
TTLEI	M8X20	Dn Si Rg Cr Eb	2,20
TTLEI	M8X25	Dn Si Rg Cr Eb	2,30
TTLEI	M8X30	Dn Si Rg Cr Eb	2,40
TTLEI	M8X35	Dn Si Rg Cr Eb	2,50
TTLEI	M8X40	Dn Si Rg Cr Eb	2,60
TTLEI	M8X45	Dn Si Rg Cr Eb	2,70
TTLEI	M8X50	Dn Si Rg Cr Eb	2,80
TSPEI	M4X10	Dn Si Rg Cr Eb	1,10
TSPEI	M4X15	Dn Si Rg Cr Eb	1,20
TSPEI	M4X20	Dn Si Rg Cr Eb	1,30
TSPEI	M5X10	Dn Si Rg Cr Eb	1,10
TSPEI	M5X15	Dn Si Rg Cr Eb	1,20
TSPEI	M5X20	Dn Si Rg Cr Eb	1,30
TSPEI	M5X25	Dn Si Rg Cr Eb	1,40
TSPEI	M5X30	Dn Si Rg Cr Eb	1,50
TSPEI	M5X35	Dn Si Rg Cr Eb	1,60
TSPEI	M5X40	Dn Si Rg Cr Eb	1,70
TSPEI	M6X10	Dn Si Rg Cr Eb	1,15
TSPEI	M6X15	Dn Si Rg Cr Eb	1,20
TSPEI	M6X20	Dn Si Rg Cr Eb	1,30
TSPEI	M6X25	Dn Si Rg Cr Eb	1,40
TSPEI	M6X30	Dn Si Rg Cr Eb	1,50
TSPEI	M6X35	Dn Si Rg Cr Eb	1,60
TSPEI	M6X40	Dn Si Rg Cr Eb	1,70
TSPEI	M6X45	Dn Si Rg Cr Eb	1,80
TSPEI	M6X50	Dn Si Rg Cr Eb	1,90
TSPEI	M6X55	Dn Si Rg Cr Eb	2,00
TSPEI	M6X60	Dn Si Rg Cr Eb	2,10
TSPEI	M6X65	Dn Si Rg Cr Eb	2,20
TSPEI	M6X70	Dn Si Rg Cr Eb	2,30

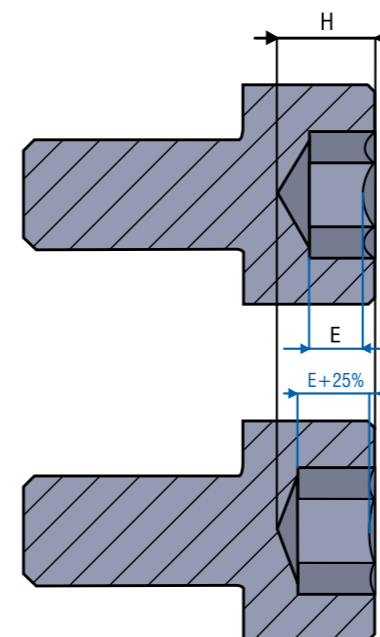

SCHRAUBEN DER WETTBEWERBER/
COMPETITORS BOLT

EVOTECH SCHRAUBEN/ EVOTECH BOLT
25% Tieferer Innensechskant
Hexagonal hole increased of 25%

5 JAHRE GARANTIE
5 YEARS WARRANTY

SCHRAUBENSÄTZE ERGAL BOLTS SPEZIALSCHRAUBEN / SPECIAL BOLTS

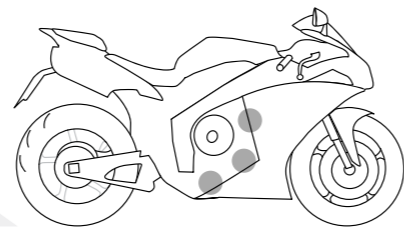

CODE/CODE	M	LG	DC	LC	DT	FARB/CODE/COLOUR	EURO w/o tax
VS-001	M5	16,5	8,1	5,9	14	Dn Sf Rg Cr Eb	2,30
VS-002	M5	12,5	8,1	2,8	14	Dn Sf Rg Cr Eb	2,30
VS-003	M6	20	8,55	10	18	Dn Sf Rg Cr Eb	2,90
VS-004	M6	12,5	8,2	2,8	14	Dn Sf Rg Cr Eb	2,30
VS-005	M6	16,5	8,15	4,9	14	Dn Sf Rg Cr Eb	2,30
VS-006	M5	11,6	8	2,6	14	Dn Sf Rg Cr Eb	2,30
VS-007	M5	12	7	2	14	Dn Sf Rg Cr Eb	2,30
VS-008	M5	10	7	2	14	Dn Sf Rg Cr Eb	2,20
VS-009	M4	12	/	/	9	Dn Sf Rg Cr Eb	1,60
VS-010	M6	17,4	7,9	8,4	17	Dn Sf Rg Cr Eb	2,30
VS-011	M5	15	7,4	7,5	12	Dn Sf Rg Cr Eb	2,30
VS-016	M8	24,5	9,9	5,5	15	Dn Sf Rg Cr Eb	2,30
VS-017	M6	12,5	10	4,2	15	Dn Sf Rg Cr Eb	2,30
VS-019	M8	33	9,9	11	15	Dn Sf Rg Cr Eb	2,30
VS-021	M4	21,5	4	5,5	10	Dn Sf Rg Cr Eb	1,30
VS-022	M4	7	/	/	10	Dn Sf Rg Cr Eb	1,15
VS-023	M6	20	8,3	9,5	18	Dn Sf Rg Cr Eb	1,15
VS-024	M6	12	/	/	8,5	Dn Sf Rg Cr Eb	2,30
VS-025	M6	11,5	8,2	3,75	14	Dn Sf Rg Cr Eb	2,30
VS-026	M6	15	7,9	6	14	Dn Sf Rg Cr Eb	2,30
VS-027	M6	15	8,9	4	14	Dn Sf Rg Cr Eb	2,30
VS-029	M6	15	9,9	3,5	17	Dn Sf Rg Cr Eb	2,30
VS-030	M6	15	9	2	14	Dn Sf Rg Cr Eb	2,30
VS-031	M6	14	7,9	5,5	14	Dn Sf Rg Cr Eb	2,30
VS-032	M6	21	8,25	13	17	Dn Sf Rg Cr Eb	2,30
VS-033	M6	25,5	8	10,5	24	Dn Sf Rg Cr Eb	2,30
VS-034	M6	19,7	9,9	8,7	17	Dn Sf Rg Cr Eb	2,30
VS-035	M6	11,9	7,9	3,9	16	Dn Sf Rg Cr Eb	2,30
VS-036	M6	18,3	7,8	7,8	15,6	Dn Sf Rg Cr Eb	2,30
VS-037	M6	13	6,9	4,4	14	Dn Sf Rg Cr Eb	2,30
VS-038	M6	15	7,9	6	17	Dn Sf Rg Cr Eb	2,30
VS-039	M6	11	9,9	3,5	17	Dn Sf Rg Cr Eb	2,30
VS-041	M6	14,5	11,9	3,5	17	Dn Sf Rg Cr Eb	2,30
VS-043	M6	19,5	7,5	3,5	14	Dn Sf Rg Cr Eb	2,30
VS-052	M6	15	7,9	3	14	Dn Sf Rg Cr Eb	2,30
VS-053	M6	15	9,85	5	22	Dn Sf Rg Cr Eb	2,30
VS-054	M6	19	7,9	8	14	Dn Sf Rg Cr Eb	2,30
VS-056	M6	14	7,9	3,8	14	Dn Sf Rg Cr Eb	2,30
VS-058	M6	16	8,4	3,5	14	Dn Sf Rg Cr Eb	2,30
VS-060	M5	10	8,9	3	14	Dn Sf Rg Cr Eb	2,30
VS-061	M6	15	8,9	5	14	Dn Sf Rg Cr Eb	2,30
VS-062	M5	15	7	2,5	11,5	Dn Sf Rg Cr Eb	2,30
VS-063	M5	20,5	7	13,5	12	Dn Sf Rg Cr Eb	2,30
VS-064	M5	20,5	6,9	2,5	12	Dn Sf Rg Cr Eb	2,30
VS-065	M6	11	8,2	4	14	Dn Sf Rg Cr Eb	2,30
VS-066	M6	15	9,8	5,5	22	Dn Sf Rg Cr Eb	2,30
VS-069	M6	25,5	8	13,5	17	Dn Sf Rg Cr Eb	2,30
VS-071	M6	21	10	8	17	Dn Sf Rg Cr Eb	2,30
VS-075	M6	16,5	8,2	5	12	Dn Sf Rg Cr Eb	2,30
VS-077	M5	17	8,2	5,8	14	Dn Sf Rg Cr Eb	2,30
VS-078	M6	20	8,7	9,2	14	Dn Sf Rg Cr Eb	2,30
VS-091	M5	8	7,9	2	13	Dn Sf Rg Cr Eb	2,30

M	Durchmesser Gewinde/Thread diameter
LG	Lange Schaft/Shank length
DC	Durchmesser Schaft/Cylinder diameter
LC	Länge Zylinder/Cylinder length
DT	Durchmesser Kopf/Head diameter

COOL STRIPES FELGENRANDAUFKLEBER WHEEL STICKERS

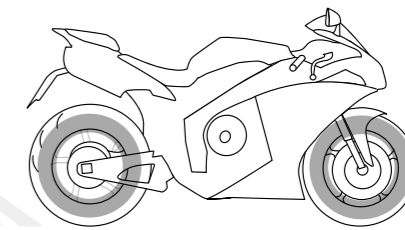

Selbstklebender Kit von Felgenrandaufklebern mit einem geformten Design. Felgenrandaufkleber sind passend für 14-17 Zoll Felgen. Verschiedene Designs verfügbar Streifen und Farbe für Ihr Motorrad... Evotech

Adhesive stripes kit preformed to personalize in a completely new way your motorbike's wheels! "Cool stripes" stickers for 14-17 rims. In order to take heed of the design this time Evotech not only gives you the common mono-color stripes but it also offers you a circle shaped sticker, which is therefore much easier to apply. The stripes have a coloured writing on a black background! Give color and style to your motorbike ... Evotech!



MARKE/BRAND	BESCHREIBUNG/DESCRIPTION	CODE/CODE	FARB/CODE/COLOUR	EURO w/o tax
EVOTECH	KIT FÜR 1 MOTORRAD / FOR ONE BIKE	STRIP-01 / Cr	ROT / RED	18,00
	KIT FÜR 1 MOTORRAD / FOR ONE BIKE	STRIP-01 / Eb	BLAU / BLUE	18,00
	KIT FÜR 1 MOTORRAD / FOR ONE BIKE	STRIP-01 / Wh	WEIß / WHITE	18,00
	KIT FÜR 1 MOTORRAD / FOR ONE BIKE	STRIP-01 / Gr	GRÜN / GREEN	18,00
	KIT FÜR 1 MOTORRAD / FOR ONE BIKE	STRIP-01 / Ye	GELB / YELLOW	18,00
	KIT FÜR 1 MOTORRAD / FOR ONE BIKE	STRIP-01 / Or	ORANGE / ORANGE	18,00



MARKE/BRAND	BESCHREIBUNG/DESCRIPTION	CODE/CODE	FARB/CODE/COLOUR	EURO w/o tax
T-MAX	KIT FÜR 1 MOTORRAD / FOR ONE BIKE	STRIP-02/Cr	ROT / RED	18,00
	KIT FÜR 1 MOTORRAD / FOR ONE BIKE	STRIP-02 / Eb	BLAU / BLUE	18,00
	KIT FÜR 1 MOTORRAD / FOR ONE BIKE	STRIP-02 / Wh	WEIß / WHITE	18,00
	KIT FÜR 1 MOTORRAD / FOR ONE BIKE	STRIP-02/ Ye	GELB / YELLOW	18,00

RACING ZUBEHÖR RACING ACCESSORIES

SCHNELLKUPPLUNG / QUICK FUEL COUPLING

Diese einfache, aber geniale Schnellkupplung ermöglicht es Ihnen den Tank schnell abzunehmen. Unverzichtbar bei Rennzwecken oder beim normalen Strasseneinsatz Ihres Motorrades/Minibikes. Durch das Drücken des Knopfes entkoppeln Sie die Kraftstoffkupplung. Die beiden Ventile verhindern das Auslaufen des Kraftstoff. In einem speziellen Kunststoff (ACETAL) gefertigt. Extrem leicht, stabil, Kohlenwasserstoffbeständigkeit, Druckbeständigkeit (83 bar)

This simple but brilliant accessory allows to quicken and makes easier and comfortable the removal of the tank. Indispensable on the races, very useful on every motorbike /mini bike, allows to tear out the fuel pipes by simply pressing of a button It has a double valve system which prevents the leak of gasoline. Realized in a special thermoplastic resin (Acetal) they are extremely light , heavy-duty, hydrocarbon-proof and resist even to high pressure (83 bar).



AVAILABLE FOR PETROL TUBES WITH 8mm AND 6,4mm DIAMETER

CODE/CODE	BESCHREIBUNG/DESCRIPTION	EURO w/o tax
EV-BSG	SCHNELLKUPPLUNG 8mm/8mm QUIK FUEL COUPLING	28,00
EV-BSP	SCHNELLKUPPLUNG 6,4mm/6,4mm QUICK FUEL COUPLING	32,00

FLÜSSIGKEITSBEHÄLTER / RECOVERING TANK

Flüssigkeitsbehälter für Wasser, Öl und Kraftstoffe. Dies ist die perfekte Lösung um den Originalbehälter zu ersetzen. Dieser Kit beinhaltet:

- semitransparente Plastikflasche mit speziellem Deckel (Einsatz eines Sicherungsdrahtes möglich)
- eine lasergeschnittener, gekanteter, eloxierter und mit dem Evotech-Logo gravierter Halterahmen
- ein O-Ring zur Fixierung des Flüssigkeitsbehälters im Halterahmen

Dieser Kit ist optimal geeignet für den Einsatz bei Supermotos, und Tourenmotorräder, als Zusatztank für Kraftstoffe, Öl und Wasser.

Recovering tank for water, oil and fuel vents. This is the perfect solution for replacing the original recovering tank. This kit includes:

- a semi-transparent plastic bottle with threaded caps (suitable for safety wire).
- one aluminum support laser cut, satinized, black anodized and laser branded.
- one o-ring to fix the bottle on the support

It is ideal also for Supermotard motorbikes where it can be used to recover the various gas, oil and water leaks.



PB-01	FLÜSSIGKEITSBEHÄLTER/RACING RECOVERING TANK 500 ml.	28,00
PB-02	FLÜSSIGKEITSBEHÄLTER/RACING RECOVERING TANK 250 ml.	25,00

RACING ZUBEHÖR RACING ACCESSORIES

SCHNELLVERSCHLÜSSE 1/4 TURN FAIRING FASTENERS

Sie ermöglichen die Montage und Demontage der Verkleidung ohne Werkzeug! (Pin, Teflon-Scheibe, Clip)

They enable you to assemble and disassemble the fairing and others boards without any tools! (1 ring head, 1 teflon spacer, 1 slip or rivet receptable)



CODE/CODE	DURCHMESSER x LÄNGE / DIAMETER	RECEPTABLE	EURO w/o tax
SG-12-SLIP	6 x 12mm	clip	5,00
SG-12-RIV	6 x 12mm	dreh-pin	5,00
SG-412-SLIP	4 x 12mm	clip	6,00
SG-412-RIV	4 x 12mm	dreh-pin	6,00
SG-17-SLIP	6 x 17mm	clip	5,00
SG-17-RIV	6 x 17mm	dreh-pin	5,00

CODE/CODE	BESCHREIBUNG / DESCRIPTION	EURO w/o tax
SG-12	PIN MIT RING/RING HEAD 6 x 12mm	3,50
SG-17	PIN MIT RING/RING HEAD 6 x 17mm	3,50
SGB-12	PIN OHNE RING/NO RING HEAD 6 x 12mm	3,50
SGB-17	PIN OHNE RING/NO RING HEAD 6 x 17mm	3,50
326-100-040	TEFLON SCHEIBE 6mm/TEFLON SPACER	0,20
336-300-190	CLIP RECEPTABLE 6mm/SLIP RECEPTABLE	2,30
336-400-190	DREH-PIN RECEPTABLE 6mm/RIVET RECEPTABLE	2,30
SG-412	PIN MIT RING//RING HEAD 4 x 12mm	3,80
324-100-040	TEFLON SCHEIBE 4mm/TEFLON SPACER	0,20
334-300-190	CLIP RECEPTABLE 4mm/SLIP RECEPTABLE	2,50
334-400-190	DREH-PIN RECEPTABLE 4mm/RIVET RECEPTABLE	2,50

EVOTECH

\ INNOVIAMO PER VOI \

Die fortschrittlichen Technologien von Evotech zeigen sich in vielen neuen und innovativen Projekten aus dem Bereich der NULL-Emissions Mobilität und der erneuerbaren Energie-Ressourcen. Diese fortschrittlichen Projekte entstehen in Zusammenarbeit mit verschiedenen Partnern, wie dem Fiat Forschungszentrum

The Evotech advanced technology is showed in many new and innovative projects concerning the zero-emissions mobility and the renewable energies resources. These advanced projects originate from the collaboration with various partners, such as the Fiat Center of Research.



Allgemeine Geschäftsbedingunge

General sales conditions

BESTELLUNGEN

Alle Bestellungen sind verbindlich, sobald die Produktion begonnen hat. Stornierungen oder Reduzierungen von Bestellungen sind nicht möglich, es sei denn, wenn der Kunde eine Entschädigung für Material- und Lohnkosten von EVOTECH übernimmt.

PREISE

Die Preise gelten ab dem Zeitpunkt der Bestellung. Steigen Material- und Lohnkosten während der Auftragsabwicklung und liegen die Gründe nicht im Einflussbereich von EVOTECH dann behält sich EVOTECH vor, die Preise zu überarbeiten. Sämtliche Katalogpreise enthalten keine Mehrwertsteuer.

LIEFERZEIT

Bestellungen werden von EVOTECH innerhalb von 15 Tagen versendet.

AUSLIEFERUNG

Die Waren werden ab Werk auf Gefahr des Käufers versandt. Der Käufer hat EVOTECH über seinen Spediteur zu informieren. Hat der Käufer keinen speziellen Spediteur, dann wird EVOTECH den Versand über dessen Spediteur vornehmen. Verpackungs- und Versandkosten gehen zu Lasten des Käufers

BEZAHLUNG

Die Bezahlung muss nach der vereinbarten Weise innerhalb des vereinbarten Zeitraums vorgenommen werden. Erfolgt ein Verzug bei der Bezahlung, behält sich Evotech vor, den gesamten Rechnungsbetrag vor Auslieferung einzufordern. Hierbei hat der Kunde kein Recht zur Forderung von Teillieferungen.

GEWÄHRLEISTUNG UND GARANTIE

Evotech übernimmt Gewährleistungsansprüche gegen jegliche Fabrikationsfehler bis zu 2 Jahren, beginnend ab dem Kaufdatum. Im Falle von fehlerhaften Produkten, die direkt bei Evotech gekauft wurden, empfehlen wir Ihnen, den sofortigen Kontakt mit uns aufzunehmen. Das defekte Produkt muß zur Prüfung an uns zurückgesendet werden. Zudem benötigen wir den Kaufbeleg und eine Beschreibung des Mangels.

Sie können Ihre Vertragserklärung innerhalb von einem Monat ohne Angabe von Gründen in Textform (z. B. Brief, Fax, E-Mail) oder - wenn Ihnen die Sache vor Fristablauf überlassen wird - durch Rücksendung der Sache widerrufen. Die Frist beginnt nach Erhalt dieser Belehrung in Textform, jedoch nicht vor Eingang der Ware beim Empfänger (bei der wiederkehrenden Lieferung gleichartiger Waren nicht vor Eingang der ersten Teillieferung) und auch nicht vor Erfüllung unserer Informationspflichten gemäß § 312c Abs. 2 BGB in Verbindung mit § 1 Abs. 1, 2 und 4 BGB-InfoV sowie unserer Pflichten gemäß § 312e Abs. 1 Satz 1 BGB in Verbindung mit § 3 BGB- InfoV. Zur Wahrung der Widerrufsfrist genügt die rechtzeitige Absendung des Widerrufs oder der Sache. Das Widerrufsrecht findet Anwendung bei Verträgen zwischen Privatleuten und

ORDERS

All orders are binding once production has started. Any cancellation or reduction of an order will not be accepted, unless the customer pays an indemnity for any material and labor costs incurred by Evotech.

PRICES

Prices are in force from the date of order. Prices are in force from the date of order. If material and labor costs increase during the supply of goods, due to causes beyond Evotech's control, Evotech will revise their prices. All prices in this catalogue don't include VAT.

DELIVERY TIME

Orders will be dispatched from Evotech in 15 working days.

DELIVERY

Goods are dispatched ex factory (at buyer's risk). The Buyer has to inform Evotech of his usual forwarding agent. If the customer does not have a particular forwarding agent then Evotech will deliver the goods through their own courier, all expenses will be charged to the customer. These charges will also include packing expenses.

PAYMENT

Payment must be made according to the agreed way and within the agreed time scale. If payment becomes overdue, Evotech has the right to stop the delivery and to claim a payment in advance without paying any compensation to the Buyer. Any objection about materials in progress or in the customer's hands does not relieve the customer of the due payment.

Evotech, nicht aber zwischen Evotech und einem anderen Unternehmen.

Der Widerruf ist zu richten an:

Evotech S.r.l. Via da Borgo, 14 38059 VILLA AGNEDO (TN) ITALY

Widerrufsfolgen

Im Falle eines wirksamen Widerrufs sind die beiderseits empfangenen Leistungen zurückzugewähren und ggf. gezogene Nutzungen (z. B. Zinsen) herauszugeben. Können Sie uns die empfangene Leistung ganz oder teilweise nicht oder nur in verschlechtertem Zustand zurückgewähren, müssen Sie uns insoweit ggf. Wertersatz leisten. Bei der Überlassung von Sachen gilt dies nicht, wenn die Verschlechterung der Sache ausschließlich auf deren Prüfung - wie sie Ihnen etwa im Ladengeschäft möglich gewesen wäre - zurückzuführen ist. Für eine durch die bestimmungsgemäße Ingebrauchnahme der Sache entstandene Verschlechterung müssen Sie keinen Wertersatz leisten.

Hello Gloria, the Widerrufsrecht has to be always written. If not, then it is possible for some lawyers, to charge you a penalty.

Paketversandfähige Sachen sind auf unsere Gefahr zurückzusenden. Sie haben die Kosten der Rücksendung zu tragen, wenn die gelieferte Ware der bestellten entspricht und wenn der Preis der zurückzusendenden Sache einen Betrag von 40 Euro nicht übersteigt oder wenn Sie bei einem höheren Preis der Sache zum Zeitpunkt des Widerrufs noch nicht die Gegenleistung oder eine vertraglich vereinbarte Teilzahlung erbracht haben. Anderenfalls ist die Rücksendung für Sie kostenfrei. Nicht paketversandfähige Sachen werden bei Ihnen abgeholt. Verpflichtungen zur Erstattung von Zahlungen müssen innerhalb von 30 Tagen erfüllt werden. Die Frist beginnt für Sie mit der Absendung Ihrer Widerrufserklärung oder der Sache, für uns mit deren Empfang.

EIGENTUMSVORBEHALT

Wir behalten uns das Eigentum an der Kaufsache bis zum Eingang der vollständigen Zahlung aus dem Vertrag vor.

DATENSCHUTZ

Evotech speichert und übermittelt die auftragsbezogenen persönlichen Daten des Kunden ausschließlich zur Bearbeitung und Abwicklung seiner Bestellung. Die Rechtsgrundlage hierfür bildet No.13, D.Lgs 30/60/2003 n.196. Änderungen seiner Kundendaten kann den Kunde ausschließlich schriftlich vornehmen.

GERICHTSSTAND

Sofern es sich bei dem Käufer um einen Kaufmann, eine juristische Person des öffentlichen Rechts handelt oder der Käufer keinen allgemeinen Gerichtsstand im Inland hat, ist der Gerichtsstand das Tribunal in Trento/Italien.

GÜLTIGKEIT

Dieser Katalog wurde am 1. Oktober 2010 gedruckt.

Termine und Preise sind gültig vom 1. Oktober 2010 bis auf weiteres.

WARRANTY

Evotech guarantees all goods against any manufacturing defects for up to 2 years, starting from the purchase date. In case of faulty items, which have been bought directly from Evotech, we recommend you contact Evotech immediately. The faulty product must be returned, at the Buyers costs, together with a proof of purchase and a written description of the defect. Returned items have to be authorized by Evotech by fax. Evotech has the right to analyze the returned items in order to check the cause of the damage. A guarantee will not be valid if items are damaged because of incorrect assembly and/or incorrect use. If the product has been purchased from a retailer, Evotech recommends you contact them directly advising them of the fault and including a proof of purchase.

OWNERSHIP

Evotech owns all dispatched goods until the invoice has been settled in full.

PRIVACY

Evotech will use the customer's details according to the article no.13, D.Lgs 30/60/2003 n.196. The data will be kept on written and digital files. The customer can modify his details at any time by written notification.

JURISDICTION

Any trade debate will be resolved by the Trento's tribunal.

VALIDITY

This catalogue was printed on 1st October 2010. Terms and prices are valid from 1st October 2010 until further notice.

Rechtlicher Hinweis

Evotech Srl hat keine Verbindung mit Aprilia®, BMW®, CAGIVA®, DUCATI®, Honda, Kawasaki®, MOTO GUZZI®, MV AGUSTA®, SUZUKI®, TRIUMPH®, YAMAHA® und / oder ihren Händlern. Alle Beschreibungen unserer Artikel mit den Markenamen und des Modells des Motorradherstellers sind lediglich zur Identifikation bestimmt. Referenz für den Einsatz in unserem Katalog und auf unserer Website www.evotech-rc.it sind nicht elektronisch, Vervielfältigt, kopiert oder sonst genutzt oder weitergegeben werden. Alle abgebildeten Warenzeichen, Logos, Produkt- und Firmennamen sind eingetragene Warenzeichen ihrer jeweiligen Eigentümer.

Evotech entwickelt und produziert kontinuierlich neue Produkte. Daher ist es unmöglich, alle Produkte in einen gültigen Katalog einzupflegen.

Aus diesem Grund empfehlen wir Ihnen regelmäßig unsere Website besuchen:

www.evotech-rc.it

Hier können Sie Anleitungen und Ratschläge für unsere Produkte zu finden.

Zudem gibt es auch zahlreiche Bilder unserer Produkte die an den jeweiligen Motorrädern verbaut sind.

Die Website zeigt auch Produkte und Anwendungen, die aus Platzgründen nicht in diesem Katalog dargestellt sind.

Evotech Srl has no connection with APRILIA®, BMW®, CAGIVA®, DUCATI®, HONDA, KAWASAKI®, MOTO GUZZI®, MV AGUSTA®, SUZUKI®, TRIUMPH®, YAMAHA® and/or their dealers. All items with trade mark names for motorcycles identification are to be intended only as a reference for the use in our catalogue and on our website www.evotech-rc.it

Evotech's production continually evolves, this makes it impossible to maintain an up to date catalogue. For this reason we recommend you regularly visit our web site:

www.evotech-rc.it

where you can find fitting instructions and advice for our products, there are also images of our products fitted to motorbikes. The web site will also show extra applications which are not in this catalogue due to space reasons.

Wenn Sie möchten, können Sie sich auf unserer Website für unseren Newsletter registrieren, So bleiben Sie über neue Produkte und spezielle Promotionen informiert.

If you wish, you can register on our website for our newsletter, this will keep you informed of new products and any special promotions.

Evotech S.r.l. lehnt jegliche Verantwortung für den Missbrauch von Evotech-Produkten ab.

Wir übernehmen keine Haftung für Schäden die aufgrund falscher Benutzung, bzw. fehlerhafter Installation entstanden sind.

Haftungsansprüche beschränken sich auf unsere Produkte, jedoch nicht auf Folgeschäden.

Produkte von Evotech, die nicht für den Strassenverkehr, bzw. die öffentliche Nutzung zugelassen sind dürfen vom Käufer für solche Zwecke nicht verwendet werden.

Einige Produkte sind nicht zulassungspflichtig und bei richtiger Anwendung im Strassenverkehr zugelassen.

Es obliegt dem Käufer die entsprechenden Rechtsvorschriften in diesem Bereich zu überprüfen und einzuhalten.

©2010 All rights reserved by Evotech S.r.l.

© 2010 Alle Rechte vorbehalten Evotech S.r.l.

EVOTECH PRODUZIERT FÜR/EVOTECH PRODUCES FOR



CENTRO
RICERCHE
FIAT



DUCATI
PERFORMANCE



EVOTECH S.p.A.

Via da Borgo, 14 - 38059 VILLA AGNEDO (TN)
Tel. +39 0461 780184 - Fax +39 0461 782707

www.evotech-rc.it / e-mail: info@evotech-rc.it
www.evotech-rc.de / email: info@evotech-rc.de